



an EnerSys® company

Cordex® CXC HP Controller Software Manual

User Guide ID: 0350058-J0

Effective: 01/2023



Read this document carefully.

Learn how to protect your equipment from damage and fully understand its functions.



NOTICE

For the latest version of software, firmware, and product documentation, visit the Alpha® website, www.alpha.com or www.alpha.ca.



NOTICE

Photographs contained in this document are for illustrative purposes only. These photographs may not match your installation.



NOTICE

Operator is cautioned to review the drawings and illustrations contained in this document before proceeding. If there are questions regarding the safe operation of this powering system, contact Alpha Technologies Ltd. or your nearest Cordex® power system representative.



NOTICE

Alpha Technologies Ltd. shall not be held liable for any damage or injury involving its enclosures, power supplies, generators, batteries, or other hardware if used or operated in any manner or subject to any condition inconsistent with its intended purpose, or if installed or operated in an unapproved manner, or improperly maintained.

Copyright notice

© 2023 Alpha Technologies Ltd., an EnerSys company. All Rights Reserved. Trademarks and logos are the property of EnerSys and its affiliates. Subject to revisions without prior notice. E.&O.E.

No part of this documentation shall be reproduced, stored in a retrieval system, translated, transcribed, or transmitted in any form or by any means manual, electric, electronic, electromechanical, chemical, optical, or otherwise without prior explicit written permission from Alpha Technologies Ltd.

This document, the software it describes, and the information and know-how they contain constitute the proprietary, confidential and valuable trade secret information of Alpha, and may not be used for any unauthorized purpose, or disclosed to others without the prior written permission of Alpha.

The material contained in this document is for information only and is subject to change without notice. While reasonable efforts have been made in the preparation of this document to assure its accuracy, Alpha assumes no liability resulting from errors or omissions in this document, or from the use of the information contained herein. Alpha reserves the right to make changes in the product design without reservation and without notification to its users.

Contents

List of Figures.....	14
List of Tables.....	16
1. Safety.....	17
2. Software release history.....	20
2.1. Application release 8.00.....	20
2.2. Application release 7.40.....	20
2.3. Application release 7.30.....	21
2.4. Application release 7.20.....	21
2.5. Application release 7.10.....	22
2.6. Application release 7.01.....	22
2.7. Application release 7.00.....	22
2.8. Application release 6.30.....	23
2.9. Application release 6.20.....	23
2.10. Application release 6.10.....	23
2.11. Application release 6.00.....	24
2.12. Application release 5.20.....	24
2.13. Application release 5.10.....	25
2.14. Application release 5.01.....	25
2.15. Application release 5.00.....	26
2.16. OS release 6.30.....	26
2.17. OS release 6.20.....	26
2.18. OS release 6.00.....	26
2.19. OS release 5.20.....	27
2.20. OS release 4.70.....	27
2.21. OS release 2.20.....	27
2.22. Known issues.....	27
3. Introduction.....	31
3.1. Using the Cordex® CXC HP Controller Software Manual.....	31
3.1.1. Purpose and audience.....	31
3.1.2. Knowledge and permissions.....	31
3.2. Product overview.....	31
3.2.1. What does the Cordex® CXC HP controller do?.....	32

- 3.2.2. Watchdog alarm..... 33
- 3.2.3. Typical system configuration..... 33
- 3.2.4. How to get help..... 34
- 4. Getting started..... 36**
 - 4.1. Apply power..... 36
 - 4.2. Connect to the controller..... 36
 - 4.2.1. In-shelf controller..... 38
 - 4.3. Navigating the controller user interface..... 38
 - 4.3.1. Log into the controller..... 38
 - 4.3.2. Controller menu..... 39
 - 4.3.3. Overview of the LCD..... 40
 - 4.3.4. Overview of the web interface..... 49
 - 4.3.5. Overview of the in-shelf display..... 58
 - 4.4. Email notification..... 59
 - 4.5. Setup SNMP communication..... 62
 - 4.6. Setting up Modbus communication..... 63
 - 4.7. Setup syslog communication..... 64
 - 4.7.1. Syslog agent configuration..... 64
 - 4.7.2. Syslog destination configuration..... 64
 - 4.7.3. Syslog message format..... 64
- 5. DC power systems..... 66**
 - 5.1. Guidelines for commissioning the DC system..... 66
 - 5.1.1. The battery mode..... 67
 - 5.2. DC system functions..... 67
 - 5.2.1. Modules, inventory, and system functions..... 67
 - 5.2.2. Mixed rectifier system..... 69
 - 5.2.3. Battery charging..... 69
 - 5.2.4. Battery temperature compensation..... 70
 - 5.2.5. Battery runtime and health estimation..... 71
 - 5.2.6. Low voltage disconnect operation..... 72
 - 5.2.7. Battery test..... 74
 - 5.2.8. Power save..... 76
 - 5.3. Create a DC system manually..... 78
 - 5.3.1. Quick reference for configuring a DC system..... 79

5.3.2. Create a DC system.....	81
5.3.3. Configure basic DC system settings.....	82
5.3.4. Configure dynamic thresholds for output voltage alarms.....	82
5.3.5. Configure the rectifiers.....	82
5.3.6. Configure the shunts.....	83
5.3.7. Configure the system loads.....	84
5.3.8. Configure the current transducer.....	85
5.3.9. Configure the general purpose transducer.....	85
5.3.10. Configure the system disconnects.....	86
5.3.11. Configure lead acid or NiCad battery parameters.....	87
5.3.12. Configure Polarium battery parameters.....	90
5.3.13. Configure the battery temperature sensors.....	91
5.3.14. Configure the charging system function.....	92
5.3.15. Configure the temperature compensation system function.....	93
5.3.16. Configure battery runtime and health estimation.....	94
5.3.17. Run a manual battery test.....	94
5.3.18. Configure power save.....	95
5.4. Connect to other systems.....	95
5.4.1. Represent a converter system as a DC load.....	96
5.4.2. Represent an inverter system as a DC load.....	96
6. Converter systems.....	98
6.1. Introduction to converter systems.....	98
6.2. Creating a converter system.....	99
6.2.1. Creating a system from a configuration file.....	100
6.3. Configure the converters.....	100
6.4. Configure the shunts.....	100
6.5. Configure the loads.....	101
6.6. Configure the current transducer.....	102
6.7. Configure the general purpose transducer.....	102
7. Inverter systems.....	104
7.1. Introduction to inverter systems.....	104
7.1.1. Components of a T2S inverter system.....	104
7.1.2. Quick reference for configuring an inverter system.....	105
7.1.3. Phase and group data.....	106

- 7.1.4. Live alerts..... 106
- 7.1.5. System functions..... 106
- 7.2. Create an inverter system..... 107
 - 7.2.1. Create a system from a configuration file..... 107
- 7.3. Assign a T2S module..... 108
- 7.4. Commission an inverter system..... 108
- 7.5. Configure the T2S inverter controller..... 110
- 7.6. Configure the inverters..... 110
- 7.7. Configure the bypass switch..... 110
 - 7.7.1. Configure a basic bypass switch..... 111
 - 7.7.2. Configure an XMBS bypass switch..... 111
- 7.8. Configure the breaker or fuse..... 112
- 8. Line power systems..... 113**
 - 8.1. Introduction to line power systems..... 113
 - 8.1.1. Components of a line power system..... 113
 - 8.1.2. Quick reference for configuring a line power system..... 115
 - 8.2. Create a line power system..... 115
 - 8.2.1. Create a system from a configuration file..... 116
 - 8.3. Configure the line power modules..... 116
 - 8.3.1. Shared alarm configuration..... 116
 - 8.4. Line power module alarms..... 117
 - 8.5. Configure the line power system channels..... 117
 - 8.6. Configure the line power system loads..... 117
 - 8.7. Line power system layout..... 118
 - 8.7.1. Use the layout screen to view module status..... 118
 - 8.7.2. Use the layout screen to view load status..... 119
 - 8.7.3. Use the layout screen to assign channels to loads..... 119
 - 8.8. Line power channels import..... 120
 - 8.8.1. Export line power channels..... 121
 - 8.8.2. Sort exported line power channels..... 121
 - 8.8.3. Enter data into a line power channels file..... 121
 - 8.8.4. Import a line power channels file..... 123
 - 8.8.5. Verify a line power channel import..... 123
- 9. Auxiliary systems..... 125**

9.1. Introduction to auxiliary systems.....	125
9.2. Create an auxiliary system.....	125
9.2.1. Create a system from a configuration file.....	125
9.3. Current transducers.....	125
9.4. Configure the current transducer.....	125
9.5. Configure the general purpose transducer.....	126
10. Distribution systems.....	127
10.1. Introduction to distribution systems.....	127
10.2. Create a distribution system.....	128
10.2.1. Create a system from a configuration file.....	128
10.3. Distribution subsystems.....	128
10.4. Create a smart subsystem.....	129
10.5. Create a user defined subsystem.....	130
10.6. Configure the panel details.....	131
10.7. Configure the breaker or fuse details.....	132
10.8. The subsystem layout.....	133
10.9. Map shunts to ADIO module inputs.....	133
11. DC source systems.....	135
11.1. Create a DC source system.....	135
11.2. Create and configure a DC source.....	135
11.3. DC source system effect on other systems.....	136
12. AC source systems.....	137
12.1. Create an AC source system.....	137
12.2. Create an AC source.....	137
12.2.1. Map rectifiers to an AC source.....	138
13. Cordex® CXPS-HSS Hyperboost converter system.....	140
13.1. Introduction to CXPS-HSS Hyperboost systems.....	140
13.2. Creating a CXPS-HSS Hyperboost system.....	140
13.3. Configure the CXPS-HSS Hyperboost converters.....	141
13.4. Configure the shunts.....	141
13.5. Configure the loads.....	142
13.6. Configure the current transducer.....	143
13.7. Configure the general purpose transducer.....	143
13.8. Matrix C16™ high density connectorized DC distribution breaker panel.....	143

- 13.8.1. Introduction to Matrix C16™ high density connectorized DC distribution breaker panel..... 144
- 13.8.2. Matrix C16™ high density connectorized DC distribution breaker panel in a CXPS-HSS Hyperboost system..... 144
- 14. Generator..... 145**
 - 14.1. Create an AC generator..... 145
 - 14.2. Create a DC generator..... 146
 - 14.3. Configure the generator..... 146
 - 14.4. Start and stop conditions..... 147
 - 14.4.1. Default start and stop conditions..... 147
 - 14.4.2. Add start and stop conditions..... 147
 - 14.4.3. Adding complex start and stop conditions..... 148
 - 14.4.4. Testing start and stop conditions..... 148
 - 14.4.5. Example: Start and stop the generator on a schedule..... 148
 - 14.5. Start and stop logic..... 149
 - 14.5.1. Start logic..... 150
 - 14.5.2. Stop logic..... 150
 - 14.6. Generator state..... 151
 - 14.7. Alarms..... 152
 - 14.8. Legacy generator..... 153
 - 14.8.1. Create a legacy AC generator..... 153
 - 14.8.2. Create a legacy DC generator..... 154
 - 14.8.3. Configure legacy generator control..... 154
 - 14.8.4. Configure legacy generator alarms..... 155
- 15. FXM HP UPS systems..... 156**
- 16. Thermal systems..... 157**
 - 16.1. Introduction..... 157
 - 16.2. Create a thermal system..... 157
 - 16.3. Thermal system configurations..... 157
 - 16.3.1. Single-cabinet setup..... 157
 - 16.3.2. Multi-cabinet setup..... 157
 - 16.4. Logging temperatures..... 158
 - 16.5. Logging filter replacement date..... 158
 - 16.6. Logging fan replacement dates..... 159

16.7. Alarms and alerts.....	159
16.7.1. Thermal controller module alert to thermal system alarm propagation.....	159
16.7.2. Identifying the origin of an active alarm.....	159
16.7.3. Alarms where hardware does not exist.....	160
17. Controller redundancy.....	161
18. Power flow.....	162
18.1. Introduction to power flow.....	162
18.2. Access power flow.....	162
18.2.1. Getting help.....	162
18.2.2. Use power flow configuration suggestions.....	163
18.2.3. Configure the default power flow.....	163
18.3. Interact with power flow.....	163
18.4. Controller power flow.....	164
18.5. Power flow for systems managed by different controllers.....	165
19. Maintaining the system.....	167
19.1. Rectifier maintenance.....	167
19.1.1. Rectifier alarms.....	167
19.1.2. Insert unassigned modules.....	167
19.2. Inverter and T2S system maintenance.....	167
19.2.1. Maintenance bypass.....	168
19.2.2. Taking power from DC source.....	168
19.2.3. Replace the fan.....	169
19.2.4. Identify an inverter.....	169
19.2.5. Alarms and alerts.....	170
19.2.6. Replace a T2S inverter system.....	170
19.2.7. Shelf layout.....	171
19.3. Line power system maintenance.....	171
19.3.1. Power off and on line power loads.....	171
19.3.2. Replace line power modules.....	171
19.4. Battery maintenance.....	172
19.4.1. Battery alarms.....	172
19.4.2. Charging batteries.....	173
19.4.3. Maintaining batteries.....	174
19.4.4. Battery temperature compensation.....	177

- 19.5. Low voltage disconnect (LVD) maintenance..... 177
- 20. Maintaining the controller..... 179**
 - 20.1. Ethernet communications..... 179
 - 20.1.1. Connect via the web interface..... 180
 - 20.2. Working with alarms, alerts, and hints..... 180
 - 20.2.1. Active alarms..... 180
 - 20.2.2. Alerts..... 181
 - 20.2.3. Hints..... 181
 - 20.2.4. Alarm cut-off (ALCO)..... 182
 - 20.2.5. Alarm activation delay at startup..... 182
 - 20.2.6. Alarm summary relays..... 183
 - 20.2.7. Create user alarms..... 183
 - 20.3. Controller maintenance..... 184
 - 20.3.1. Restart the controller..... 184
 - 20.3.2. Restart the controller via the LCD..... 185
 - 20.3.3. Powering down the controller..... 185
 - 20.3.4. Change the time and date..... 186
 - 20.3.5. Change the language for the LCD..... 186
 - 20.3.6. Change the language for the web interface..... 186
 - 20.3.7. Change user interface strings..... 187
 - 20.3.8. Change the web session language..... 188
 - 20.3.9. Change the system status bar..... 188
 - 20.3.10. Change the dashboard values..... 189
 - 20.3.11. Data sharing..... 189
 - 20.3.12. Maintenance mode..... 190
 - 20.4. Working with logs..... 191
 - 20.4.1. Event and alert logs..... 192
 - 20.4.2. Battery log..... 193
 - 20.4.3. Power outage log..... 193
 - 20.4.4. Datalogs..... 194
 - 20.4.5. Performance logs..... 196
 - 20.5. File maintenance..... 197
 - 20.5.1. File preferences..... 197
 - 20.5.2. File maintenance from the LCD..... 197

20.5.3. Upgrade the controller software.....	199
20.5.4. Export a configuration file.....	200
20.5.5. Import a configuration file.....	201
20.5.6. Configuration restore points.....	204
20.5.7. Export diagnostic information.....	205
20.5.8. License key.....	206
20.5.9. Upload the software manual.....	207
20.5.10. Export inventory file.....	208
20.5.11. Backup and restore.....	209
20.6. User account maintenance.....	210
20.6.1. Set up users and permissions.....	210
20.6.2. Edit user permissions.....	210
20.6.3. Enable new users.....	211
20.6.4. Disable users.....	211
20.6.5. Changing the default password from the LCD.....	212
20.6.6. Changing the default password from the web interface.....	212
20.6.7. User account password requirements.....	212
20.6.8. Machine user.....	213
20.6.9. Remote configuration lockout.....	213
20.7. Remote authentication.....	214
20.7.1. RADIUS authentication.....	215
20.7.2. TACACS+ authentication.....	216
20.8. Flash maintenance.....	218
20.8.1. Memory status.....	218
20.8.2. Flash refresh.....	218
20.9. Secure web server.....	218
20.9.1. HTTPS and certificate overview.....	218
20.9.2. Configure HTTPS.....	219
20.10. VLAN support.....	221
20.11. Test relays.....	221
21. Maintaining modules.....	223
21.1. ADIO peripheral maintenance.....	223
21.1.1. Configure an ADIO peripheral.....	223
21.1.2. Replace an ADIO peripheral.....	223

- 21.1.3. Calibrate analog inputs..... 224
- 21.1.4. Calibrate shunts, current transducers, and temperature probes.....228
- 21.1.5. Test relays..... 230
- 21.1.6. Test comms lost action..... 230
- 21.1.7. Enable temperature sensor failure alarms..... 230
- 21.1.8. Ground fault detection.....231
- 21.2. Module firmware upgrades..... 231
 - 21.2.1. Module firmware upgrade..... 231
 - 21.2.2. Upload a firmware file..... 231
 - 21.2.3. Select the file to upgrade..... 232
 - 21.2.4. Upgrade the module..... 232
- 22. Using custom views, data, timers, counters, scheduler, and custom actions..... 234**
 - 22.1. Custom views..... 234
 - 22.1.1. Create custom views..... 234
 - 22.1.2. Add components in the custom view..... 234
 - 22.1.3. Access and configure the default custom dashboard view..... 236
 - 22.1.4. Access the custom data view..... 236
 - 22.1.5. Remove a table from the custom view..... 236
 - 22.1.6. Add an existing table to the custom view..... 237
 - 22.2. Custom data..... 237
 - 22.2.1. Configure custom data..... 237
 - 22.2.2. Create custom data..... 242
 - 22.2.3. Create custom data - basic work flow..... 243
 - 22.2.4. Create custom data - detailed work flow..... 243
 - 22.2.5. Custom data examples..... 244
 - 22.2.6. Custom data - summing load shunts..... 244
 - 22.2.7. Custom data - AC cooling too low user alarm..... 244
 - 22.3. Using timers..... 244
 - 22.3.1. Configure the delay timer..... 245
 - 22.3.2. Configure the interval timer..... 246
 - 22.4. Counters..... 247
 - 22.4.1. Configure the up counter..... 247
 - 22.4.2. Configure the down counter..... 248
 - 22.5. Scheduler..... 249

22.5.1. Configure a recurring action.....	250
22.6. Configure a one-time action.....	250
22.7. Configure scheduled actions.....	250
22.8. Scheduled time spans.....	251
22.9. Custom actions.....	251
22.9.1. Configure a change relay action.....	251
22.9.2. Configure a change field to constant action.....	252
22.9.3. Configure a change field to variable action.....	253
23. Troubleshooting.....	255
23.1. Troubleshoot the controller.....	255
23.1.1. No communication.....	255
23.1.2. Unable to communicate via ethernet.....	255
23.1.3. Home button or LCD screen not responding.....	256
23.1.4. Controller fail.....	256
23.2. Troubleshoot a rectifier system.....	257
23.2.1. Relays not triggered during alarm conditions.....	257
23.2.2. Rectifier alarms and alerts.....	257
23.2.3. Rectifier not acquired.....	258
23.2.4. Rectifier communication lost.....	258
23.2.5. Replacing a defective rectifier.....	258
23.2.6. Using extended ranges.....	259
23.2.7. Rectifier configuration error.....	260
23.2.8. Rediscovering CAN devices.....	260
23.2.9. Replacing a defective ADIO peripheral.....	260
23.2.10. Troubleshoot a battery test.....	260
23.2.11. Troubleshoot power save.....	261
23.3. Troubleshoot an inverter system.....	262
23.3.1. Wrong inverter AC input group.....	263
23.3.2. Wrong inverter DC input group.....	263
23.3.3. T2S expert operations.....	263
23.3.4. Troubleshoot and clear the system error alarm.....	264
23.3.5. Phase saturation alarm.....	264
23.4. Troubleshooting a line power system.....	265
23.4.1. Resolving line power system alarms.....	265

- 23.4.2. Fan tray alarms.....265
- 23.4.3. Line power system overload.....266
- 23.4.4. Line power system transient events.....266
- 23.4.5. Line power channels file import errors.....266
- 24. Cordex® CXC HP controller reference guide.....269**
 - 24.1. CAN modules.....269
 - 24.2. Communication ports.....271
 - 24.2.1. Ethernet ports.....271
 - 24.2.2. USB ports.....271
 - 24.2.3. CAN ports.....272
 - 24.3. Default system values and ranges.....273
 - 24.3.1. 12 volt system default values and ranges.....273
 - 24.3.2. 24 volt system default values and ranges.....274
 - 24.3.3. 48 volt system default values and ranges.....275
 - 24.3.4. 125 volt system default values and ranges.....276
 - 24.3.5. 220 volt system default values and ranges.....277
- 25. Index.....**

List of Figures

Figure 3-1 Cordex® CXC HP controller (2RU model).....	32
Figure 3-2 Typical DC system configuration.....	34
Figure 3-3 Accessing Help on the LCD interface.....	34
Figure 3-4 Accessing Help on the web interface.....	35
Figure 3-5 Accounts and shortcuts	35
Figure 4-1 Menu structure.....	40
Figure 4-2 Controller LCD dashboard	41
Figure 4-3 Maintenance page	42
Figure 4-4 System maintenance page	42
Figure 4-5 LCD menus page.....	43
Figure 4-6 Controller status page.....	44
Figure 4-7 Time and date page.....	44
Figure 4-8 Time zone page.....	45
Figure 4-9 Network time server page.....	45
Figure 4-10 Synchronize time	46
Figure 4-11 Shortcuts.....	46
Figure 4-12 Ethernet page.....	46
Figure 4-13 Inventory summary page.....	47
Figure 4-14 Dashboard with multi-system panels.....	47
Figure 4-15 Dashboard using wide data panel view.....	48
Figure 4-16 Export diagnostic information.....	48
Figure 4-17 Backup.....	49
Figure 4-18 Dashboard overview on web interface.....	50
Figure 4-19 Global search example.....	51
Figure 4-20 Web interface table features.....	52
Figure 4-21 Alarms menu.....	55
Figure 4-22 Logs menu.....	56
Figure 4-23 Shelf layout menu.....	57
Figure 4-24 SMTP client and server default ports.....	60
Figure 4-25 SNMP manager and agent default ports.....	62
Figure 4-26 Default ports: Modbus client (master) and server (agent).....	63
Figure 5-1 Three-stage charging cycle.....	69

Figure 5-2 Temperature compensation voltage graph..... 71

Figure 5-3 Example of a DC system..... 78

Figure 5-4 Quick reference for configuring a DC system..... 80

Figure 6-1 Example converter system..... 98

Figure 6-2 Quick reference for configuring a converter system.....99

Figure 7-1 Single T2S inverter system components 104

Figure 7-2 Quick reference for configuring an inverter system 105

Figure 7-3 A fully configured XMBS bypass switch with hardwired I/O signals..... 112

Figure 7-4 A fully configured XMBS bypass switch with CAN signals..... 112

Figure 8-1 Example Cordex® HP LPS36 line power system..... 114

Figure 8-2 Example Cordex® HP eLimiter+ class 2 distribution system..... 114

Figure 8-3 Quick reference for configuring a line power system 115

Figure 8-4 A non-filled sorted line power channels CSV file..... 122

Figure 10-1 Example of a DC system distribution system..... 127

Figure 10-2 Example of BDFB distribution subsystem..... 130

Figure 10-3 Example of a user defined subsystem..... 131

Figure 13-1 Example CXPS-HSS Hyperboost system..... 140

Figure 14-1 Generator state flowchart..... 151

Figure 18-1 Power flow for a DC system..... 162

Figure 18-2 Power flow configuration suggestions..... 163

Figure 18-3 Interacting with power flow..... 164

Figure 18-4 Controller power flow..... 165

Figure 18-5 Using data sharing to create power flow across different controllers..... 165

Figure 19-1 Battery maintenance system functions..... 174

Figure 20-1 Events Log..... 192

Figure 20-2 Battery log on the web interface..... 193

Figure 20-3 Battery log in Excel..... 193

Figure 20-4 Example certificate..... 220

Figure 20-5 Valid certificate..... 220

Figure 22-1 Text mapping for a custom data representing air conditioning states..... 242

Figure 24-1 CAN differential signaling..... 272

Figure 24-2 CAN network topology..... 273

Figure 24-3 Alpha® CAN connector..... 273

List of Tables

Table 4-1 In-shelf controller full menu.....	59
Table 4-2 Email notification features.....	60
Table 4-3 Email configuration.....	62
Table 4-4 Controller alarm priorities to Syslog severities mapping table.....	65
Table 14-1 Default start and stop conditions when a DC system and battery are present.....	147
Table 14-2 Default start and stop conditions when a DC system is present without a battery.....	147
Table 21-1 ADIO input calibration modes.....	224
Table 23-1 Troubleshooting power save.....	261
Table 23-2 Example of an event entry for error (time column not displayed):.....	267
Table 23-3 Troubleshooting errors in a line power channels CSV file.....	267
Table 24-1 Support for CAN modules.....	269
Table 24-2 12 volt system default values and ranges.....	274
Table 24-3 24 volt system default values and ranges.....	274
Table 24-4 48 volt system default values and ranges.....	275
Table 24-5 125 volt system default values and ranges.....	276
Table 24-6 220 volt system default values and ranges.....	277

1. Safety

SAVE THESE INSTRUCTIONS: This document contains important safety instructions that must be followed during the installation, servicing, and maintenance of the product. Keep it in a safe place. Review the drawings and illustrations contained in this document before proceeding. If there are any questions regarding the safe installation or operation of this product, contact Alpha Technologies Ltd. or the nearest Alpha® power system representative.

Safety wording and symbols

To reduce the risk of injury or death, and to ensure the continued safe operation of this product, the following symbols have been placed throughout this document. Where these symbols appear, use extra care and attention.

 **Attention:** *The use of attention indicates specific regulatory or code requirements that may affect the placement of equipment or installation procedures.*

 **Notice:** *Notices provide additional information to help complete a specific task or procedure.*

 **Important:** *Follow the prescribed procedures to avoid equipment damage or service interruption.*

 **CAUTION:** *Cautions indicate safety information intended to PREVENT DAMAGE to material or equipment.*

 **Warning:** *Warnings present safety information to PREVENT INJURY OR DEATH to personnel.*

 **CAUTION:** *HOT! The use of Hot presents safety information to PREVENT BURNS to the technician or user*

General warning and cautions

 **Warning:** *You must read and understand the following warnings before installing the system and its components. Failure to do so could result in personal injury or death.*

- Read and follow all instructions included in this manual.
- Only trained personnel are qualified to install or replace this equipment and its components.
- Use proper lifting techniques whenever handling equipment, parts, or batteries.

Electrical safety

 **Warning:** Hazardous voltages are present at the input of power systems. The DC output from some rectifiers and batteries can have high voltage and high short-circuit current capacity that may cause severe burns and electrical arcing.

Before working with any live battery or power system, follow these precautions:

- Remove all metallic jewelry, such as watches, rings, metal rimmed glasses, or necklaces.
- Wear safety glasses with side shields at all times during the installation.
- Use OSHA approved insulated hand tools. Do not rest tools on top of batteries.

 **Warning:** Lethal voltages are present within the power system. Always assume that an electrical connection or conductor is energized. Check the circuit with a voltmeter with respect to the grounded portion of the enclosure (both AC and DC) before performing any installation or removal procedure.

- Do not work alone under hazardous conditions.
- A licensed electrician is required to install permanently wired equipment. Input voltages can range up to 480 Vac. Ensure that the utility power is disconnected and locked out before performing any installation or removal procedure.
- Ensure that no liquids or wet clothes come into contact with internal components.
- Hazardous electrically live parts inside this unit are energized from the batteries even when the AC input power is disconnected.
- The enclosure which contains the DC or AC power system along with customer installed radios must remain locked at all times, except when authorized service personnel are present.
- Always assume electrical connections or conductors are live. Turn off all circuit breakers and double-check with a voltmeter before performing installation or maintenance.
- Place a warning label on the utility panel to warn emergency personnel that a reserve battery source is present which will power the loads in a power outage condition or if the AC disconnect breaker is turned off.
- At high ambient temperature conditions, the internal temperature can be hot so use caution when touching the equipment.

Battery safety

- Never transport an enclosure with batteries installed. Batteries must only be installed after the enclosure has been securely set in place at its permanent installation location. Transporting the unit with batteries installed may cause a short circuit, fire, explosion, or damage to the battery pack, enclosure, and installed equipment.
- Servicing and connection of batteries must be performed by, or under the direct supervision of, personnel knowledgeable of batteries and the required safety precautions.
- Batteries contain or emit chemicals known to cause cancer and birth defects or other reproductive harm. Battery post terminals and related accessories contain lead and lead compounds. Wash your hands after handling batteries.



Warning: *Follow battery manufacturer's safety recommendations when working around battery systems. Do not smoke or introduce an open flame when batteries (especially vented batteries) are charging. When charging, batteries vent hydrogen gas, which can explode.*

- Batteries are hazardous to the environment and should be disposed at a recycling facility. Consult the battery manufacturer for recommended local authorized recyclers.

2. Software release history

The release history for recent versions are found in the following sections. For a full release history visit the Alpha® website at **Support > Software/Firmware Downloads**.



Notice: *Reverting the Cordex® CXC HP or FXM HP controller to earlier versions of the operating system is not advisable, and can cause unpredictable results, including failure to boot.*

2.1. Application release 8.00

Released: January 2023

Contains the following significant changes:

- New user interface look and feel. Improved navigation scheme.
- Added Syslog messaging support (UDP Only) for up to 10 destinations.
- Added support for Cordex® CXPS-HSS Hyperboost converter system and modules
- Added support for the Matrix C16™ high density connectorized DC distribution breaker panel
- Updated Load Shunt Pair CSV for better readability and configuration input.
- In miller column selection, moved No Source configuration field to be right after Unknown. Previously, was situated under the Controller menu.
- Changed module locate functionality to continue to flash the module LEDs for up to five minutes (approximately).
- Fixed an issue for Modbus Limited Dataset where the battery mode was not properly updated.
- Updated drag and drop functionality for manually configured shelf layout systems.
- Added FXM HP Battery Temperature to performance logs.
- Removed Module Assignment Rule for systems from the web user interface. The assignment rule is now set to always automatic on new system creation.
- Fixed AMPS HP2 Phase 2 Output Watts calculation.

2.2. Application release 7.40

Released: September 2022

Contains the following significant changes:

- Added a Maintenance Mode feature, which inhibits alarm summary relays during maintenance.
- Added a Custom Data Result as Text feature, which displays custom data equation results as text, in addition to the already existing Result as Numeric and Result as Boolean.
- Added LCD dashboard text size and alignment options in the user interface preferences.

- Added an additional authentication attribute for RADIUS remote authentication.
- Added Preliminary Polarium battery support for the DC System. Initial support monitors the batteries only.
 - Feature compatibility is not guaranteed in future software releases.
 - Power Flow is not available for the Polarium battery.
 - The Polarium Protocol Bridge will send meaningless values when no battery modules are connected. These can safely be ignored.

2.3. Application release 7.30

Released: July 2022

Contains the following significant changes:

- Improved support for NiCad batteries.
- Changed the maximum value of the FXM HP UPS Keep Alive Startup Delay to 3600 seconds.
- Added an option to turn the FXM HP UPS on automatically after programmed AC Output Shutdown.
- Added the ability to shutdown the FXM HP UPS AC output voltage via SNMP in the UPS MIB.
- Changed the way invalid values are indicated in SNMP.
- Fixed a problem with the reporting of upsEstimatedMinRemaining value in the UPS MIB.
- Added missing ControllerInfo fields in the Resource MIB.
- The Battery Current Source field, for a battery system, has had available mapping options reduced. Any load related options and the Total Output Current field are no longer available for mapping.
- On upgrade to version 7.30 from any prior version of Cordex® CXC HP software, if a DC System Battery String had mapped its Battery Current Source to Total Output Current then it will be set to "---" on upgrade. Manual intervention is required to update the source to either a battery shunt or a calculation. This fixes a potential problem with unintended battery discharge due to incorrect battery current configuration.
- A suffix has been added to the name exported config files to distinguish between clone, system/ADIO, and partial.
- Total Output Current field for a DC System has been renamed to Total Rectifier O/P Current.
- On a Change Relay action, the Relay To Change entry no longer requires an exclusive relay; the chosen relay can now be shared with other alarms.

2.4. Application release 7.20

Released: January 2022

Contains the following significant changes:

- Improved Export Partial to allow partial configuration from multiple systems to be exported into one single file.
- Detached SNMPv3 credentials from the admin credentials to allow a unique username and password for SNMPv3.
- Added IPv6 support to Email, Network Time Server, Remote Authentication, Modbus, and Data Sharing.
- Fixed an issue when using an in-shelf controller (for example, Cordex® CXCM1 HP controller), where the backup, restore, and application upgrade features via a plugged in USB drive would not succeed.

2.5. Application release 7.10

Released: August 2021

Contains the following significant changes:

- Improved LPS system commissioning with added configuration import.
- New off-grid generator control.
- Improved event log for threshold alarm entries, showing value when alarm activated.
- Deprecated redundant DC System fields. These deprecated fields can be found in the battery string instead. See the version 7.10 Software Release Note for more information.

2.6. Application release 7.01

Released: March 2021

Contains the following significant changes:

- Added Heating and Cooling states for FlexAir® Thermal Controller.
- Added support for FlexAir® Relays states.
- Added support for XMBS G2 external maintenance bypass switch.

2.7. Application release 7.00

Released: December 2020

Contains the following significant changes:

- Support for Thermal System.
- Support for Battery Disconnect with latching contactor.
- Added a feature to export controller backups from the web interface.
- Improved voltage regulation to reduce small voltage fluctuations on some systems.

2.8. Application release 6.30

Released: August 2020

Contains the following significant changes:

- Added a feature to disable and enable USB ports.
- Added a feature to create custom dashboard views.
- Added a feature to group sets of custom data, timers, counters, and custom actions.
- Improved detection and notification of possible network configuration problems.
- Fixed an issue with voltage regulation and loadsharing that was noticeable on systems with large numbers of rectifiers.

2.9. Application release 6.20

Released: February 2020

Contains the following significant changes:

- Added support for ending a battery test based on state of charge (SOC).
- Added support for upgrading the operating system via a web browser.
- Added support for setting some controller configuration from SNMP.
- Added Configuration Hints to help identify system states (such as Temperature Compensation) and potential configuration issues (such as missing or incorrectly configured settings).
- Added Power Flow for Line Power Systems. Also added the ability to show power flow between a DC system and AMPS HP2 modular inverter systems when those systems are on different controllers.
- Added Configuration Restore Points to better manage storing and restoring configuration files.
- Added basic support for AC and DC generator control.
- Added AC current to performance log for AMPS HP2 modular inverter systems.
- Added support for starting timers manually.
- Added support for the Alpha® XMBS Smart Bypass.
- Added support for Controller Redundancy.

2.10. Application release 6.10

Released: October 2019

Contains the following significant changes:

- Added a feature to automatically back up configuration to USB drive on a schedule.
- Added a feature to manually set the bay/shelf/slot ID of CAN devices that do not automatically provide this information.
- Improved the way time data is displayed and entered as configuration.

- Added basic support for a generic AC Input source to allow for mapping rectifiers to different AC inputs.
- Added a disconnect that can be used for load shedding.
- Added a feature to allow an ADIO relay to be used to indicate when the ADIO loses CAN communication. This functionality requires a firmware upgrade on any supported ADIO device.
- Added shunt and transducer to allowable FXM HP UPS inventory.
- Added power Outage Logs Section under Working with logs.

2.11. Application release 6.00

Released: July 2019

Contains the following significant changes:

- Support for distribution systems in Power Flow.
- Added a Test Alarm button for each alarm.
- Improved filtering and searching on the web interface.
- Improved Add Load/Shunt Pairs wizard and Map Shunts to ADIO Inputs wizard to allow naming and manual mapping.
- Support for French language.
- Improved battery configuration based on battery model number.
- Added multiple scrollable screens on the LCD dashboard.
- Added an SNMP table to view active module alerts.
- Support for FXM HP Rugged UPS Module.
- Added a system shortcut page to LCD. Accessed with button press on the LCD dashboard.
- Support for the current transducer IPM (interface and power module).
- Added ability to reset the IP address from the OLED display on in-shelf controllers.
- Added ability to set up a datalog to capture a sample on a change in value.
- Added a new user role for Restricted Operator. Restricted Operator does not have permission to add or remove items from systems.
- Added more rectifier information to the rectifier details screen.
- Added option to include T2S configuration and event log to diagnostic export.

2.12. Application release 5.20

Released: March 2019

Contains the following significant changes:

- Added support for TACACS+ remote authentication.
- Added support for multiple battery strings.

- Added a generic external DC source to properly account for other sources of current on the DC bus, like photovoltaic panels.
- Added support for Power Flow display of AMPS HP2 modular inverter systems.
- Added support for AMPS HP2 systems data over Modbus TCP/IP.
- Improved display of data for loads, shunts, rectifiers, converters in the LCD Inventory Summary page.
- Improved performance of SNMP.
- Added a feature called Data Sharing to share a limited amount of data between Cordex® CXC HP controllers.

2.13. Application release 5.10

Released: November 2018

Contains the following significant changes:

- Added a feature to download inventory to a USB drive or to the PC. This includes most configuration and status values that are displayed on the user interface.
- Add a feature to disable write access through the web browser unless overridden by a local user through the LCD.
- Added a new battery conditioning mode for Boost.
- Added user configurable termination conditions to Equalize and Elevated Absorption modes.
- Added a new type of inventory called General Purpose Transducer, similar to a current transducer. This inventory can be created in a DC system, Converter system and Auxiliary system.
- Modified the limitation of 10 distribution subsystems (BDFB, E2, User Defined) to allow more E2 systems. Up to 40 E2 subsystems can be supported if there are no other BDFB or User Defined subsystems created.
- Fixed an issue with the SNMP trap destination port always being set to 162, even if configured as something else.

2.14. Application release 5.01

Released: August 2018

Contains the following significant changes:

- Full Modbus TCP support for the DC System, controller, custom data, timers, counters, and user alarms.
- Added a wizard to help configure multiple shunts and associated loads in the DC system.
- Fixed an issue with setting the 'True If' value for custom data state variable when the variable was a boolean.
- Added a user configurable startup delay for alarm processing to avoid nuisance alarms and traps.

- Fixed an issue with the bus voltage fault status of a disconnect when the Invalid System Voltage alarm was disabled.
- Limit response to SNMP GetRequests to five per second to avoid excessive CPU usage.
- Added additional statistics for total output current performance log of the DC system to keep track of top three hourly average maximums.
- Fixed an issue with display of temperature in Fahrenheit on the Datalogs.

2.15. Application release 5.00

Released: May 2018

To upgrade to this version from version 4.20 and previous, it is necessary to first install version 4.90.

Contains the following significant changes:

- Power Flow view for the DC System to visually show system status and important information.
- Support for HTTPS secure web server protocol.
- Support for RADIUS remote authentication protocol.
- Allow user customizable alarm names and the ability to hide default name/ID strings.
- Added ability to set the thresholds used to decide when a battery is charging or discharging for better support of systems with light loads and large batteries.
- Added drop-down navigation links to the menu bar.

2.16. OS release 6.30

Released: July 2020

Contains the following significant changes:

- Further improvements to flash disk error handling.
- Corrected flash timing parameters for improved reliability and faster boot times.

2.17. OS release 6.20

Released: February 2020

Contains the following significant changes:

- Drastic reduction in the likelihood of random boot failures
- Proper detection and handling of bad flash sectors to improve reliability and longevity of flash

2.18. OS release 6.00

Released: July 2019

Contains the following significant change: Improved longevity and operation of non-volatile memory.

2.19. OS release 5.20

Released: March 2019

Contains the following significant change: Changed RAM timings for better compatibility with different RAM chips.

2.20. OS release 4.70

Released: February 2019

Contains the following significant changes:

- Improved flash programming reliability
- Added feature to allow application to start a flash refresh for flash used by OS
- Support for VLAN
- Fix for clock overflow

2.21. OS release 2.20

Released: August 2015

Contains the following significant change: Support in-shelf controller product

2.22. Known issues

- The Default Power Flow and Default Dashboard settings have been obsoleted and no longer appears on the web interface. These settings are incompatible with the new web interface menu navigation.
- If using application version 7.10 on an in-shelf controller (for example, Cordex® CXCM1 HP controller), the backup, restore, and application upgrade features via a plugged in USB drive will not succeed. Please upgrade to application version 7.20 via a web browser to restore this functionality.
- For application versions previous to 7.10, if a restore is initiated and it fails, it is recommended to restart the controller and attempt the restore again.
- For application versions 6.30, 7.00, and 7.01, if the DNS address or Gateway address for an ethernet port is set to 0.0.0.0 then an OS upgrade could cause the ethernet configuration to not resync on startup. The DNS address or Gateway address should be filled in with a correct address or left blank.
- If a module has an alert when it is first powered on, the alert will not appear in the alert log. It will, however, be shown in the modules active alert table.
- In version 6.00, on systems with high voltage rectifiers (except 125 V/4.4 kW), a Rectifier Configuration Error alarm will occur. This alarm cannot be cleared. Upgrade to version 6.10, or downgrade to version 5.21 or earlier to solve this problem.

- In version 4.10, the SNMP trap varbinds **controllerInfoName** and **alarmSeverity** swapped position. This was remedied in version 4.20 so that the varbinds match the position as specified in the MIB as they did in versions previous to 4.10.
- When using a MIB browser to read controller data that represents a state, the numeric value of the state is moved to the dataNumberValue column (from the dataStringValue column) and its string value is now shown in the dataStringValue column.
- Downgrading controller software
 - Downgrading the controller software should be a rare occurrence. When software is downgraded, any configuration settings for features that don't exist in earlier versions are discarded. Because some configurations are discarded, the controller may require manual intervention to ensure every setting is correct. Restoring a backup file that was made with the earlier version of software is recommended instead.
 - In versions 2.X and 3.X of the software, we found two issues. The first is that when the software encountered an inverter or distribution system that it didn't understand, the software discarded more data than expected. The second is that when a custom data variable had data discarded, the controller would crash and not recover.
 - If a downgrade from version 4.00 software becomes a necessity, you can avoid these problems by deleting all inverter systems, distribution systems, and all custom data before performing the downgrade.
- Importing configuration files from later versions to earlier versions may fail - especially if the controller is running a version previous to version 4.00. If the import fails it may be because it contains new systems or custom data that uses variable values that do not exist. Try importing using a configuration file that doesn't contain inverter systems, distribution systems, or custom data.
- Importing configuration files from earlier versions to later versions can have some quirks. Controller features which did not exist in the earlier version will not have any settings saved in the configuration files exported from those earlier versions. Therefore, any configuration of these new features on the Controller will not be overwritten by the old configuration file. If a configuration file which sets these features back to their defaults is desired, it must be exported from a version in which the features exist.
- File upload works in the current version of Microsoft Edge, Internet Explorer, Google Chrome, Mozilla Firefox, and Apple Safari. File upload does not work in Internet Explorer 9. If using Internet Explorer 9, you can not upload the Cordex® CXC HP controller application upgrade or the ACAN files for CAN module upgrades.
- Counter and timer values in the **Counters** and **Timers** tables found under **ControllerProgrammabilityCustom Data** do not persist, they revert to their default values on a restart.
- The LCD does not currently support accented characters for passwords or aliases.

- Performance logs and Datalogs cannot run if there is a **Clock Error Alarm**. Once you correct the clock error alarm, it is a good idea to restart the controller to ensure that all of the logging starts up properly.
- The Datalog has a **Capture When True** configuration field that is used to control when data is captured. If you delete the value that **Capture When True** is pointing to (for example, a **Custom Data** value), the **Capture When True** field should change to Unknown but does not use. The user has to manually set this field back to Unknown or the Datalog will continue to use the old value.
- Custom data will sometimes give an error message **Variable Not Mapped** when the real error message should be **Variable Has a Value of Unknown**.
- Digital input state for digital inputs on BDFB devices was corrected. If a version 3.22 or earlier configuration file is uploaded, the following configuration fields may not be imported as expected. Check the following for correctness: BDFB digital input **Active When** field; the custom data variable using a BDFB digital input; and the user alarm using a BDFB digital input.
- If the Disconnect Active alarm is active, and the relay is unmapped from the disconnect, the alarm will not clear. To clear the alarm, remap a relay and clear the alarm condition, or remove the disconnect from the system.
- The in-shelf controller display does not display auxiliary systems. When one of these systems is selected for display, the display shows the text **No System**.
- Due to performance constraints on the controller, it is recommended to create no more than a total of five Smart BDFB or User-Defined distribution subsystems, or 40 Smart E2 distribution subsystems. This difference in limit is due to Smart BDFB and User-Defined subsystems requiring more processing power than Smart E2 subsystems due to the amount of data provided. A combination of the two limits can also be created (for example, three Smart BDFB subsystems and 16 Smart E2 subsystems). If a DC system is also required, then the recommended limit is no more than three Smart BDFB or 24 Smart E2 subsystems. These recommendations assume no more than light (10 datapoints) SNMP polling. If more SNMP data is required it is recommended to reduce the number of BDFB or E2 systems to compensate.
- Events that occur very early during the controller startup process may be logged with a time-stamp that is in UTC time rather than local time.
- A lightly loaded or phase unbalanced inverter system displays inaccurate readings for some values. When a system is loaded sufficiently, the readings will be correct.
- In version 6.00 and later, the Battery Temperature Anomaly alarm is disabled by default on the Battery. If it is required, set up one or more battery strings to use this alarm.
- When using the UPS-MIB with the FXM HP UPS, the controller will send two alarm traps. One is from the UPS-MIB, the other is from the ALPHA-RESOURCE-MIB .

- When creating a new Generator Start Condition or Stop Condition with a Value to Test that is measured in time with the 'd h m s' format, the Limit cannot be entered in 'd h m s' format. Instead, it must be entered with the units shown in the entry. For example, 3m 0s may have to be entered as 180s.

3. Introduction

The purpose of this document is to provide simple and complete information on how to use Cordex® High Performance (CXC HP) system controller and software. It contains an overview of the software features, on-site setup, and operation of the controller, as well as information on creating, configuring and maintaining your system using the controller.

3.1. Using the Cordex® CXC HP Controller Software Manual

3.1.1. Purpose and audience

The audience of this document are technicians and or facility operators tasked with installing, programming and commissioning, maintaining or troubleshooting the power system. When using the controller there are a variety of ways to perform most tasks. This document covers using the touchscreen display, as well as the web interface.

3.1.2. Knowledge and permissions

We assume you have a good working knowledge of, and access to, the following:

- Ethernet cables and TCP/IP settings needed to connect your computer to the controller
- Current version of Microsoft Edge, Google Chrome, Mozilla Firefox, or Apple Safari
- Power system that the controller is controlling
- Controller login passwords and the appropriate level of permissions

3.2. Product overview

This section provides an introduction to the controller, the controller software, as well as a brief overview of what the controller does, how it works, and an image of a typical network configuration. The Cordex® CXC HP controller (2RU model) has the following features:

- **Front touchscreen:** Full color touchscreen liquid crystal display (LCD), to access controls and menu items by using fingertip touch or a stylus.
- **Home button:** Provides the ability to go directly back to the home screen from any menu.
- **Front panel reset:** For emergency use only to restart the controller if the unit touchscreen or home button are not responding.
- **Front panel LEDs:** For alarms, progress and status indication.
- **Audio speaker:** Built-in audio speaker tones during active alarms and can be disabled if required.
- **Ethernet:** Dual 10/100BASE-T Ethernet ports for connection on both the front and rear of the controller for remote or local communication.

- **USB:** Dual ports on both the front and rear of the controller for upgrades or file management via a standard USB drive.
- **CAN:** Dual independent CAN bus ports for communication with the Cordex® and AMPS family of products.
- **Real-time clock with field replaceable lithium battery:** Allows timestamps on alarms and events.
- **System fail alarm/relay:** Activates when there is a major internal failure. During such a condition the unit attempts to reset.

Figure 3-1 Cordex® CXC HP controller (2RU model)

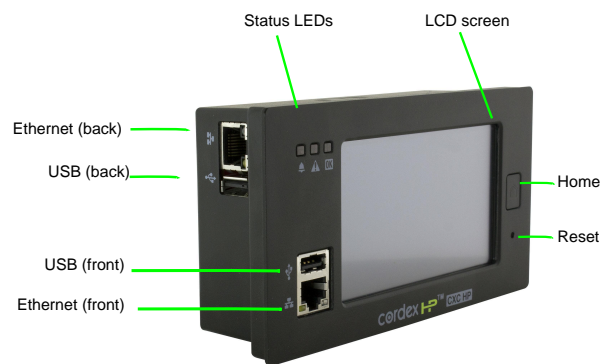

3.2.1. What does the Cordex® CXC HP controller do?

The Cordex® CXC HP controller family provides centralized setup, control, and monitoring of power systems. This can range from simple monitoring and threshold alarms for temperature, voltage and current, to advanced battery charging and diagnostic features.

The controller provides Ethernet ports allowing for network, LCD, and local laptop access to the controller including both web and SNMP interfaces.

The controller supports CAN ports to allow up to 254 power and ADIO modules to be controlled and monitored. The controller uses external analog and digital input and output (ADIO) modules to monitor electrical signals (such as temperature, voltage, and temperature) and generate electrical signals through relays.

The most commonly used ADIO peripheral is the Cordex® CXC HP L-ADIO peripheral for low voltage systems which includes:

- Eight digital inputs
- Four voltage sensors
- Four temperature sensors

- Four current sensors
- 12 Form C relay outputs

See the *Reference* section for a full list of power and ADIO modules that are supported by the controller.

3.2.2. Watchdog alarm



The **System Fail Relay** activates (de-energized) when there is a major internal failure if the controller is not running properly. The unit would attempt to reset.

The relay is energized when the controller software starts up. The relay remains energized during normal operation. If the controller loses power, or reboots, the relay is de-energized, which can be used to indicate an alarm condition.

When the hardware watchdog timer is not updated by the controller software for more than 30 seconds, the controller is determined to be not running normally. After 30 seconds, the relay will be de-energized, and the unit would reset.

3.2.3. Typical system configuration

The controller is a scalable software platform that allows multiple systems to be created and managed by one controller. The user interface is organized around system inventory so you only see the systems that you have created and you can manage them independently. Both the web interface and the LCD provide a summary of all systems monitored by the controller as well as controller and alarm information.

The figure below shows a specific DC power system with the following elements:

- Cordex® CXC HP controller and ADIO modules with CAN bus connections
- One or more rectifiers
- A battery string
- A shunt to measure battery current
- A battery low voltage disconnect (LVD) in series with the battery string

Figure 3-2 Typical DC system configuration

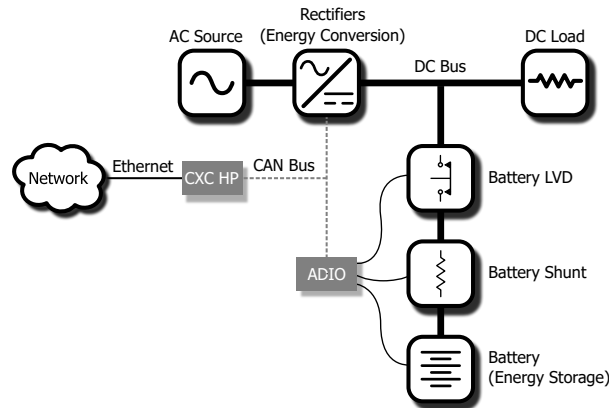

3.2.4. How to get help

The controller has **Help** on the web interface and the LCD dashboard, but not on the in-shelf display (Cordex® CXC HP in-shelf controllers have a small OLED display). The **Help** menus provide a description of the product feature, its function and the typical default values. Each of the LCD menus has a descriptive **Help** statement. For example:

From the LCD dashboard select **Menu > Alarms > Settings > Alarm Cut-Off and Global Alarm Settings** and the screen provides information about the default cut off time.

The **Help** icon displays on a screen such as, **Menu > Controller > Settings > Site Information > Description > Name**.

Figure 3-3 Accessing Help on the LCD interface

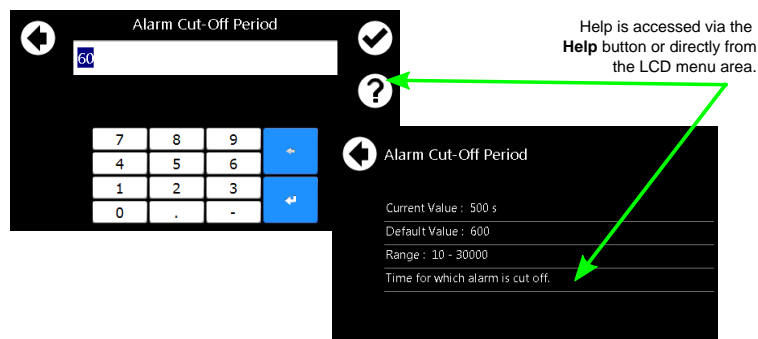

Accessing Help on the web interface:

Select any of the items on the dashboard area and the **Help** field displays. The help menus provide a description of the item, and in most cases a default value for the field.

Figure 3-4 Accessing Help on the web interface

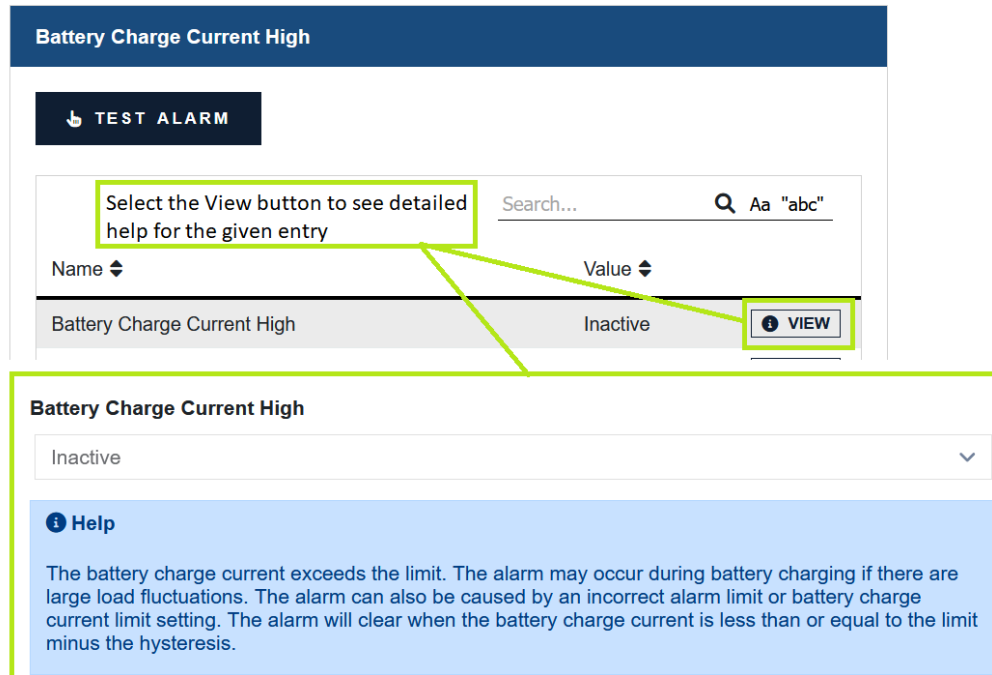

The software manual can be uploaded to the controller for quick access. Follow the steps in the **Uploading the Software Manual** section.

Once uploaded, access the manual via the web interface by selecting **Accounts** icon on the right of the top bar, which looks like a small person.

Figure 3-5 Accounts and shortcuts

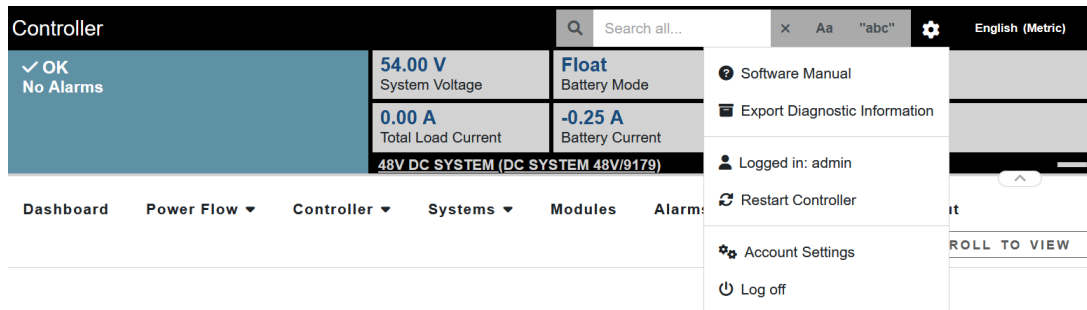

4. Getting started

This section explains how to navigate the menus and basic connection, monitoring, and control functions using the LCD, the in-shelf display, and the web interface of the controller.

4.1. Apply power

The controller and most ADIO modules are designed to run on battery or DC bus power for 12, 24, and 48 volt systems. A redundant input power module (PN: 0180045-001) is available to simplify the connection of power from above and below a battery LVD to both the controller and ADIO modules.

1. Apply power to the controller (for example, close battery breaker or rectifier input and output breakers).
2. The LEDs start cycling, and then after a few seconds the Cordex® CXC HP logo displays.
3. Wait for approximately about 30 seconds. The LEDs will turn off and the controller software will load.
4. Once the software is loaded, the green LED turns on (it may turn to yellow or red depending on the controller alarm state).

The front panel display shows the dashboard.

4.2. Connect to the controller

There are three options for connecting to the controller web server from a web browser running on your computer:

- Through a local area network (LAN)
- Direct connection with IP auto-configuration
- Direct connection with static IP address



Notice: *If the **Require Login for Sensitive Information** setting is enabled, a login will be required to view the IP settings on the LCD.*

Factory default passwords

Obtain the user account information and passwords from the system administrator. The default values are:

- Default User Name: `admin`
- Default Password: `admin`



Notice: *When using the in-shelf display, you can view, but not edit the IP settings.*

Connection through a LAN

1. Use the LCD to verify that the Ethernet port is configured to acquire an IP address automatically. **IP Address Mode** can be found in the **Configuration** table at: **Shortcuts > Ethernet > Ethernet/Rear**.



Notice: Enable DHCP at **Controller > Communication > Ethernet**. Go to the desired ethernet port and select the **Change Network Configuration Wizard** button in the **Configuration** table.

2. Plug an Ethernet cable in to the rear Ethernet port and to your LAN. The computer that you want to connect the controller to must also be on this same LAN.
3. Use the LCD to determine the IP address automatically assigned to the controller. You can use either the IPv4 or IPv6 addresses. IP address information can be found at **Shortcuts > Ethernet > Ethernet/Rear**.
4. Enter this IP address into the address bar of your web browser and select enter. The web **Login** screen displays.

Direct connection with IPv4 auto-configuration

1. If available, use the LCD to verify that the rear Ethernet port is configured to acquire an IP address automatically. **IP Address Mode** can be found in the **Configuration** table at: **Shortcuts > Ethernet > Ethernet/Rear**.



Notice: Enable DHCP at **Controller > Communication > Ethernet**. Go to the desired ethernet port and select the **Change Network Configuration Wizard** button in the **Configuration** table. .

2. Connect an Ethernet cable to the rear port of the controller and your computer. Your computer must be configured to obtain an IP address automatically.
3. Use the LCD to determine the IP address that has been automatically configured. The IP address should use the dotted-decimal format: 169.254.XXX.YYY.
4. Enter this IP address into the address bar of your web browser and select enter. The **Login** webpage displays.

Direct connection with an IPv6 link-local address

1. Connect an Ethernet cable to the front or rear port of the controller and your computer. Your computer must also be configured to allow IPv6 addresses to be used.
2. Use the LCD to determine the IPv6 address that has been automatically configured. The IP address should use the colon-hexadecimal format: fe80::www:xxx:yyy:zzz
3. Enter this IPv6 address into the address bar of your web browser and select enter. The web **Login** screen displays.

Direct connection with default static IPv4 address

Contact your IT department if you are unsure of how to do this.

1. Connect an Ethernet cable to the front port of the controller and to your computer. Your computer must be configured with a static IP address (for example, 10.10.10.202) and subnet (for example, 255.255.255.0).
2. Use the LCD to verify that the IP address for the front port is similar to your computer's IP address (for example, 10.10.10.201).
3. Enter the controller's IP address (for example, http://10.10.10.201) into the address bar of your web browser and select enter. The **Login** webpage displays.

4.2.1. In-shelf controller

Some systems may have an in-shelf controller display. They do not require a login. The display enables you to execute a set of commands much like the LCD on the 2RU controller.

From the dashboard, use the **Select** button to enter a menu. When you enter a menu, the top item is highlighted. To go to another menu scroll through using the **Forward** and **Back** buttons. To execute a highlighted menu item, select the **Select** button.

To set a default system or disable USB maintenance actions go to **Controller > Settings > User Interface > In-Shelf Controller Display Preference**stable from the web interface.

4.3. Navigating the controller user interface

Both the web interface and the LCD dashboard provide a summary of system, controller and alarm information. When you login to the web interface or the LCD, the dashboard provides an at-a-glance view of the overall systems.

4.3.1. Log into the controller

You can login to the controller via the LCD or the web interface.

If the IP address has not been configured, see the previous section, *Connect to the controller*.

1. Enter the default IP address into the web address bar on the computer.
2. Log into the web interface.

- a. Enter the default user name: *admin* (or the user name supplied by your administrator).
- b. Enter the default password: *admin* (or the password supplied by your administrator).



Notice: *Once logged in, the session expires after 3 hours, or after 60 minutes with no activity.*

Log into the LCD:

3. From the main dashboard of the LCD, select **Login**.
 - a. Enter the default user name: *admin*.
 - b. Enter the default password: *admin*.
4. Select the check mark to complete the login process.

The main dashboard displays.

4.3.2. Controller menu

The top level controller menu bar contains eight items: **Dashboard**, **Power Flow**, **Controller**, **Systems**, **Modules**, **Alarms**, **Logs**, and **Shelf Layout**. Similar menu items are available under the "Menu" button on the LCD, with the exception of **Dashboard**, **Power Flow**, and **Shelf Layout**. In most cases, these top-level menu items are further subdivided into sub menus. If you select the top-level item, you will see a display of all sub menus under that item, and can then select any level of the menu to jump to that page directly. If there are no sub menus under the menu, you will navigate to that page of the controller immediately by selecting the top-level menu. Menus with sub menus can be identified by the small down-arrow icon beside the menu name.

The following is an overview of the menu structure under the top-level item **Controller**, which is displayed when you select **Controller** on the main menu.

Figure 4-1 Menu structure

ABOUT	SETTINGS	COMMUNICATION
General	Site Information	Ethernet
Storage & Memory	Time & Date	CAN
Factory Information	Speaker	SNMP
	User Interface	Modbus
	Maintenance Mode	Email
		Web Server
		Data Sharing
		Published Data and Systems
		Data Subscriptions
		Syslog
		Soft Shutdown
		Controller Redundancy
FILES & UPGRADES	USERS & SECURITY	PROGRAMMABILITY
Configuration & Software Backup	Users	User Alarms
Software Upgrade	Remote Authentication	Custom Data
Licenses	RADIUS	Scheduler
Software Manual	TACACS+	
	Remote Configuration	
	Lockout	

4.3.3. Overview of the LCD

The LCD is a touch-sensitive color panel on the front of the controller. The display is always on when the controller is first powered up but after 20 minutes of inactivity the user will be logged out and the display will be turned off. Touching the home button or the LCD in any spot reactivates the LCD screen.

It is possible to change the inactivity time-out of the LCD in the **Controller > Settings > User Interface** menu, in the **LCD Preferences** table. The time-out can be set to 20 minutes, 1 hour, 4 hours, or 8 hours. However, to prevent the LCD from wearing out, it is strongly recommended to leave this setting at 20 minutes, unless temporarily changing it for commissioning or demonstrations purposes.

The LCD is most responsive to touch when firm, substantial pressure is applied. The LCD does not usually respond to light, quick taps. A stylus may be used if desired.

The default screen that displays on the controller when it is powered up and running normally, is called the dashboard. See the following figure.

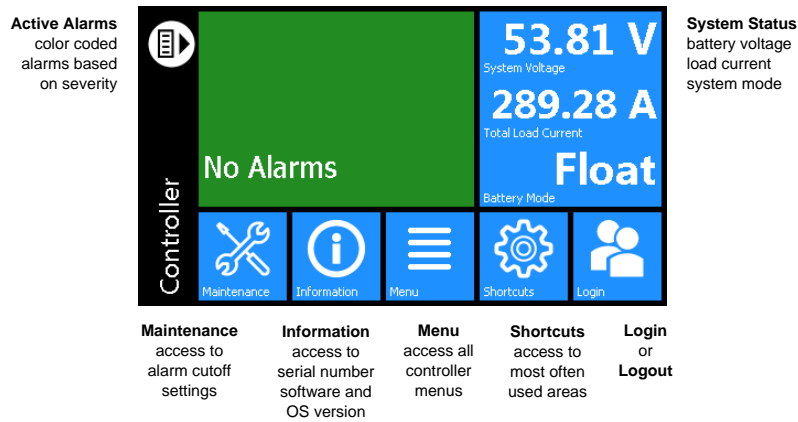
Figure 4-2 Controller LCD dashboard

The upper-left area of the dashboard is the **Alarm** tile. If there are active alarms the LCD will show the top three active alarms.

If there are no alarms in the system, the Alarm tile displays **No Alarms** and the display will be green in color. If there are active alarms the color will match the state of the highest priority alarm as follows:

- Green for no alarms present
- Yellow/orange for minor alarms
- Red for major and critical alarms

Pressing the **Alarm** tile takes you to the **Active Alarms** menu to see a list of active alarms, active alerts and hints. From the **Active Alarm** view, you can also activate the alarm cutoff (ALCO) as well as press the individual alarms, alerts, and hints to get detailed information on each.

 **Notice:** Alarms, alerts, and hints have specific definitions:

- **Alarm:** Has user configuration and can send email or SNMP notifications.
- **Alert:** Status from modules like rectifiers or converters.
- **Hint:** Information about system activity or possible configuration problems; can be dismissed.

The upper-right area of the dashboard is the **System Status** tile. It displays battery voltage, total load current and the Battery Mode of a DC power system. Selecting the **System Status** tile takes you to the shortcuts pages for that system, if it exists, or the status page for that system.

For support of controllers that manage multiple power systems, there is a configuration option which allows the dashboard to shrink the alarm tile to show an extra System Status tile.

Below the **Alarm** and **System Status** data tiles there are five buttons providing access to the rest of the controller's functionality.

Maintenance: Provides easy access to frequently-needed maintenance tasks including the Alarm Cut-Off. Pressing the Maintenance button takes you to the Maintenance screen. The first page contains general shortcuts, like **Alarm Cut-Off**, **Forget All in Comms Lost** and **Replace ADIO**. Each system defined is also listed on the main page. Pressing a system button provides access to a page of system-related maintenance shortcuts.

Figure 4-3 Maintenance page

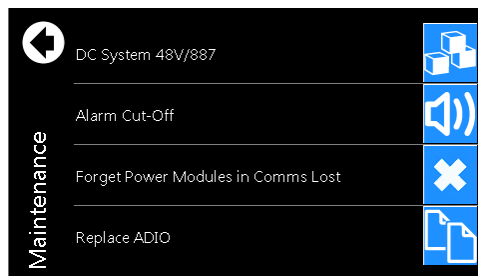
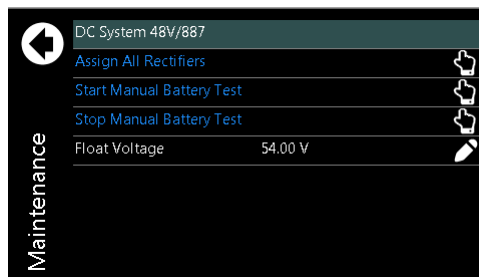

Figure 4-4 System maintenance page



Information: Provides contact information for technical support, as well as general information about the controller such as the serial number, software version, and Operating System version.

Menu: Provides access to the controller menu, which follows almost the same menu structure as the web interface, with some exceptions. Some examples of menus not available on the LCD are:

- **Power Flow**
- **Shelf Layout**

Shortcuts: Provides quick access to several key functions that are used often, such as the **Ethernet** settings. The **Shortcuts** menu also provides access to functions only supported via the LCD such as:

- USB file browser
- Backup
- Restore

- Display Calibration

4.3.3.1. LCD menu button

This section provides an overview of all the LCD menus on the controller. The LCD has a menu structure that mirrors the web interface. Select the **Menu** button on the LCD dashboard to navigate and select menu items. The menu items are as follows:

- Controller
- System
- Modules

- Alarms
- Logs

When a menu item is selected, it is highlighted in blue, and an **arrow** displays on the right side of the screen. Select the arrow to navigate to the next page.

Figure 4-5 LCD menus page

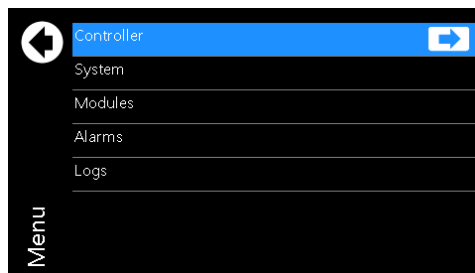

For example, select **Menu > Controller > About > General** to view detailed information about the controller.

Figure 4-6 Controller status page

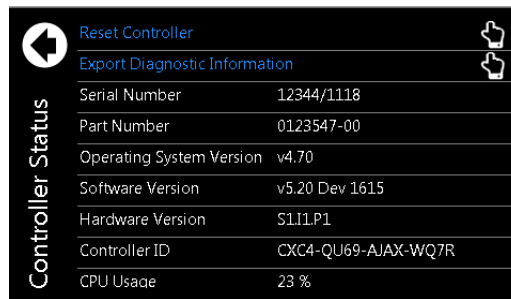

When selected, some views display a **pencil** or **hand** icon on the right side of the screen which means you can edit settings or perform actions.

For example, from the **Controller > Settings > Time and Date** screen select the **pencil** icon to set the following:

- Current Time and Date
- Time Zone
- Daylight Saving Time Method
- Network Time Server Address

Figure 4-7 Time and date page

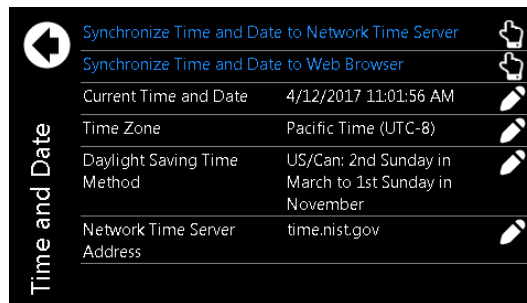

To edit the time zone, you can choose from the list of supported time zones.

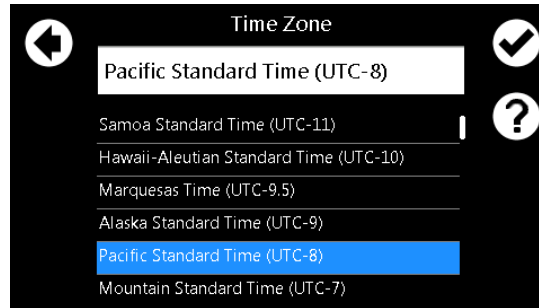
Figure 4-8 Time zone page

If Network Time Server Address is selected, a text field, and on screen keyboard displays.

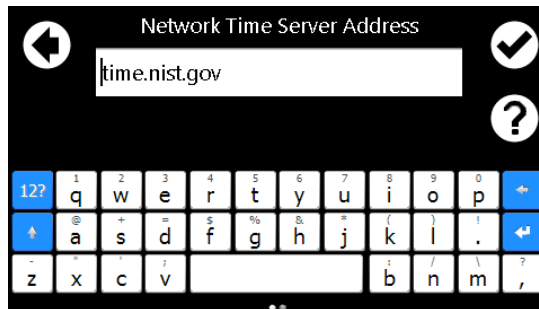
Figure 4-9 Network time server page

Selecting the **back arrow** cancels an edit, selecting the **checkmark** accepts the changes. Selecting the **Help** icon displays a help screen with more information about the item. If the edit is unsuccessful an error displays in red text below the text box. You can either try again, or select the back arrow to abandon the change.

Another screen that displays when selecting items, is the **Execute** screen. For example, **Synchronize Time**. Most edits and executable actions (except ALCO and Restart) require you to login. If you select an editable item or executable action before logging in, the controller responds providing an opportunity to log in and then continue with the action.

When you select the **back arrow** the action is canceled. If you select **Execute**, the command is executed, and the controller provides feedback on whether the action was successful.

Figure 4-10 Synchronize time

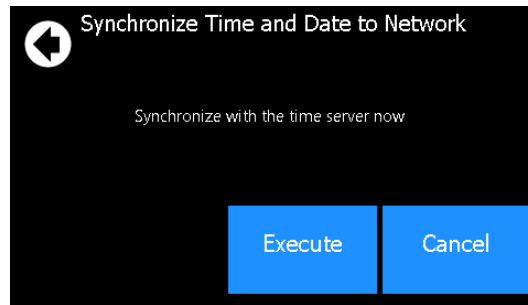

4.3.3.2. LCD shortcuts button

The LCD **Shortcuts** menus provide quick access to often-used areas of the controller menu, as well as additional functionality not available via the standard menus.

Figure 4-11 Shortcuts



Functions available through the **Shortcuts** menu are as follows:

Ethernet: Provides access to the **Controller > Communication > Ethernet** page, and displays information for each Ethernet port. Viewing and editing the Ethernet configuration is one of the most often-used features from the LCD. Selecting an Ethernet port from the list allows you to view and edit the detailed information for that port.

Figure 4-12 Ethernet page

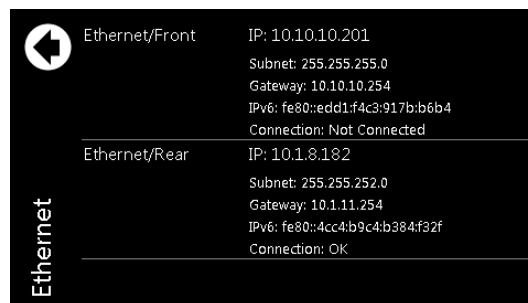

Inventory summary: Provides access to a special **Inventory Summary** page, which allows for a quick check of what devices are available. The top-level inventory page shows counts of each device type. Selecting the icon associated with that device displays a list of that type of device. Selecting an individual device from the list displays that particular device’s details.

Figure 4-13 Inventory summary page



Dashboard config: Provides a shortcut to the **LCD Preferences** page which provides the opportunity to switch the dashboard configuration between Automatic and Manual and also to change the LCD default between a single-panel view, dual-panel view, or a wide-data panel display. The dual-panel view has a single top alarm, and provides two system status data panels, which allows data points for two different systems (for example, DC and Converter) to be shown in the case of a multi-system configuration. The wide data panel view allows you to display six signals from a single system.

In Automatic mode, the dashboard shows a single panel view if there is one system, and a dual panel view if there are two systems.

In Manual mode a user can select the option to have the LCD main dashboard display only a single system, even if there are two installed.

Figure 4-14 Dashboard with multi-system panels

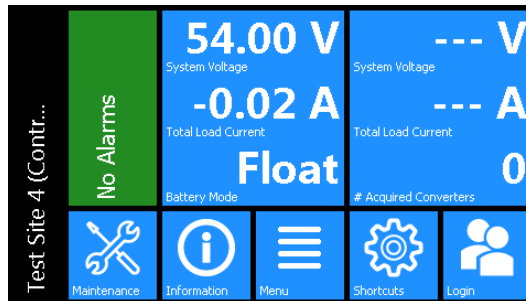
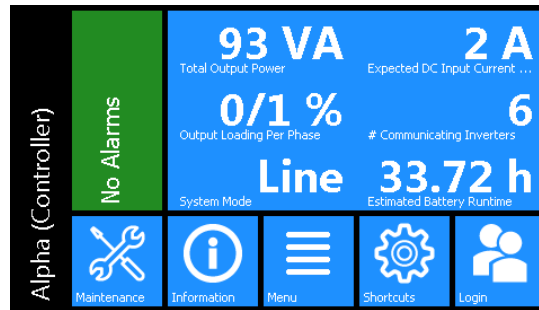



Figure 4-15 Dashboard using wide data panel view

To access the wide data layout, go to **Controller > Shortcuts > Dashboard Config > LCD Dashboard Option > Wide Data Panel**. If there is more than one system on the controller. Switching to **Wide Data Panel** from **Automatic** is a two-step process. Once **Wide Data Panel** is chosen, a specific system must be selected so that the data values display for that specific system.

Language: Provides access to the **Controller > Settings > User Interface > LCD Preferences > LCD Language** setting, where the language for the LCD can be changed to any of the available translations. Switch the language by selecting the desired language from the list then select the check mark. Controller supports three languages English (Imperial), English (Metric), and French.

Browse USB: Provides access to an LCD only function, which allows you to view the files on any USB drive that may be attached to the controller. If a file is selected from this view, the LCD goes to the available action screen for that file – for example, the LCD displays an upgrade screen if an application file is chosen from the USB.

 **Notice:** When using a USB drive with the controller, use a version 3.0 (or later) USB drive for best reliability. Once inserted, it can take up to 20 seconds for the controller to recognize a USB drive.

Export diagnostic information: Provides an option to export a Diagnostic Information Package containing important logs and a controller clone to a USB drive. This information is needed for any support requests. For more information on how to download, refer to the **Exporting Diagnostic Information** section of this manual.

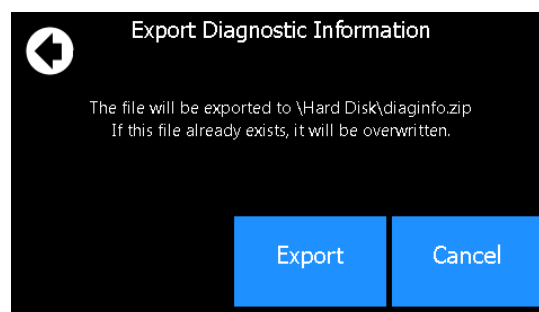
Figure 4-16 Export diagnostic information

Backup: Selecting this button, allows you to do a back-up of the system. It backs up the application, as well as the config file. These backups are saved on a USB drive.

 **Notice:** For the backup to work properly, only one USB drive should be attached at backup time. If a file named *Cordex HP.Backup* already exists in the root directory of the USB drive, it is overwritten with the current backup.

Figure 4-17 Backup



Restore: Provides an opportunity to insert a USB drive and restore a previously saved backup file.

Clock: Provides a direct link to the **Time and Date** screen.

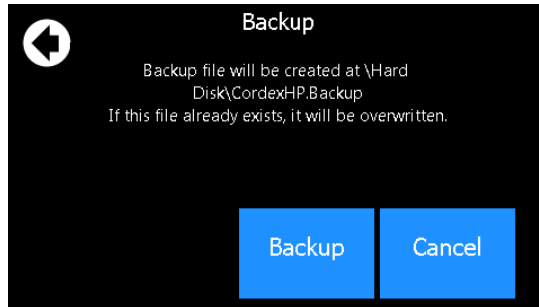
Speaker: Provides the ability to enable or disable the speaker.

Display: Provides the ability to re-calibrate the touchscreen.

 **Notice:** When recalibrating the touchscreen display, the final screen of the wizard will say: **Select the Enter key to accept the new settings. Select the Esc key to keep the old settings.** Select the touchscreen anywhere to accept the new settings. If using a keyboard, you have the option to select the ESC key to keep the old settings.

Reset: Provides a direct link to reset the controller.

4.3.4. Overview of the web interface

The dashboard is the default view displayed when you login to the controller via the web interface. It provides an up-to-date overview of most critical information of your system. It displays controller information, a system summary table, and the list of any active alarms.

The upper-left tile of the screen provides a color-coded live status view of these alarm notifications. The upper-right tile provides a system status bar with detailed information about the systems.

If there are active alarms, the **Alarm Notification** tile displays the last active alarm according to alarm priority:

- Red for major or critical alarms
- Amber for minor alarms
- Blue for warnings

Selecting the Alarm tile takes you directly to the **Active Alarms** menu.

If there are no active alarms, a **No Alarms** message will be shown. In some situations, the controller will provide hints as to certain behaviors of systems, or mis-configurations. If there are no alarms, one hint may be displayed below the **No Alarms** message. Hints are explained in more detail in later sections.

The upper-right tile displays **System Status Bar(s)** which contains summary information for the systems. Selecting the system link at the top of the **System Status Bar(s)** takes you directly to the **System** status screen.

The upper right-side of the of the web interface also provides the **Shortcuts** and **Language** dropdown menus. The small cog icon is the **Shortcuts** menu which provides a quick link to the user manual, account settings, and a few other often-used items. From the **Language** dropdown menu you can change the language from English to other languages as well as choose imperial or metric measurement units for the display.

Figure 4-18 Dashboard overview on web interface

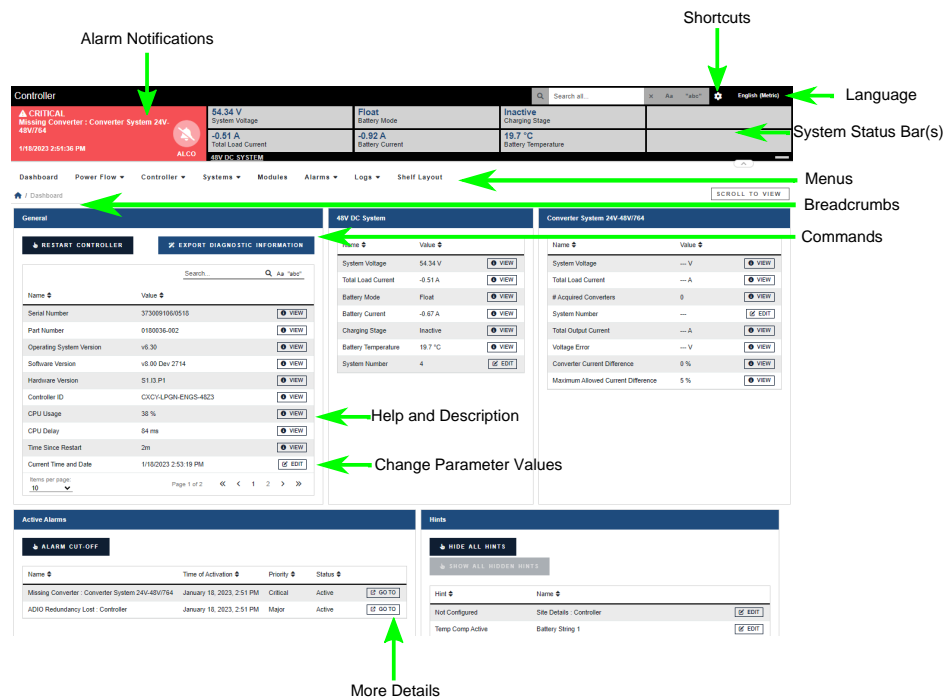

Under the **Alarm Notification** and the **System Status Bar** are the main menus for the controller:

Dashboard (Home), Controller, System, Modules, Alarms and Events, and Shelf Layout.

As you enter the menus, the interface provides a context sensitive breadcrumb trail at all levels so that you can “see” where you are within the system and go back to any previous menu. The lower area of the main dashboard contains system tables with detailed information about:

- Controller Status
- Systems
- Active Alarms

You can work with the system directly from this area.

4.3.4.1. Global search

Within the web interface, there is a search bar at the top-right of the screen. This search bar allows you to quickly find the following information:

- Configuration
- Alarms
- Buttons

To search, enter terms into the search box. After the search returns a result, you can select **Go To View** to go to the view the status of that Configuration, Alarm, or Button. For **Configuration**, you can select the **EDIT** button to directly edit this value.

The following example illustrates the usage of the search bar to find the **Output Voltage Low** alarm for a DC System.

Figure 4-19 Global search example

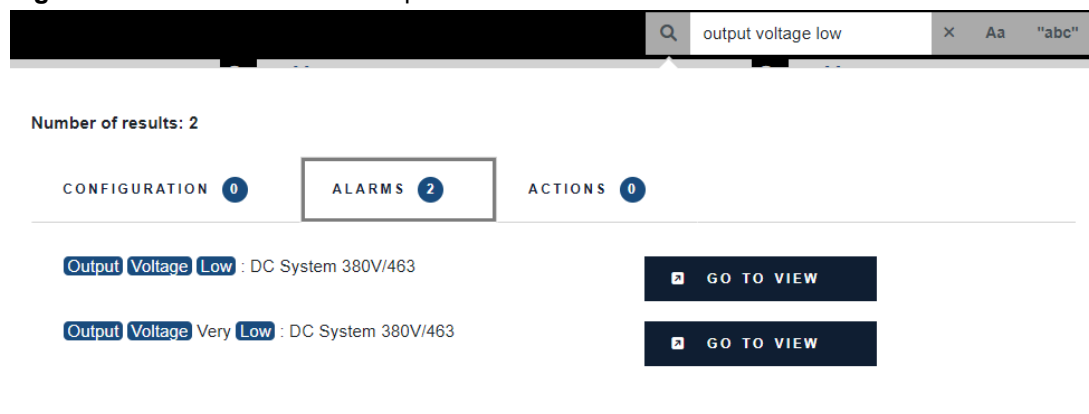

4.3.4.2. Paging, sorting, and filtering

Within the web interface there are three additional features that help you find information: paging, sorting and filtering.

Paging: Displays multiple page tabs on tables that have a large quantity of information. If there is too much information for one table the table’s lower edge contains a list of numbers which allows you to scroll through the information.

Sorting: Provides a way to sort the table columns, either ascending or descending similar to any standard spreadsheet program.

Filtering: Provides an easy way to refine the information shown in a particular table.

The search bar on the upper-left side performs a search on each of the space-separated terms in all columns of the table. The “Aa” toggle can be used to make the search case-sensitive, and the “abc” toggle can be used to only match whole words. For example, typing “dc system major” will display all alarms of priority Major on the DC System.

The following example shows these features on the **All Alarms** table.

Figure 4-20 Web interface table features

Name	Status	Limit	Priority	Relay
Output Voltage Very High : DC System 48V/338	Inactive	56.50 V	Major	---
Output Voltage High : DC System 48V/338	Inactive	55.50 V	Minor	---
Output Voltage Low : DC System 48V/338	Inactive	48.00 V	Minor	---
Output Voltage Very Low : DC System 48V/338	Inactive	46.50 V	Major	---
Invalid System Voltage Reading : DC System 48V/338	Inactive	5.00 V	Major	---
AC Input Voltage High : DC System 48V/338	Inactive	250.0 V	Minor	---
AC Input Voltage Low : DC System 48V/338	Inactive	198.0 V	Minor	---
Long Term AC Input Fail : DC System 48V/338	Inactive	10m	Major	---
Total Load Current High : DC System 48V/338	Disabled	--- A	Minor	---
Total Load Current Very High : DC System 48V/338	Disabled	--- A	Minor	---

4.3.4.3. Controller menu

This section provides an overview of the **Controller** menu. The controller area has a total of six sub-menus: **Status**, **Settings**, **Communication**, **Files & Upgrade**, **User & Security**, and **Programmability**.

About: Provides access to sub-menus providing various status information about the controller, including:

- **General:** General information and active user sessions. The **General** table includes a button to reset the controller or export diagnostic information.
- **Storage & Memory:** Flash refresh, flash disk, application storage, memory, and alarms tables.
- **Factory Information:** Factory information and branding tables.

Settings: Provides access to configuration sub-menus including the following:

- **Site Information:** Description and location tables.
- **Time & Date:** Time and date table for all related settings. You can also synchronize time and data to a network time server or to a web browser with the buttons.
- **Speaker** (if available): View the speaker state, enable or disable it, and edit the external speaker relay.
- **User Interface:** User interface, LCD preferences, in-shelf controller display preferences, file preferences, web interface preferences, custom views, and system dashboard values.
- **Maintenance Mode:** See status, alarms, and relay behavior during maintenance. You can also manually start and stop maintenance mode on this page.

Communication Provides sub-menus for the many different communication protocols the Controller supports, including:

- **Ethernet:** Configure Ethernet, ports, and VLAN support.
- **CAN:** Settings for the two CAN ports on the controller.
- **SNMP:** Configuration, SNMPv3 configuration, read communities, write communities, SNMP destination, SNMP and component reference.
- **Modbus:** Configuration, system device IDs, and Modbus reference tables.
- **Email:** SMTP configuration and email destination tables.
- **Webserver:** Webserver ports and secure web server.
- **Data Sharing:** A method for sharing data to another controller. Published data and systems and data subscription tables.
- **Syslog:** Configuration and syslog destinations tables. Select the SEND TEST MESSAGE TO ALL DESTINATIONS to test connected systems.
- **Soft Shutdown:** View and edit status and configuration tables.
- **Controller Redundancy:** A method for keeping configuration in sync with a backup controller.

Files & Upgrades: Provides access to sub-menus related to the various files that can be uploaded and downloaded to the controller, including config files, backup files, upgrade files, license files, and software manual files:

- **Configuration & Software Backup:** Import and export configuration files including clones. Create configuration restore points, export a controller backup, and view restore point information.
- **Software Upgrade:** Upload new controller software (application) and OS (operating system) to upgrade or download the controller.
- **Licenses:** Import and export the license key file, enable and disable temporary licenses, and view related alarms.
- **Software Manual:** Upload the HTML software manual to the controller.

Users & Security: This menu provides access to user configuration and other settings related to authentication and permissions, such as:

- **Users:** Configure users, view active user sessions, and machine account status.
- **Remote Authentication:** Configure RADIUS and TACACS+ settings.
- **Remote Configuration Lockout:** View and configure remote configuration lockout including status and related alarms.

Programmability: The controller provides some features to allow users to customize its behaviour, for example, custom alarms, a calculation engine, and a scheduler:

- **User Alarms:** Add digital user alarms and threshold user alarms.
- **Custom Data:** Custom data, counters, timers, and change field to variable actions.
- **Scheduler:** Scheduled actions and time spans.

4.3.4.4. Systems menu

This section provides an overview of the **Systems** menu.

Depending on a created system, there can be a variety of sub menus that will vary from system to system. For example, sub menus such as **Status**, **Configure System**, **Inventory**, **System Functions**, and more.

If the controller is new, and a system hasn't been created yet, then selecting the **Systems** menu on the navigation bar will lead to the **Add or Remove Systems** page. The **Create System** wizard can be selected in the table to launch the process to create a specific system. Follow the wizard step by step to create the desired system.

After the creation of a new system, the **Add or Remove Systems** table will be populated with the newly created system. To go to any created systems sub menus, select the **Systems** menu which will display created systems and their potential sub menus.

Note: Upper level sub menus are displayed in the navigation tree and there can be further lower level sub menus after selecting an upper level sub menu. For example, the **Battery** inventory item in a DC system can have battery strings. In this case, battery strings are not displayed in the upper level menu.

4.3.4.5. Modules menu

This section provides an overview of the **Modules** menu.

The **Modules** menu has the following tables: **CAN Modules**, **Power-Line Comms Modules**, **Firmware Upgrade**, and **Firmware Files**.

CAN Modules: Provides a table to view or locate all modules.

Power-Line Comms Modules: To view all PLC modules in this table, their parent CAN module must be part of a system.

Firmware upgrade: Provides a table to start and monitor a firmware upgrade.

Firmware files: Provides a table to view, upload, or delete firmware files.



Notice: *Even if a system is configured to auto-assign devices, once a rectifier has been unassigned from the system, it must be manually reassigned back into the system. This is necessary to avoid unintentional auto-assignment. If a device is unassigned using the **Forget** button, then it will auto-assign when discovered on the CAN bus.*

4.3.4.6. Alarms menu

The alarms sub menus are: **Settings**, **Active Alarms**, **Controller Alarms**, and **All Alarms**.

Figure 4-21 Alarms menu

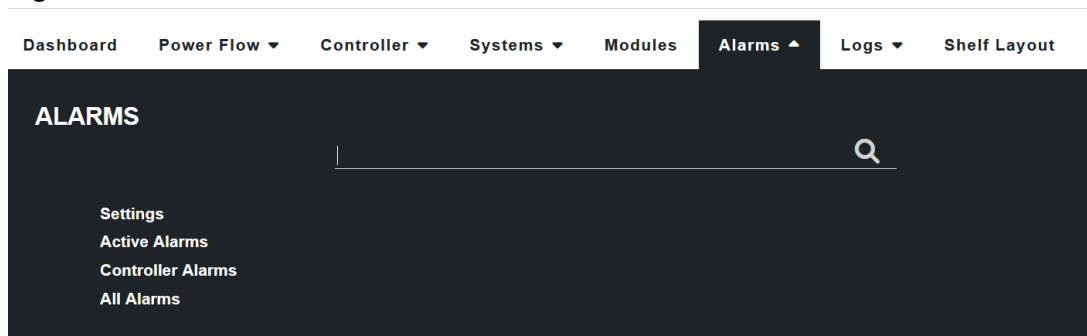

Settings: Provides alarm cut-off functionality, configuration, and settings for global alarm behavior. This menu also includes the **Alarm Summary Relays** table.

Active Alarms: Provides tables to view and configure active alarms, module alerts, and hints as well as an **Alarm Cut-Off** button.

Controller Alarms: Provides a table to view and configure alarms not belonging to a given system or module.

All Alarms: Provides a table to view and configure all possible alarms. Any alarms can be easily searched for and configured (for example, with a mapped relay) using this table.

4.3.4.7. Logs menu

The logs section has several log-related sub menus : **Events & Alerts**, **Battery**, **Power Outage**, **Datalogs**, and **Performance**. Every log can be exported to CSV files for further analysis.

Figure 4-22 Logs menu

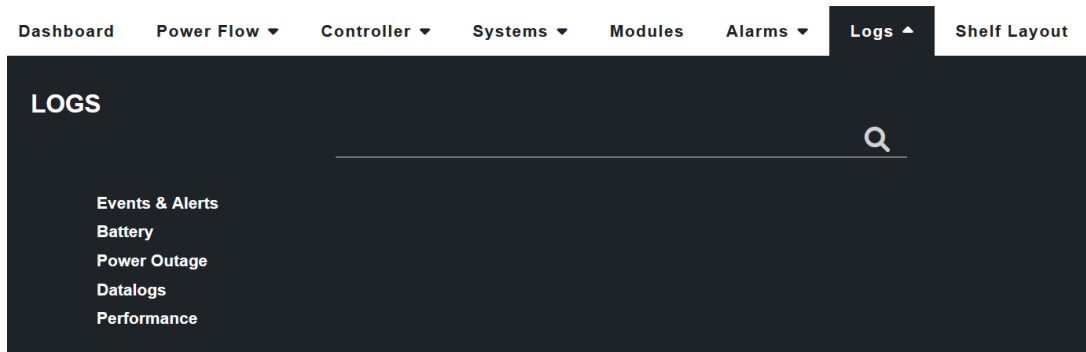

Events & Alerts: The **Events** table provides a list of system and controller events that record configuration changes, alarms and general controller and system operation. The **Module Alerts** table shows the module alert name and module serial number when a module reports an alert condition.

Battery: The battery log records the duration and change in capacity (Ah) for every charge and discharge of a battery. If you have **Battery Runtime & Health** enabled, the log will also record the change in State of Charge (SOC) and State of Health (SOH).

Power Outage: The power outage log records the start time, end time and duration of each power outage.

Datalogs: The datalog allows users to record measurements at set intervals over a period of time using the controller sensors and calculated values as inputs.

Performance: The performance log provides daily roll-ups with a minimum, maximum and average value for key usage statistics. For power systems, that usually includes the input voltage and current and the output voltage and current. For the controller, the CPU, and memory usage are tracked.

4.3.4.8. Shelf layout menu

The **Shelf Layout** page displays a virtual view of your shelf layout system. To display the physical representation of a system, a device must provide the bay ID, shelf ID, and slot ID information.

Figure 4-23 Shelf layout menu

	Slot 1	Slot 2	Slot 3
Shelf 1	⏏ ⚡ 0.02 A	⏏ ⚡ 0.00 A	⏏ ⚡ 0.00 A
Shelf 2	⏏ ⚡ 0.00 A	⏏ ⚡ 0.00 A	⏏ ⚡ 0.00 A
Shelf 3	⏏ ⚡ 0.00 A	⏏ ⚡ 0.00 A	⏏ ⚡ 0.00 A

From the **Shelf Layout** you can select any of the devices to be taken to the device details page.

The following modules support the **Shelf Layout** function:

- Cordex® HP 12 kW 48 Vdc rectifier system
- Cordex® HP LPS36 line power system
- Cordex® HP eLimiter+ distribution system
- Alpha® Inverter Module (AIM) 2500

If all the devices in a system do not have bay ID, shelf ID, and slot ID information then the view will switch to a simple table with each device on a separate row.

Refer to your device manual to determine whether your devices support this feature.

4.3.4.8.1. Configure shelf layout manually

If devices do not provide bay ID, shelf ID, slot ID information then the **Configure Shelf Layout** feature can be used to manually configure a layout. On the **Shelf Layout** page, a **Configure Shelf Layout** link is provided for DC systems and converter systems. If all the modules of your system have bay ID, shelf ID, and slot ID information, the button will appear on top of the system's shelf layout. Otherwise the button will appear on the simple table of modules.

To map your modules to the Shelf Layout:

1. Select **Configure Shelf Layout** to open the **Configure Shelf Layout** page
2. On the module you wish to map, select the **Locate** button. The physical module LED will begin to blink.
3. On your physical layout, locate the blinking module and make a note of the slot position.
4. On the **Shelf Layout** page, drag the module to the appropriate shelf/slot position on the layout grid.

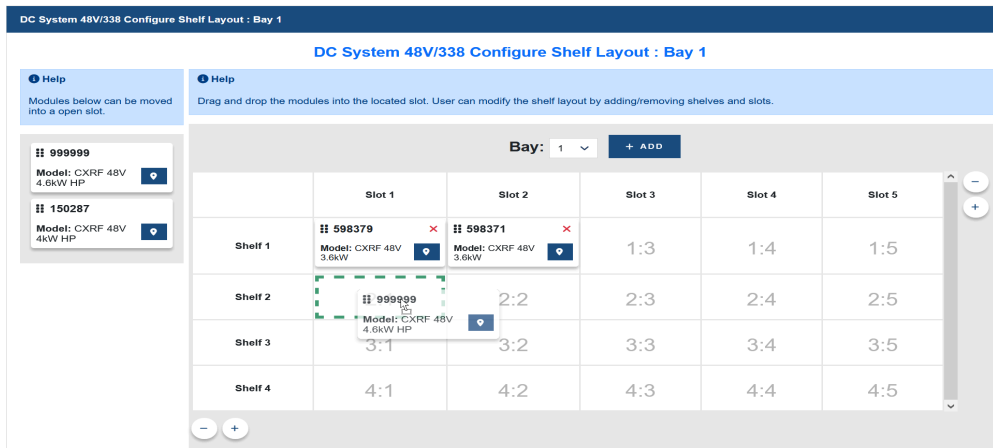

- To remove a module from the layout grid, select the red “X” icon. The module will return to the list of available modules.
- Repeat the steps above until you have mapped all your modules.
- After you have mapped all the modules, go to **Shelf Layout** on the main menu and you will see the completed shelf layout grid.

If you select a module in the layout, you will be taken to the details of the module. In the details page, you will see that the bay ID, shelf ID, and slot ID information is set to where you dropped the module.

4.3.5. Overview of the in-shelf display

In-shelf controllers have a small OLED display. This displays shows 30 characters total (six characters wide, five lines high) and the controller has three navigation buttons and one reset button.

In-shelf display screens

The in-shelf display has three main operating modes: dashboard, menu, and screen saver. After 20 minutes with no activity, the in-shelf controller goes into screen saver mode and the display shuts off. From screen saver mode, press any of the three navigation buttons to re-activate the screen and enter dashboard mode.

In dashboard mode, the in-shelf display shows the key operating parameters of a system. For example, output voltage and load current. If more than one system is defined, you can cycle between systems using the **Forward** and **Back** buttons. With multiple systems, you can specify a default system, which is then displayed first.

To set a default system, from the web interface, go to the **Controller > Settings > User Interface** and select a system from the **In-Shelf Controller Display Preferences** table.

In-shelf display menu

From the OLED display dashboard, use the **Select** button to enter a menu. From the menu, the OLED display lets you execute a set of commands much like the LCD screens on the 2RU controller.

When you enter a menu, the top item is highlighted. To go to another menu scroll through using the **Forward** and **Back** buttons. To execute a highlighted menu item, select the **Select** button.

To exit a menu and return to the main OLED display dashboard, scroll to the **Back** command, and then select the **Select** button. The following figure shows an example of the menu screen. The following table provides a full list of menus available via the in-shelf display.

Table 4-1 In-shelf controller full menu

Menu label	Description
ALCO	Perform the alarm cut-off command.
Rstrt	Perform a restart of the controller.
IPv4	Display the IPv4 address, subnet, and gateway for this controller.
IPv6	Display the IPv6 addresses assigned to this controller.
AutoIP	Set the IP to Automatic (obtained from DHCP server).
RstIP	Reset the IP to Static Default (IP: 10.10.10.201, subnet: 255.255.255.0).
Port	Displays the port number for the controller.
Backup	Backup the controller application and configuration to a file on a USB device.
Resto	Restore the controller application and configuration from a file on a USB device.
Upgra...	Upgrade the controller application from a file on a USB device.
OS Upg	Upgrade the controller's operating system from a file on a USB device.
Info	Display controller information including serial number, part number, software and hardware version.
Rotate	Rotate the in-shelf controller display information by 90 degrees.
Explnv	Export all inventory to USB drive. This is a large file and may take a while to export. The data can be used for analysis in a spreadsheet program.
RemCfg	When Remote Configuration Lockout has been enabled, this menu allows the lockout to be temporarily overridden for a pre-configured amount of time.
Back	Exit the menu and return to the OLED display dashboard.

In-shelf controller buttons

The in-shelf controller can be mounted vertically or horizontally. The contents of the display can be rotated, but the buttons cannot be rotated.

4.4. Email notification

The controller can be configured to send alarm summary emails. In this case the controller is acting as an SMTP client. This section describes the features of and how to set up the controller email client.

For email notifications in a different language, go to **Controller > Settings > User Interface** and set the **LCD Language** in the **LCD Preferences** table to a preferred language. Although this setting is called LCD Language, it serves as the default language for the controller, and will affect the language of email notifications.

Figure 4-24 SMTP client and server default ports

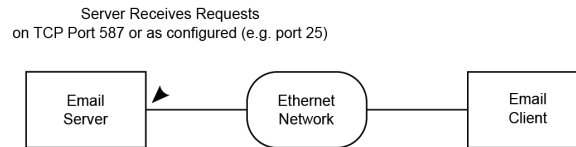

A summary of alarm activities in the controller can be delivered using email. A period of monitoring time is configured, and then all alarms within that period are reported.

This summary is designed to assist decision making when determining the urgency of any action required to resolve issues that may occur in your system.

Table 4-2 Email notification features

Feature	Description
HTML Based Emails	HTML based emails provide better formatting features such as color coding and table alignment.
Multi-level Security	Different security levels are available and automatic detection is executed to support the appropriate level. Direct SSL connection (default port 486) is not currently supported.
Encrypted SMTP Server Password	The password used for authentication on the SMTP server is securely encrypted.
Test Email Capability	A test button is available to send a test email ensuring proper configurations are set for email notifications to reach the appropriate monitors.
Public SMTP Server	We currently support the following public server: Google Gmail: With less secured connection set in the Gmail account. (OAuth2 protocol is not supported. Please refer to Google developer site for more details. https://developers.google.com/identity/protocols/OAuth2)
Private SMTP Server	The controller supports private servers with the following security settings: <ul style="list-style-type: none"> • TLS • Clear text with authentication • Clear text anonymous

Email content

- Subject line with filterable text and alarm counts.
- Static title for filtering.
- Configurable name of the controller.
- Configurable location of the controller which provides a link to open Google Maps showing the location of the controller (Internet connection required).
- Time and date of the notification.
- List of up to ten active alarms sorted by priority with an active alarm count indicator showing total active alarms.
- List of up to ten cleared alarms sorted by priority with a cleared alarm count indicator showing total cleared alarms.

How email notification works

- An alarm activity is the main item that will trigger an email notification. To avoid overwhelming the network, emails are only sent out at the configured interval set in the **Email Destination** table.
- When alarm transitions occur (for example, alarms activating or clearing) a timer starts from the first transition. During this collection period, all alarm transitions are collected for reporting in the email that is sent out at the end of the period. Continued transitions after the email is sent will start another timer for the next email notification.
- Active alarms are reported as a snap shot of all currently active alarms, regardless of when they activated or if they were a part of a previous notification.
- All cleared alarms are collected based on the last occurrence within the collection period. This is to avoid multiple entries of the same alarm in the case the alarm toggled multiple times.

Secured email

Connection to a SMTP server defaults to TLS secured connection on port 587. Checks are done via the controller and if TLS is not supported, proper degradation of security features is done in the following sequence:

1. TLS handshake attempt.
2. Clear-text authentication with username and password.
3. Anonymous clear-text transmission with no authentication.

The checks are done by following SMTP protocol for SMTP server commands and responses. Please see SMTP protocol standards for more details.

Table 4-3 Email configuration

Configuration	Description
Enable	Email notification defaults to inactive. Enabling allows email notifications to go out when all configuration information is set correctly.
SMTP Server Address	A DNS name or an IPv4 or IPv6 address will work in providing a target location of the email server.
Port	Default port is 587
Domain	This is a DNS formatted string (words separated by '.') used for identifying the client to the SMTP server. Required for most public SMTP servers like Google.
SMTP User Name	The username used for authentication to the server to access SMTP resources.
SMTP Password	The password used for authentication to the server to access SMTP resources. Set this value by using the Set SMTP Server Password button. You can clear the configured password by using the Clear Server Password button.
From	The From field is used as the source of the email and is usually the same as the Username provided to authenticate the client to the SMTP server. For example, Gmail requires this value to be the email address of the account in use.
To	The To field is for the destination or receiver of the email notification. This field allows multiple email address entries separated by commas.

4.5. Setup SNMP communication

SNMP is a standard protocol or language that Network Management Systems (NMS or SNMP manager) use to control network devices and report information. A typical SNMP system is often represented as one SNMP manager collecting data from several SNMP agents or devices.

The controller acts as an agent or device in an SNMP system. This section of the manual describes how to add a new agent (the controller) to an existing SNMP system. It does not cover how to set up an SNMP manager nor does it explain how to correctly set up an SNMP system. Those topics are specific to the SNMP management software chosen which will have its own documentation.

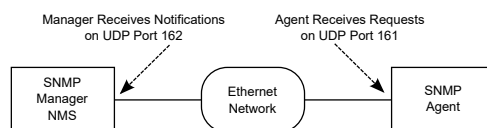
Figure 4-25 SNMP manager and agent default ports

There are two main steps required to add a new agent to your SNMP system:

- Configure the agent with the IP address of your SNMP manager (tell the agent to send information to the manager).
- Compile the agent's Management Information Bases (MIBs) into the manager (tell the manager how to interpret information sent by the agent).

Configure an IP address to receive notifications

Configuring an IP address for notifications is referred to as *Subscribing to Notification Services*. Up to ten IP addresses can be configured. SNMP monitoring systems need to compile and install the ALPHA-NOTIFICATION-MIB. Please refer to the user guide of the SNMP manager for this process.

For each of the ten SNMP notifications addresses, the user can select the address and select the **GO TO** button to see more details about that particular monitoring destination, and to edit details.



Notice: For detailed information on using SNMP, see the *SNMP Integrator Guide (User Guide ID: 0350099-J0)* on the Alpha® website, www.alpha.ca.

4.6. Setting up Modbus communication

The controller can act as a Modbus server (agent) in a Modbus system. This section describes how to enable the Modbus server on the controller. It does not cover how to set up a Modbus client nor does it explain how to correctly set up a Modbus monitoring system. Those topics are specific to the Modbus client software chosen which will have its own documentation.

Figure 4-26 Default ports: Modbus client (master) and server (agent)

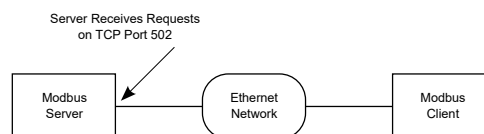

To setup Modbus TCP/IP on the controller, you need to enable the Modbus server via the web interface:

1. Go to **Controller > Communication > Modbus**.
2. In the **Configuration** table, enable the Modbus Agent.
3. Select the **EDIT** button on the **Internet Protocol** line, and then select the internet protocol to be used.
4. Select the **EDIT** button on the **Byte Order** line, and then select the byte order.
5. Limited Data Set Device IDs are normally left as the default values.



Notice: For detailed information on using Modbus, download the **Modbus Integrator Guide (User Guide ID: 0350114-J0)** on the Alpha® website, www.alpha.ca.

4.7. Setup syslog communication

Syslog overview

Syslog (System Logging Protocol) is a communication protocol which is used to send system log or event messages to a server that supports Syslog. This protocol is a Simplex Communication Protocol meaning information only gets sent in one direction. The controller, acting as an agent, has the capability to send event log and module log messages to a configured Syslog server.

4.7.1. Syslog agent configuration

To setup the **Syslog Agent** on the controller:

1. Go to **Controller > Communication > Syslog**.
2. In the **Configuration** table, select the **EDIT** button and then select **Enable** from the dropdown menu.
3. If the **Facility Value** is different that Local 0 (default), set the value using the **EDIT** button to the expected value for the Syslog server.
4. Follow the Syslog destination configuration section in this manual to configure specific Syslog servers

4.7.2. Syslog destination configuration

On the controller, a Syslog server is considered a destination. The controller can be configured for up to 10 receiving destinations meaning 10 different Syslog servers can receive controller curated Syslog messages. Any messages generated in the **Logs > Events & Alerts** page of the controller will be sent to a Syslog destination. Be sure to enable the Syslog agent, detailed in Syslog agent configuration section of this manual, prior to starting this section otherwise no messages will be received for any Syslog server.

1. Go to **Controller > Communication > Syslog**.
2. In the **Syslog Destinations** table, select the **GO TO** button for one destination.
3. For this single destination, using the **EDIT** button for each configuration, configure the Server IP Address, Server Port, and RFC Version to start receiving Syslog messages.

4.7.3. Syslog message format

A controller Syslog message will contain a priority, some header data, and the message.

An example message using Linux rSyslog:

```
Aug 08 8:58:00, 192.168.0.99, CXCHP[v8.00], ControllerEvent, [Source]: Web User, [Name]: Logon, [Value]: admin
```



Notice: The message presented is not the entire message displayed and the timestamp is formatted via rSyslog on Linux. It is to be used as a reference for the information detailed below.

Using the Syslog message format, the controller will curate a message with the following:

1. In Syslog message format, the AppName is the CXCHP[Version].
2. In Syslog message format, the MsgId are the specific types of events generated by the controller. These events categories are: *ConfigurationEvent*, *ControllerEvent*, *AlarmEvent*, and *ModuleEvent*. To find these generated events on the controller web interface, go to **Logs > Events & Alerts**.
 - a. A *ConfigurationEvent* can be generated when configuration on the controller changes.
 - b. A *ControllerEvent* can be generated when any action, state transitions, or any event that does not fall into the other three categories.
 - c. An *AlarmEvent* can be generated when any alarm is activated or deactivated.
 - d. A *ModuleEvent* can be generated if transitions occur on a module.
3. All event types will always have a severity level of Information besides *AlarmEvent*.
4. An *AlarmEvent* has a severity level that can change. This change is based on the specific alarms priority configuration on the controller. The alarm priorities on the controller are mapped to the severities of Syslog. The mappings can be found in the following table.
5. In the Syslog message format, the controller event message will have the format of "[Source]: Source of the Event, [Name]: Name of the Event, [Value]: Value of the Event".

Table 4-4 Controller alarm priorities to Syslog severities mapping table

Controller priority level	Syslog severity level (name)	Syslog severity level (#)
Critical	Critical	2
Major	Error	3
Minor	Warning	4
Warning	Notice	5

5. DC power systems

This section provides a brief overview of the components and functions within a typical DC power system. A basic power system usually consists of rectifiers and batteries, but can also include other components.

5.1. Guidelines for commissioning the DC system

The following section contains basic guidelines for commissioning a DC power system. Overall system commissioning consists of four parts: power system inspection, battery inspection, commissioning the system, and testing the system. Commissioning should only be conducted by a qualified technician. For more detailed information refer to the relevant system manual for your specific system.

Perform an inspection of the power system to confirm that the mechanical and electrical requirements and parameters are within specification. Pay special attention to the battery to ensure it is installed safely and correctly, and that the battery terminals are torqued to specification.

1. Make sure all power to the system is off.
Are all batteries disconnected, rectifier modules are removed, fuses pulled and circuit breakers turned off?
2. Make sure the battery polarity is correct. Use a voltmeter if necessary to confirm.
3. Install one rectifier.
4. Turn on the AC to the rectifier and allow it to start up.
Verify that the system starts up, and the controller turns on. Did the rectifier turn on? AC and DC lights on?



Notice: *With no load and batteries disconnected, the rectifier may have a fail alert. This should go away when load is connected.*

5. Confirm the battery settings on the controller: capacity, charge limit, the Peukert exponent. If there is no means of disconnecting the battery, then the rectifier output voltage should be reduced by using the controller to match the rectifier voltage to the battery voltage to avoid sparks.
6. Check that the battery polarity is correct and turn on the breakers, fuse or circuit breakers for the batteries.
7. Follow the initial battery charge procedure as indicated in the manufacturer's instructions.

The controller and rectifiers are operating normally. There may or may not be active alarms depending on system configuration.

Perform commissioning tests to confirm that the system is operating properly. Specific tests to perform will depend on the system configuration but may include:

- Correct AC input voltage and DC output voltage
- Battery test
- Relay test

- Battery disconnect operation
- Alarm test

5.1.1. The battery mode

The **Battery Mode** value, as shown in top section of the web interface or in the system **Status** page, indicates the state of the battery in the system.

In a system with a fully charged battery, the **Battery Mode** will be **Float** which indicates the battery is floating.

In a system that is charging, the **Battery Mode** will be **Charging**. The adjacent value either show **Bulk** (battery is charging at constant current) or **Absorption** (battery is in the absorption phase of charging).

In a system that is discharging the **Battery Mode** will either be **Discharging** (AC mains has failed) or **Test Discharging** (battery test in progress).

The **Battery Mode** may also be **No Battery** (no battery in the system), **Disconnected** (battery appears disconnected) or **Unknown**. When it is **Unknown** then the controller is busy trying to determine the state of the battery. If this value persists for more than a minute or so, it may indicate that one or more of the following may not be properly configured:

- Load current
- Battery current
- Battery capacity
- System voltage
- Battery voltage (it is recommend that system voltage and battery voltage to be configured to read the same)

5.2. DC system functions

5.2.1. Modules, inventory, and system functions

To set up a system on the controller, you need to work with modules, inventory, and system functions. This section explains these terms which will help you to navigate the controller menu and answer questions such as:

- Why are rectifiers in both the **Modules**, and in the **Inventory** menus, but ADIO modules are only in the **Modules** menu?
- Why is temperature compensation in the **Systems > DC System > System Functions** menu, and not under the **Systems > DC System > Inventory > Battery** menu?

Modules

A module is a device that communicates information. Most modules in a controller system will be CAN devices such as rectifiers, converters, inverters, and ADIO modules. Future releases, may have modules such as Ethernet and USB-serial connected modules.

Since the controller can communicate with modules, each module in the system should also have a **Communications Lost** alarm. Most modules are replaceable, because of this there are functions within the system to remove old modules and create new ones. Some modules also have the ability to download reports and diagnostic information via the controller.

Inventory

An inventory item is an item that is directly involved in the flow of power through the system. For example, a rectifier is an inventory item but a controller or an ADIO module is not. Other examples of system inventory are: AC source, rectifier, load, battery, disconnect, shunt, DCCT, breaker, and power meter. Setting up the inventory of a system focuses on the monitoring, not the control of the system.

You can set monitoring in one of three ways:

1. If the inventory item is also a module, you can communicate with it directly, such as with rectifiers.
2. If the inventory can be measured or controlled via an ADIO module, then you can map the inventory to read data through the ADIO module, such as with shunts, batteries, current transducers, and disconnects.
3. If the inventory item's values can be inferred through a calculation, then you can map the inventory to use that calculation such as with AC sources and DC loads.

System functions

System functions are the major features of the system. Some examples are:

- Battery charging
- Battery runtime estimation
- Charge current control
- Voltage regulation
- Temperature compensation

Once the inventory is in place to monitor the system, you can configure and test the system functions to ensure that the system is working as intended.

5.2.2. Mixed rectifier system

You can add any rectifier to the DC system that has the appropriate DC bus voltage. Some of the **System Functions** assume that the controlled rectifiers and managed batteries are the only source of power on the DC bus. Those **System Functions** work best with either a single rectifier model or models that have been designed to work together such as, the Cordex® 1.8 kW and the Cordex® HP 2.0 kW rectifiers, or the Cordex® 3.6 kW and the Cordex® HP 4.0 kW rectifiers.

Mixing of other rectifier types is not recommended. If you need to mix other sizes and types of rectifiers you may need to turn off some of the **System Functions** for the DC System. See your system manual or contact Technical Support if you encounter this situation and do not have instructions on how to set up the **System Functions**.

5.2.3. Battery charging

The controller applies a typical three-stage charging cycle including *Bulk Charging*, *Absorption Charging*, and *Conditioning* which is sometimes called float charging.

Figure 5-1 Three-stage charging cycle

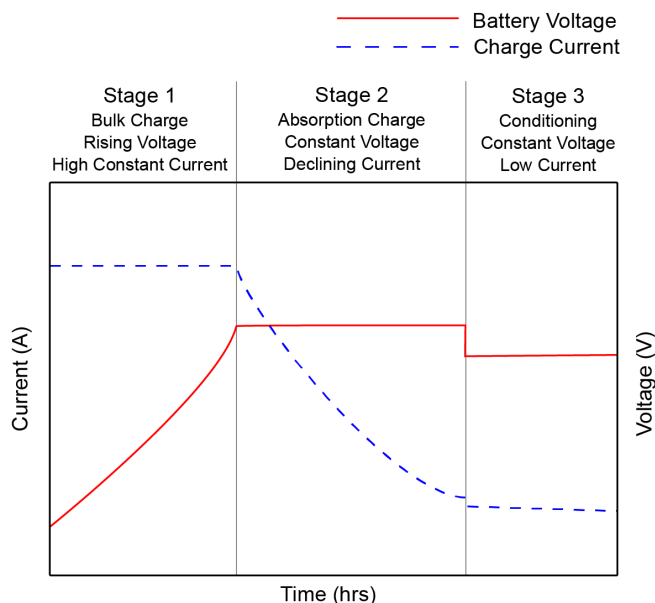

Bulk charging

After the bulk charging stage, the battery should be in a 70 to 90 percent state of charge. On the **Systems > DC System > System Functions > Charging** page, in the **Primary Charge Current Control** table, you can enable and disable charge current control and set the charge current limit (C/X) in hours.

CAUTION: If you do not set a charge current limit, the battery may be charged at a much higher rate than is recommended by the battery manufacturer.

Absorption charging

After the absorption charging stage, the battery should be in a 95 to 98 percent state of charge. On the **Systems > DC System > System Functions > Charging** page, on the **Elevated Absorption Charging Status** table, you have the option to charge the battery at a voltage higher than the float voltage. The higher voltage is used to speed up the absorption charging stage after a prolonged AC power failure.

Conditioning - float

The conditioning or float charging stage brings the batteries to 100 percent state of charge and maintains it there. When the system is in the conditioning stage it is usually at the **Float Voltage**. When the system is in conditioning-float, a higher **Equalize Voltage** or **Boost Voltage** can be applied from the **Systems > DC System > System Functions > Equalize & Boost** menu.

Conditioning - equalization

When a string of battery cells or blocks are charged, a single charge current is applied on the group. If the voltages of the cells or blocks begin to differ, the charge imbalance can lead to battery failure. Applying a higher **Equalize Voltage** to a fully charged battery string subjects the stronger cells or blocks to overcharge but this also allows the weaker cells or blocks to regain their full charge. When the voltage is returned to the **Float Voltage**, the stronger cells shed their overcharge and the battery string should be more balanced or equalized.

Applying an Equalize Voltage (an overcharge) to a fully charged battery can also be used to reverse sulfation.



CAUTION: *Applying an overcharge to a battery string also has negative effects on the batteries. See the battery manufacturer's guide to determine whether an equalization voltage should be used at all. If so, what the voltage and the duration should be, and how frequently an equalization charge should be applied.*

Conditioning - boost

The purpose of boost is similar to equalize - to equalize cells or reverse sulfation. Boost voltage is usually a higher voltage than equalize. In fact it can be too high for the load and therefore require the presence of dropping diodes to be switched into the circuit between the rectifiers and the load to prevent damage to the load. Before boost can be activated, the dropping diodes must be switched into the circuit.

5.2.4. Battery temperature compensation

Temperature compensation (Temp Comp) is used to prolong battery life and help prevent thermal runaway. When battery temperature compensation is enabled, the controller uses the battery temperature to calculate an offset which is applied to the battery voltage.

A typical temperature compensation curve for a 48 volt battery system is shown in the following figure.

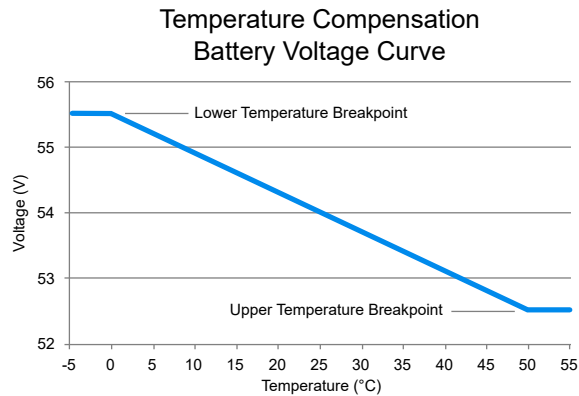
Figure 5-2 Temperature compensation voltage graph

Battery performance and life expectancy are directly related to the battery ambient temperature. The optimum operating temperature for battery operation is typically 25°C (77°F). Above this temperature battery life may be reduced and below this temperature battery performance may be reduced.

Thermal runaway occurs if the internal temperature rises due to overcharge, high ambient temperature or internal fault. Temp Comp automatically adjusts the float voltage as the battery temperature changes to protect the battery from thermal runaway.

The Temp Comp function adjusts the system voltage every two seconds, as the temperature changes, and provides for a maximum voltage change of 0.2 V over this interval. Temp Comp occurs at standard rates commonly referred to as slope-compensation settings.

The slope of the Temp Comp curve in either mV/°F/Cell or mV/°C/Cell can be set via the **Systems > DC System > System Functions > Temperature Compensation** menu in the **Configuration** table. The value is set based on the battery manufacturer's information.

Since a battery can have multiple temperature sensors, temperature compensation uses the average of the temperature readings to determine the battery temperature on which to adjust the battery voltage. The average is used as long as all the temperature readings are within 5°C (9°F) of each other. When a temperature reading rises, perhaps due to local heating or thermal runaway, and reaches a point when the highest temperature reading is 5°C (9°F) greater than the lowest temperature reading, then temperature compensation will use the highest temperature reading to determine the compensated battery voltage. This will result in a lower battery voltage and reduce the risk of thermal runaway.

If one or more battery temperature probes appear to be disconnected or broken, then the Temp Comp function calculates the enabled setpoints as if the temperature reached the **Upper Temperature Breakpoint**. This is the safest option in case the failed sensor happened to be the one with the highest temperature reading.

5.2.5. Battery runtime and health estimation

Battery Estimation can be enabled via the **Systems > DC System > System Functions > Battery Runtime & Health** menu in the **Configuration** table. When enabled, the controller calculates an

Estimated State of Charge (SOC), and an **Estimated Battery Runtime (RTR)** remaining at all times. It is not always practical to estimate these values. For example, if the system goes into a charging stage immediately after a restart, there is no way to estimate the SOC or RTR.

The accuracy of the estimated battery health improves as the battery undergoes more discharge cycles and it also improves with deeper discharges.

If a battery discharge occurs that goes below an SOC value of 80 percent, then the **Battery Runtime & Health Estimation** function creates a **Last Battery Discharge Summary**, a **Last Battery Recharge Summary** and recalculates the **Estimated Battery Health**. If estimated battery health is less than 80 percent then that battery is normally due to be replaced.

5.2.6. Low voltage disconnect operation

Whenever the system parameters requires the LVD to be activated, a 60 second countdown and audible warning begins. When the countdown reaches zero, the LVD is activated.

During the countdown, a command in the disconnect menu can be pressed to inhibit LVD activation. When the disconnect first changes to **Pending**, every user logged into the system will receive notification that the disconnect is about to activate, and the option to inhibit it. To release the inhibit, you must activate the release command for each LVD.

There are three types of disconnects: “legacy” disconnect, general purpose disconnect, and battery disconnect with latching contactor.

Legacy disconnect

The legacy disconnect is the first disconnect available on the controller. It offers the ability to disconnect based on voltage, time elapsed since AC fail, and the state of charge of the battery.

General purpose disconnect

The general purpose disconnect is best suited for use as a load shedding disconnect. It can be configured to disconnect based on voltage, or up to three customizable disconnect conditions. There are three customizable reconnect conditions in addition to the usual voltage reconnect threshold.

When using the optional disconnect, note the following conditions:

- The voltage must be less than the disconnect threshold **or**
- One or more optional disconnect conditions are true **and**
- All optional reconnects must be unknown or false
- If the option to disallow disconnect during battery test is true and battery test is active, the disconnect will not activate until battery test is no longer active or this option is disabled.

When using the optional reconnect, note the following conditions:

- The voltage must be greater than the connect threshold **or**
- One or more optional reconnect conditions are true **and**
- All optional disconnect conditions must be unknown or false
- If the option to require AC for reconnect is enabled and AC input is not present no reconnect will occur until AC returns or this option is disabled.

To better support use as a load shedding disconnect there are three configuration parameters that may be used to further customize the behavior:

1. **Allow disconnect during battery test:** By default this is set to **No** but may be set to **Yes**.
Example: using the battery test to observe and measure the runtime available to critical loads after less important loads are disconnected.
2. **Require AC info for reconnect:** By default this is set to **Yes** but may be set to **No**. Example: if there are additional DC sources (like solar panels or a DC generator) on the voltage bus that are capable of supporting the loads even when AC is lost.
3. **Required time to stay disconnected:** By default this is set to 0 seconds. It may be set to a non-zero number in to ensure that a load is fully powered off before reconnecting. Some loads may not start up correctly unless they are fully powered off first.

Battery disconnect with latching contactor

A battery disconnect with a latching contactor can be used for disconnecting based on voltage. External to software, this type of contactor requires a latching contactor interface which is used with a traditional ADIO module.

A battery disconnect with latching contactor can be created using the **Create Disconnect** wizard found at **Systems > DC System > Inventory > Disconnects**. After creation, the disconnect will appear in the **Disconnects** table, use the **GO TO** button in the table row to configure the battery disconnect with latching contactor.

Operation of the battery disconnect with latching contactor

The Battery Disconnect with Latching Contactor operates differently than a standard non-latching contactor. The controller will energize the associated ADIO module relay (for example, Relay to Open or Relay to Close, depending on the desired contactor state) for approximately four seconds and then de-energize the ADIO module relay. The brief energization of the ADIO module relay provides a pulse of current to open or close the latching contactor. The latching contactor has an internal magnet to keep it open or closed after the pulse has been applied and does not continuously draw power unlike standard contactors.

Contactor state source

The **Contactor State Source** is used to detect the contactor physical state which could be Open or Closed. If this is set, the controller will automatically attempt to fix the contactor state if an incorrect state is detected. If the state does not automatically adjust after a few retries then the **Contactor State Error**

Alarm will trigger indicating the position of the contactor is not in its expected state. If this source is not set, the controller will not attempt to close or open the contactor as the state is unknown.

Contactor retry countdown

The **Contactor Retry Countdown** is found in the **Status** table. The contactor retry countdown will automatically start counting down after three retries. After the retry countdown reaches 0, the controller will automatically attempt to retry closing or opening the contactor three times. If the expected state is not reached, the contactor retry countdown will start over.

Test disconnect open button

To test the contactor, there is a **Test Disconnect Open** button located in the **Status** table. A test can only be initiated if the disconnect **State**, found in the **Status** table, is **Inactive** (contactor closed).

The **Test Disconnect Open** button will open the contactor. The contactor will remain open for 60 seconds, then close automatically.

5.2.7. Battery test

A battery test is used to update the **Estimated Battery Health** of a lead acid battery. The settings for this feature can be found in the **Systems > DC System > System Functions > Battery Test** menu. The **Estimated Battery Health** will be updated on the **Systems > DC System > System Functions > Battery Runtime & Health** page.

Definitions

- **Battery test termination voltage:** The voltage threshold at which the test normally ends.
- **Battery test timeout:** The maximum time the test can run before it is stopped.
- **Battery test termination on SOC:** Enable or disable the Battery Test Termination SOC threshold to terminate a battery test.
- **Battery test termination SOC:** The State of Charge (SOC) threshold at which the test normally ends.
- **Battery test alarm:** The battery test is active.

Using the test discharge (TD) mode

If the test is started when the battery is fully charged, the results of the battery capacity estimate will be more accurate. Use charge current control to limit the battery recharge current to the battery manufacturer's specified maximum value.

During a test, the **Estimated State of Charge** and **Estimated Battery Runtime** hours can be viewed via the **Systems > DC System > Status** menu in the **Battery** table or the **Systems > DC System > System Functions > Battery Runtime & Health** menu in the **Status** table.

Test discharge initiation

When the test begins, an entry is made in the event log. If the **Battery Test Alarm** has been enabled, it provides a warning to indicate that a battery test is in progress. The output voltage of the rectifiers is set to the Battery Test Termination Voltage to allow the battery to discharge. Battery Mode changes to Test Discharge when a battery test is started.

Test discharge mode runs for the period set as timeout or until the battery test termination voltage is reached or the battery test termination SOC is reached (if enabled).

The rectifiers are periodically scanned to ensure that they do not begin sourcing current. If so then the test is stopped and the battery is recharged.

The rectifier float voltage is reset to the setting that is stored in the system controller. When the system voltage reaches the end (termination) voltage or a timeout occurs, the system controller will command the rectifiers to turn on and enter FL mode.

Activity during test discharge mode

Temperature compensation features are suspended during a battery test. When the battery is discharging, the battery test alarm is active. Battery state of health estimation begins at three percent of DOD, but is not displayed unless DOD > 20 percent; the point at which reasonable accuracy can be assured.

AC failure during test discharge mode

If the AC fails during a battery test, the test is aborted. This places the rectifiers into a state that enables them to resume providing power to the load when AC returns. If the runtime is being displayed, it continues to update.

Addition of rectifiers during test discharge mode

If rectifiers are added to the system when a battery test is active, they are placed into the same state as the current system rectifiers. They are either: placed into battery test state or set to the same voltage as rectifiers already in the system.

Conditions to watch for during test discharge mode

If the voltage drops below 46 volts before or when three percent depth of discharge is reached, the test is aborted and the battery health is set to zero percent (resulting in a *Battery Health Low* alarm). This provides an indication that the battery is very weak. Battery state of health must be manually reset to 100 percent before the next battery test is started, so that the battery monitor can properly estimate the battery health. If rectifiers are sourcing current during the test, and the battery ceases discharging, the test is aborted.

Canceling test discharge mode

Test Discharge mode can be canceled by either changing the mode to Float or stopping the test manually. To stop the battery test manually go to **Systems > DC System > System Functions > Battery Test** and select the **Stop Manual Battery Test** button in the **Status** table.

Battery discharge test completion

Once the battery begins to charge, the recharge cycle begins. Live battery recharge information is available at **Systems > DC Systems > System Functions > Battery Runtime & Health** menu in the **Status** table. The test is considered complete once the battery begins to charge. This is due to either, the test ending from timeout, the system reaching the termination voltage or from an abort condition.

5.2.8. Power save

When using **Power Save** we recommend the following:

- That the **Power Save** feature only be used on systems with a battery.
- If a system supports 120 to 240 Vac input operation and if operating at less than 208 Vac - do not use **Power Save**.
- The current and power limit settings in **Systems > DC System > Inventory > Rectifiers > Configuration** menu in the **Configuration** table should be set to 100% when using **Power Save**.

The **Power Save** feature is designed to improve the efficiency of the system, by optimizing the output power of the rectifiers. Rectifiers that are either loaded too light or too heavy generally have lower efficiency.

Power Save analyzes the system power requirements, as well as available rectifier capacity, determining the optimum loading. Based on the system information the controller then takes rectifiers into or out of standby to achieve maximum rectifier efficiency. Rectifiers in standby do not supply to the load or to battery charging. **Power Save** periodically cycles these rectifiers to ensure they contribute evenly to supplying the load. This balances rectifier operation and maximizes rectifier lifetime.

When active, **Power Save** relies on the battery to briefly take up some of the load current during operation. If there are modules in standby and the load increases, rectifiers supplying power will momentarily have reduced capacity to supply the load. At that point the battery supplies the extra capacity required. **Power Save** detects this and will bring one or more rectifiers out of standby so that the load is fully supplied by the rectifiers.

Power Save has three main tables, **Status**, **Configuration**, and **Modules**. The **Status** table has a **Test Rotation Now** button which can be used to immediately advance the rotation of the rectifiers. Regular scheduled rotation will still occur according to the **Module Rotates In time** settings.

To view these tables go to **Systems > DC System > System Functions > Power Save**.

Configuration table

The **Configuration** table has the following fields:

- **Power Save:** Enable or disable the power save feature on a system.
- **Module Power for Maximum Efficiency:** Provides a percentage at which the module should be loaded to achieve maximum efficiency. **Power Save** works to get as close to this value as possible. Refer to the module's installation manual to get information for best performance. If you don't have this information, use the default value based on the rectifiers used.
- **Rotate One Module Every:** A length of time in days. After the configured number of days, the module that has been in standby longest will be turned on, the module that has been on the longest will be turned off. Module rotation occurs at 3am.

Status table

The **Status** table displays which values **Power Save** calculates. These include the following fields:

- **Power Save:** Provides the general status which may be active, disabled, insufficient redundancy or invalid data suspended. **Power Save** cannot operate if in a battery test, if AC has failed or if any required data is unknown.
- **Average Power:** Provides the average module output power computed for the system. **Power Save** will try to get this value as close as possible to the **Module Power for Maximum Efficiency** (set in the **Configuration** table). For example: if the efficiency target is 80 percent, and the average power is 72 percent and turning off a rectifier would make the average power 83 percent, then **Power Save** will turn off a rectifier to get closer to the efficiency target.
- **# Modules Supplying Power:** The number of modules presently supplying power (or capable of supplying power). Modules that are failed, comms lost or have derated output for any reason are not included in this count.
- **#Modules in Standby:** The number of modules presently not supplying power but can be turned on to supply more power as needed.
- **Module Rotates In:** Provides how many hours left until the next module rotation (always occurs at 3am).
- **Estimated Time to Rotate All Modules:** Provides the estimated number of days until all modules in the system will be rotated. This value changes depending on number of rectifiers and rotation period.
- **Estimated Required Capacity:** Provides the capacity required to supply the load and charge the battery. For example, if your load is 100 A and your battery charge current limit is 10 A, this value would be 110 A.
- **Estimated Available Capacity:** Provides the estimated available capacity of all modules that are **Supplying Power** (modules **In Standby** are not included).
- **Estimated Redundant Capacity:** Provides the estimated extra capacity of all modules that are supplying power in the system. In a system operating in **Float** mode, some modules are **In Standby**, and some are **Supplying Power**. The modules **Supplying Power** may be loaded at

80 percent. The remaining 20 percent is considered redundant capacity. This represents rectifier capacity that is immediately available should a rectifier fail. This number can be increased by lowering the **Module Power for Maximum Efficiency** to cause more rectifiers to turn on – it is up to the user to balance the requirement for redundancy versus operating efficiency.

- **Estimated Standby Capacity:** The estimated amount of capacity for modules that are in standby.

Modules table

The **Modules** table displays the **Power Save** status of all the modules in the system including: serial number, mode, and **Hours Supplying Power, In Standby**.

Hours Supplying Power and **Hours In Standby** is the time a rectifier spent in those modes.

5.3. Create a DC system manually

On a controller, if there is no power system defined, you can create the inventory items needed to monitor and control a DC system. There are four steps to creating a new DC system.

1. Verify that the ADIO module sensors you are using to monitor the system are working correctly, and document the purpose of each sensor and relay used.
2. Create the DC system and other inventory items, and then configure the inventory to use the ADIO module sensors to monitor the system.
3. Configure each of the system functions to correctly control the DC system and manage the battery.
4. Adjust thresholds, enable and disable alarms, and set up any remote alarm reporting using alarm relays or SNMP notifications.

This section provides the first steps of how to set up a 48 Vdc system. For this example, the system is set up as shown in the following figure.

Figure 5-3 Example of a DC system

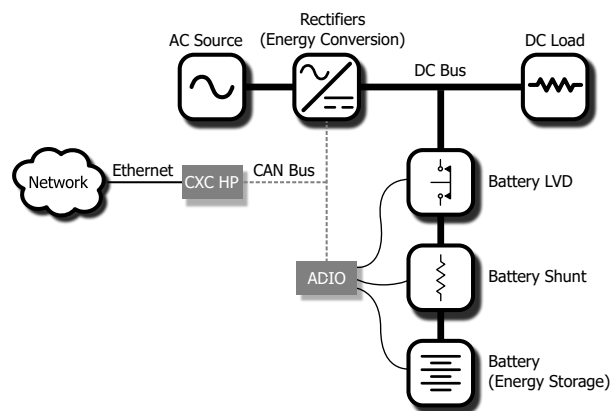

5.3.1. Quick reference for configuring a DC system

The following figure shows the key configuration settings for a DC system that should be set or checked so that the system operates correctly.

There are many optional and alarm reporting settings that can also be configured.

Figure 5-4 Quick reference for configuring a DC system

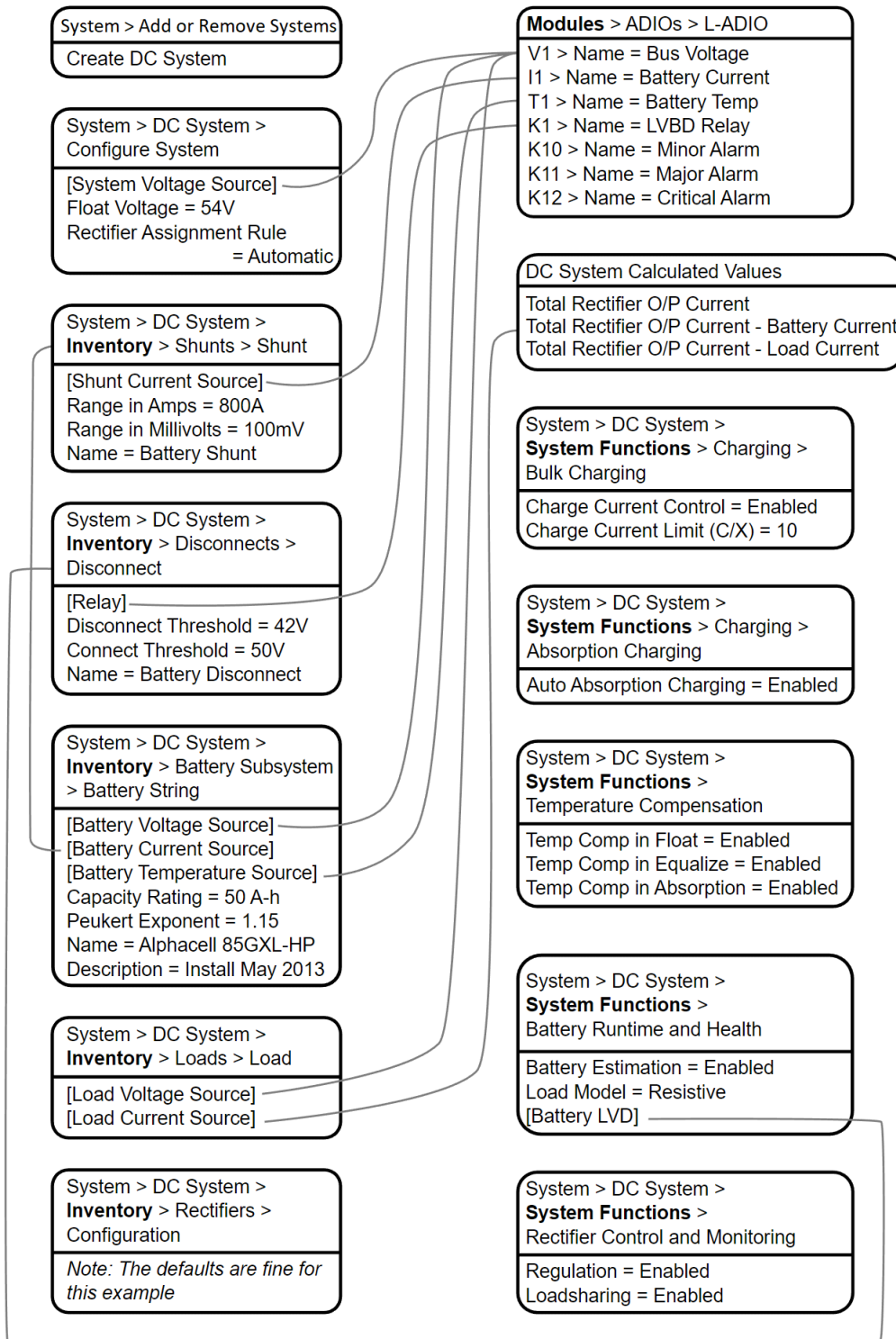

5.3.2. Create a DC system

There is no DC power system on a new controller. Creating a DC system is done using the **Create System** wizard. In the current release, only a single DC system is supported, so if a system already exists on the controller, the option to create a new DC system will not be available.

You can also import a configuration file containing a DC system from another controller.

A new power system can be created via the **Systems > Add or Remove Systems** menu from either the LCD or the web interface. Both have wizard assistance to help step you through the process to create the new system. You can create either a 48 V system or a 24 V system. Once the system is created, an associated load, battery, disconnect, and shunt is also created.

The DC system will also be created with a reasonable set of defaults and associated alarms. The only value which is mandatory to configure after system creation, is the **System Voltage Source**, which can be set to any voltage input. It is recommended that this be set to the same input as the **Battery Voltage** input. All other items, such as Name, Description, System Number, and Serial Number are optional and can be used to describe and organize your system.

You can configure the alarms associated with the system. You can enable or disable the alarms, change the priority, map relays to the alarms, and where applicable, modify the thresholds.

To create a DC system:

1. Go to **Systems > Add or Remove Systems**. Select the **Create System** button to launch the wizard.
2. Select **DC System** from the dropdown menu.
3. From the results page, select the **Configure DC System** wizard to be guided through system configuration or follow the instructions that follow.
4. Once configured, the **Results** page will give additional guidance on the next steps. If a battery was added during the wizard, a placeholder will be added for this battery. On the **Results** page, the battery string configuration wizard can be launched which allows for configuration of a single battery string. If additional battery strings are required then they will have to be created by navigating to the newly created DC System battery page.

On the **Results** page the wizard provides information on what else needs to be done to ensure the system functions as expected. Any lines coded blue denote action that must be taken, such as in the above example, the **Configure Shunt** and **Disconnect** buttons. The gray coded lines indicate actions recommended, such as in the above example, the **Confirm Load** and **Battery String** buttons. If the item was configured correctly it will display with the line green, meaning no action is required.

5.3.2.1. Create a system from a configuration file

A system can be created by importing from a configuration file. See the *Importing a system* section for more information.

5.3.3. Configure basic DC system settings

The **Configure System** page has three tables (**Configuration**, **System Properties**, and **Alarms**) with some basic settings that must be configured.

To configure basic DC system settings (from the main dashboard):

1. Go to **Systems > DC System > Configure System**.
2. In the **Configuration** table:
 - a. Set the system name, description, number, and serial number.
 - b. Set the float voltage setting. This is the desired output voltage of the rectifiers when the system is in float mode.
 - c. Set the system voltage source, which is the voltage used to control the system. This is the input of the ADIO module that measures system output voltage, and is usually the same input as the battery voltage.
3. In the **Alarms** table, configure the related alarms.

5.3.4. Configure dynamic thresholds for output voltage alarms

Both the High and Low Output Voltage alarms can use a dynamically adjusted threshold. This Adjusted Limit is calculated by adding the difference between the Voltage Regulation Setpoint and the Float Voltage to the configured Limit. To use dynamically adjusted thresholds for an **Output voltage alarm**:

1. Go to **Systems > DC System > Configure System**.
2. In the **Alarms** table, select the **GO TO** button for the **Output Voltage** alarm to configure.
3. Use the dropdown menu to set the Absolute or Adjusted field to **Adjusted**.

5.3.5. Configure the rectifiers

These are settings that include start delay, safe mode voltage, or over-voltage protection threshold.



Notice: *The Safe Voltage is the voltage that the rectifiers default to if they lose communication with the controller. This feature has a time delay that varies according to rectifier. Most rectifiers revert to Safe Mode after five minutes. Check the rectifier manual for a list of the default parameters.*

Rectifier output voltage is configured from the **Systems > DC System > Configure System** menu.

To configure the rectifiers:

1. Go to **Systems > DC System > Inventory > Rectifiers > Configuration**.
2. Set up your rectifier group configuration settings. These include, start delay, safe mode voltage, or over voltage protection threshold.

You can configure the group settings, using information in the following table.

5.3.5.1. Rectifier configuration guidelines

The following are guidelines for setting rectifier configuration. Some or all may apply.

Over Voltage Protection Threshold	Set this value as far above equalize voltage or boost voltage as needed. For a 48 V system, the usual value is 60 V. The actual upper limit of this setting depends on the rectifier model. If the Rectifier Configuration Error alarm is active, it usually means the OVP threshold is too high or too close to the equalize, boost or float voltage setting. It is necessary to have at least 1 V (for 48 V system) difference between float, equalize and OVP settings.
System Start Delay	Set this value to delay the start up of all rectifiers when AC returns to give other AC equipment on site a chance to start up first.
Module Start Delay	Set this value to apply a staggered start delay to individual rectifiers. This helps limit AC inrush current and gives the controller time to engage charge current control, if enabled, to prevent a battery breaker or fuse from opening. Each rectifier is assigned a module start delay that is a multiple of the configuration value. If the value exceeds 250s, the value starts again at the lowest multiple. For example, if the module start delay is 60s and there are eight rectifiers in the system, the start delays assigned to the rectifiers will be: 1s, 60s, 120s, 180s, 240s, 1s, 60s, 120s. This means that three rectifiers will be assigned the same 1s, 60s, and 120s delays.
Current Limit/Power Limit	Set one of these values (not both) to limit the output current of the rectifier. This is normally only done if the site has undersized AC breakers or is running on an undersized AC generator. These values must only be set while in float mode. Setting them when the battery is bulk charging may result in too much current to the battery.
Fast Soft Start	Set this to enabled if the system has no batteries and the load does not turn on when AC returns.
CL/PL alert	This is usually disabled when the system has batteries to avoid a current limit or power limit alarm during battery charging.
Ramp Test	This is normally enabled to detect if a rectifier has been disconnected from the load. When enabled and if the rectifier is sourcing less than 2.5 percent of it's maximum current, the rectifier will briefly raise it's output voltage by 0.5 V (for a 48 V system) once per minute. If the rectifier cannot source at least 2.5 percent of it's maximum current, the ramp test will fail and a Rectifier Fail alarm will activate.

5.3.6. Configure the shunts

By default the system has one shunt. You may add or remove shunts as needed.

To configure a shunt you need an ADIO module with current inputs. The shunt will map the current inputs from the ADIO module to the **Load Current Source** field of the Load Configuration table or the **Battery Current Source** field of the **Battery Configuration** table.

To configure a shunt:

1. Go to **Systems > DC System > Inventory > Shunts**. You will see a list of shunts in the system. Add or remove shunts from this page.
2. Select the **GO TO** button for the shunt you want to configure.
3. In the **Configuration** table, assign the shunt a name and description. We recommend that you assign the shunt a name that represents the actual shunt. For example you might name it **Battery Shunt**.
4. Select the **Shunt Current Source**. This is the current input on an ADIO module that takes a voltage reading across the shunt.
5. Enter the **Range in Amps** for the shunt.
6. Enter the **Range in Millivolts** for the shunt.
7. Enter the **Offset Calibration** for the shunt if the shunt reading error is too high.

5.3.7. Configure the system loads

By default the system has one load. You may add or remove loads as needed.

To configure each load:

1. Go to **Systems > DC System > Inventory > Loads**. You will see a list of loads in the system. Add or remove loads from this screen.
2. Select the **GO TO** button for the load you want to configure.
3. In the **Configuration** table, assign the load a name and a description. We recommend that you assign the load a name that represents the actual load.
4. Select the **Load Voltage Source**. This is the voltage input on an ADIO module that takes a voltage reading near the load.



Notice: *If you do not have this connected, you can select the input that reads the battery voltage or system voltage.*

5. Select the **Load Current Source**. This is the shunt input that reads the load current. If you have a real shunt reading for the load current, then select the shunt from the dropdown menu. If you don't see the shunt you want, then create it.

If you do not have a shunt for reading the load current, then select the 'virtual' input that calculates the load current by subtracting the total rectifier output current minus the battery current.

6. Select the **EDIT** button for the **Load Breaker/Fuse Source**. Select the digital input on the ADIO module which is connected to monitor the breaker or the fuse.

If you need to change the polarity for the **Load Breaker/Fuse Open** alarm, go to the **Modules** menu and select the appropriate ADIO in the **CAN Modues** table. Then, open the details of the appropriate digital input from the **Digital Inputs** table and change the **Active When** entry accordingly.

7. Configure the load alarms.

5.3.8. Configure the current transducer

The system, by default does not contain any current transducers. You can add or remove current transducers as needed. To configure a current transducer you need a voltage input on an ADIO module. To configure a current transducer with an Cordex® CXC HP CT-IPM module, you need a shunt input on an ADIO module.

To configure a current transducer:

1. Go to the system where you want to add the transducer and navigate to the inventory page. Go to **Systems > DC System > Inventory > Other Transducers**. In the **Other Transducers** table, there will be a list of current transducers in the system. Add or remove them from this page.

You may be using a current transducer with **Interface & Power Module (IPM)**. This device takes the voltage reading from a current transducer and divides the reading by 50. The factored voltage reading is then sent to the Cordex® CXC HP L-ADIO peripheral shunt input.

2. Select the **GO TO** button for the **Current Transducer** you wish to configure.
3. In the **Configuration** table, select **Configure Current Transducer** to launch the wizard and complete each step to configure the transducer.
4. Enter the **Measurement Range** in amps.
5. Enter the **Range in Volts**.
6. Select **CT Current Source**. This can be any voltage source.
7. Optional: enter the **Offset** calibration for the **Current Transducer** if the reading error is too low or high.

5.3.9. Configure the general purpose transducer

The system, by default does not contain any general purpose transducers. You can add or remove general purpose transducers as needed. To configure a general purpose transducer you need a voltage input on an ADIO module.

To configure a general purpose transducer:

1. Go to the system where you want to add the transducer and navigate to the inventory page. Go to **Systems > DC System > Inventory > Other Transducers**. In the **General Purpose Transducers** table, there will be a list of general purpose transducers in the system. Add or remove them from this page.
2. Select the **GO TO** button for the **General Purpose Transducer** you want to configure.
3. In the **Configuration** table assign a name and a description.
4. Select **Transducer Input Source**. This can be any voltage source or a custom data.
5. Enter the **Transducer Input Minimum in Volts** and **Transducer Input Maximum in Volts**.
6. Enter the **Transducer Output Minimum** and **Transducer Output Maximum**.
7. Select **Units and Precision**.
8. **Optional:** Enter the **Offset** calibration for the calculated **Value** if the reading error is too low or high.

The **Calculated Slope** and the **Offset** are used to convert the **Input Source Value** to the **Value**. The value is displayed in the selected units and precision.

5.3.10. Configure the system disconnects

By default the system has one disconnect. You can add or remove disconnects as needed.

There are two types of non-latching disconnect, a legacy disconnect, and a general purpose disconnect, but each are configured as follows:

1. Go to **Systems > DC System > Inventory > Disconnects** and select the **Create Disconnect** button to launch the **Create Disconnect** wizard.
2. Both types of disconnects have a name, voltage disconnect, and connect thresholds and a relay to map. The wizard for the general purpose disconnect has three extra configurations that can be used to customize the behavior of the disconnect: **Allow Disconnect During Battery Test**, **Require AC Input For Reconnect**, **Required Time to Stay Disconnected**. These extra configurations are most useful when setting up a load shedding disconnect.
3. When the wizard is complete the disconnect is functional but won't have any customizations required for alarming, or load shedding. If further configuration is required, select the **GO TO** button to continue configuration.
4. In the **Digital Inputs for Alarms** configuration table, assign the digital inputs that are used to monitor the state of the physical contactor.
5. In the **Alarms** table, configure the alarms.
6. For the legacy disconnect, it is possible to configure the following additional disconnect options:
 - **Disconnect on Time After AC Fail**: This will open the disconnect after a certain amount of time when AC has failed. This feature is used when configuring a disconnect for load shedding.
 - **Disconnect on Battery State of Charge** table. This feature is used when configuring a disconnect for load shedding.
7. For a general purpose disconnect, it is possible to configure up to three user defined disconnect and reconnect conditions. An optional disconnect condition is configured the way as an optional reconnect condition:
 - **Enable**: If desired, set this to **Enabled**
 - **Value to Test**: Set this to a value that the condition should operate on. It is possible to use a **Custom Data** here for added flexibility.

- **Logic:** Select a logical operation: greater than, less than, is True and is False
- **Limit:** When using greater than or less than, set a number to compare **Value to Test** against.

Ensure that any optional disconnect conditions cannot be true at the same time as any optional reconnect conditions, otherwise the disconnect may get stuck in either the disconnected or reconnected state.

5.3.10.1. Configure a battery disconnect with latching contactor

To configure a battery disconnect with latching contactor:

1. Go to **Systems > DC System > Inventory > Disconnects** .
2. In the **Disconnects** table, select the **Create Disconnect** button to launch the wizard.
3. At the **Select Disconnect Type** step, select **Battery Disconnect with Latching Contactor** and select the **Next** button to exit the wizard.
4. A newly created **Disconnect** will be displayed in the **Disconnects** table.
5. Select the **GO TO** button next to the newly created disconnect. In the **Configuration** table, for the disconnect, configure the following:
 - a. **Enable:** This will enable the disconnect.
 - b. **Relay to Close:** This is the relay that will be used to close the latching contactor. Using the selector, set this relay to the ADIO module relay which corresponds to the relay input of the latching contactor interface which will close the latching contactor.
 - c. **Relay to Open:** This is the relay that will be used to open the latching contactor. Using the selector, set the relay to the ADIO module relay which corresponds to the relay input of the latching contactor interface which will open the latching contactor.
 - d. **Contactor State Source:** This is the digital input that is wired to sense the contactor state. Using the selector, set the source to the digital input which corresponds to the auxiliary input of the latching contactor interface. For proper operation of a battery disconnect with latching contactor, this source is required to be configured.
6. In the **Disconnect On Voltage** table, configure the following:
 - a. **Voltage Disconnect Threshold:** This is the voltage at which the disconnect will activate and open the connection. This threshold cannot be disabled.
 - b. **Voltage Connect Threshold:** This is the voltage at which the disconnect will de-activate and reconnect. This threshold cannot be disabled.

5.3.11. Configure lead acid or NiCad battery parameters

The system is only permitted to have a single battery. The battery may consist of multiple battery strings. When the DC System is being created using the DC system creation wizard, the user will be given the option of adding a battery to the system, or not.

If a battery is required, configure battery parameters:

1. Go to **Systems > DC System > Inventory > Battery**. On the **Battery** page, you will see several tables, with **Status**, **Configuration**, **Alarms**, **Battery Strings**, and **Charging/Discharging Threshold**. There is also a table with a list of battery strings, and a button to add more.
2. In the **Configuration** table, assign the battery a name and description if required.
3. Edit the **Battery Voltage Source** and **Battery Current Source** if necessary. Note that it is possible to map the entire battery to an ADIO module input for the voltage and current sources, but is recommended to leave those values at their defaults at this level. The defaults will average the voltages of the battery strings, and sum the currents.
4. In the **Battery Strings** table, select the **Add Battery String** button to launch the wizard which will add more battery strings if necessary.

5.3.11.1. Configure the battery strings

A battery string can be configured by editing the necessary values manually, or by launching the **Add Battery String** wizard (to create and configure a number of new battery strings), or the **Configure Battery String** wizard to set the configuration of an existing battery string.

Configure the battery string configuration values manually:

1. Select the **GO TO** button to step into the details for each string. Do the following steps on each of the battery strings in your system.
2. In the **Configuration** table, set a **Name** and **Description** for each string, if desired.
3. In the **Configuration** table, select the **Battery Voltage Source**. This is the voltage input on an ADIO module that takes a voltage reading as near the battery as possible.
4. In the **Configuration** table, select the **Battery Current Source**. This is the shunt input that reads the battery current. If you have a real shunt reading the battery current, then select the shunt from the drop-down menu. If you don't see a shunt, you should create one now.

If you do not have a shunt for reading the battery current, then select the 'virtual' input that calculates the battery current by subtracting the total rectifier output current minus the load current

5. Temperature sensors can be added via the **Temperatures** table. See the next section for information on how to do this.
6. In the **Configuration** table, configure the **Capacity Rating**. This value may be available from the battery specification sheet. Use the capacity at the 20-hour rate (C/20).
7. In the **Configuration** table, configure the **Open Circuit Voltage**. This value is may be available from the battery specification sheet. If not, leave at the default value.
8. In the **Configuration** table, launch the **Configure Peukert Exponent** wizard to configure the **Peukert Exponent**. This value may be available from the battery specification sheet.

If the Peukert exponent (n) is not supplied in the battery specification, calculate it by the equation:

$$n = \frac{[\log(T_2) - \log(T_1)]}{[\log(I_1) - \log(I_2)]}$$

where T is the discharge time in hours and I is the corresponding discharge current in amps. Both T and I are often available in the battery specification sheet.

9. Under the **Breaker/Fuse Source**, select the digital input on the ADIO module that is connected to monitor the breaker or fuse.
10. Optional: Configure the **Midpoint Voltage Source** if your ADIO module is wired to read the battery midpoint voltage.
11. In the **Alarms** table, configure the related alarms.

5.3.11.2. Configure battery strings wizard

A battery string can be configured by editing the necessary values manually, or by launching the **Add Battery String** wizard.

To add a new battery string:

1. In the **Battery Strings** table, select the **Add Battery String** button to launch the wizard.
2. Under **Battery Parameter Source**, choose the source of battery parameters. You can choose to set the parameters based on the battery model or copy them from an existing battery string. The following steps will assume that you have chosen to set the parameters based on the battery model, as this is the most complex case. Choose **Use Parameters based on Battery Model** and select **Next**.
3. On the **Select Battery Model** page, choose the battery manufacturer and battery model. If yours is not on the list, choose the most similar battery. Once completed, select **Next**.
4. On the **Verify Battery Parameters** page, review the battery parameters. The values will be pre-populated. The numbers may be edited at this step to make sure that they match your battery string. Select **Next**.
5. On the **Number of New Strings** page, select the number of strings you wish to add, then select **Next**.
6. If you have chosen to add more than one string, you will get be taken to the **Clarify Mappings** page. Clarify the voltage source and shunt information, then select **Next**.
7. On the **Name the String(s)** page, enter a name for each of the new strings, if desired. Select **Next**.
8. On the **Map the String(s)** page you will be able to map a voltage source (either one per string, or an overall voltage reading). You can also map a midpoint voltage for each string and a breaker or fuse source for each string. If you chose to add a current source for each string, that field will also be available to edit here.
9. The **Results** page will show whether the addition of the battery strings was successful. Select **Done** to exit the wizard

5.3.11.3. Update system parameters based on battery parameters

When a system is created, default values are used for battery parameters such as Float Voltage, Equalize Voltage, Temperature Compensation Slope, and Charge Current Control maximum current. Battery strings usually have their own recommended values for these parameters, available in the battery data sheets. For battery models often used with the controller, these values are pre-populated into the battery

string settings when a user chooses to create a battery string based on a known model. However, the system values are not automatically updated, in order to avoid unexpected results for users who have already set their system settings the way they desire. If the user adds or removes battery strings, or updates the battery parameters within the strings, and then wishes to update the System parameter accordingly, they can do this using the **Update System Parameters** wizard.

To update the system parameters based on recommended values of the battery strings:

1. In the **Battery Strings** table, select the **Update System Parameters** button.
2. A wizard window will open. It will contain a comparison of the current system parameters that are in effect, with the new ones. Note that the new values are calculated based on the recommended values from all battery strings in the system, not just any new or changed battery strings. The values are calculated as follows:
 - **Float Voltage:** The average of all valid recommended float voltages of the battery strings in the system.
 - **Equalize Voltage:** The average of all valid recommended equalize voltages of battery strings in the system.
 - **Temperature Compensation Slope:** Numerical lowest of all the recommended slopes of battery strings in the system. Since the slope is negative, this means the highest slope will be chosen, which is the safest option if strings with different recommended temp comp slopes are being used.
 - **Charge Current Max:** The lowest of all the recommended current values of battery strings in the system, but multiplied by the number of strings in the system. For example, if there are two battery strings and one has a recommended Charge Current Max. of 8 A and the other has a recommended Charge Current Max. of 3 A, the new value will be $3 \text{ A} \times 2 = 6 \text{ A}$.
3. To accept these values as the system parameters, select **Next**. To cancel and leave the values as they are, select **Cancel**.
4. The **Results** page will show whether the System Parameters were updated successfully.

5.3.12. Configure Polarium battery parameters

The DC system is only permitted to have a single battery, though the battery may consist of multiple Polarium battery modules. Battery modules are automatically added to the battery system according to the protocol bridges assigned to the system. Each protocol bridge can communicate with up to 26 Polarium battery modules.



Notice: *The **Maximum Temperature** and **Minimum Temperature** of all the battery modules are logged as performance logs. To see these logs, first follow the steps below to add battery modules to your system. Then go to **Logs > Performance** to view the appropriate temperature log for the polarium battery.*

To add Polarium battery modules to the DC system for the first time:

1. Connect a Polarium Protocol Bridge on the CAN bus, and ensure the Polarium battery modules are connected to the protocol bridge.
2. When adding polarium modules for the first time, remove the default battery system in order to add one that is compatible with polarium batteries. To do this, go to **Systems > DC System > Inventory > Battery**. If a battery already exists, remove it.
3. Launch the **Add Battery** wizard, and select **Add Polarium Battery** from the dropdown list. Finish the wizard.
4. The Polarium Battery Modules connected via the protocol bridges will begin to appear in the **Polarium Battery Modules** table. If the modules do not appear, the protocol bridges may not be assigned to the battery. If this is the case, use the **Configure Polarium Battery** wizard to manually assign the appropriate protocol bridges to the battery.
5. By selecting the details button for a given battery module, the details page for that battery module will be displayed. Here, the Name and Description can be set if desired; this can be helpful to record the battery module replacement date, for example.

5.3.13. Configure the battery temperature sensors

The battery can have any number of battery temperature sensors. These should be added at the battery string level.

In previous releases, it was possible to add temperature values at the overall battery level. If you upgrade from a release that allowed that and you had temperature sensors at the overall battery level, those will be maintained and can still be used, but no new temperature sensors can be added at that level. You should add new temperature sensors on the individual battery strings.

Adding temperature sensors can be done using the **Add Multiple Temperature Values to Strings** wizard from the overall battery page. Otherwise, they can also be added manually from the individual battery string pages. Depending on your requirements, you can choose to have only a single temperature reading for your battery, or one for each battery string, block, or cell.

5.3.13.1. Add multiple temperature values to strings

To add multiple temperature values use the Add Multiple Temperature Values to Strings wizard:

1. In the first step of the wizard, you can choose whether to add temperature sensors to a single string, or to all of your battery strings. The following description will assume you chose to add to all your strings, but the steps to add to a single string are very similar. Choose **Add the same number of temperature sensors to all your battery strings**. from the dropdown menu on the first page of the wizard. Select **Next**
2. Choose how many sensors you would like to add to each string. The same number will be added to each of your existing battery strings. Select **Next**

3. In the third step of the wizard, you will be able to map each of these new temperature sensors to a temperature reading from an ADIO module, Custom Data, or other calculated temperature value. Select **Next**
4. The temperature readings will be added to your battery strings, and a success or failure message displayed.

5.3.13.2. Add battery temperature values manually

To add and configure battery temperature sensors manually from the battery string pages:

1. Go to **Systems > DC System > Inventory > Battery**. Select on the details of an individual battery string.
2. On the **Temperatures** table, select **Add Temperature Value**. The table will be populated with a new line for temperature value.
3. Select the **GO TO** button on the right-side of the line for the new temperature value.
4. A new page displays with information about the new temperature value. In the **Configuration** table you can enter an optional name and description if desired.
5. It is mandatory to select a **Battery Temperature Source** for the temperature value. Select the **GO TO** button and select the desired temperature input. The dropdown list displays all temperature inputs present on all ADIO modules.
6. In the **Status** table, verify that the temperature is now reading a temperature value.
7. Repeat these steps for each temperature value required. When finished navigate back to the **Battery** page.

Enable the temperature sensor alarms as needed.

8. Go to **Modules**. Select each ADIO module you are using, and then view the **Alarms** table. For the temperature sensor you are using, verify that the **Temperature Sensor Failure Alarm** is enabled.

In the **Temperatures** table, you should now see a list of temperature values. The battery **Status** table should show the minimum, average and maximum temperature values as determined from the list of temperatures. The battery **Status** table at the overall battery level will also contain the minimum, maximum, average, and active temperatures across all temperatures sensors within the battery, including all temperatures for both the strings and the battery itself. At the DC System level, battery temperature should now show a valid reading on the **Systems > DC System > Status** page.

5.3.14. Configure the charging system function

There is no way to turn off battery charging via the controller, but you can control the bulk and absorption stages.

You can enable and disable charge current control (CCC) in the bulk charging stage. For example, in a situation where multiple power systems are connected to the DC bus and a decrease in current on one system would result in an increase in current on the second system you may want to disable CCC. CCC

may be suspended for various reasons. If this is the case the **Charge Current Control State** will say **Suspended** and the suspend reason will be shown in **Charge Current Control Suspended Reason**.

You can enable/disable an increased voltage in the absorption charging state. If you disable **Elevated Absorption Charging** or the arming threshold was not reached, then the absorption charging stage will be done at the float voltage. You can configure **Elevated Absorption Charging** to terminate on a timeout and a low current threshold.

Absorption charging, at an increased voltage, is normally done for deep discharges only so there is an **Absorption Arming Threshold**. A battery discharge must reach a voltage below the **Absorption Arming Threshold** for **Elevated Absorption Charging** to be activated on the recharge.

To configure the charging system:

1. Go to **Systems > DC System > System Functions > Charging**. Note that you must have a battery defined in the DC System in order to have this menu item available under **System Functions**.
2. In the **Primary Charge Current Control** table, ensure the **Charge Current Control** setting is **Enabled** (this is the default).
3. Set the **Charge Current (C/X)** limit to an appropriate value (for example, 10-hrs). See your battery manufacturers' data sheet for charging recommendations.



Notice: *The charge current limit in amps cannot be set to an arbitrarily low value. The charge current control feature uses the rectifier's ability to limit its output current. All rectifiers have a lower limit to which their current can be adjusted and this value is documented in the rectifier hardware manual. For example, if you have two Cordex® HP 48-1.2kW rectifiers, they have a minimum current limit of 23 percent of maximum current. This means the lowest amount of current they can output is $2 \times 25A \times 0.23 = 11.5 A$. If the load is 5 A, the lowest charge current limit to the battery will be $11.5A - 5A = 6.5 A$. A charge current limit of less than 6.5 A cannot be achieved with this arrangement.*

4. From the **Absorption Charging Configuration** table, enable **Elevated Absorption Charging**.
5. Set the **Elevated Absorption Arming Threshold** to a voltage that indicates a deep enough discharge to warrant absorption charging at a higher voltage.
6. Set the **Elevated Absorption Voltage** to a value recommended by the battery manufacturer.
7. Set the **Elevated Absorption Termination Threshold** in amps.
8. Set the **Elevated Absorption Timeout** in hours.
9. Set the **Terminate/Disallow Elevated Absorption When True** setting to either prevent or terminate elevated absorption based on a custom data condition (if desired).

5.3.15. Configure the temperature compensation system function

Temperature compensation uses the battery temperature to adjust battery voltage. The default value for temperature compensation is $-2.5 \text{ mV}/^{\circ}\text{C}/\text{Cell}$ ($-1.5 \text{ mV}/^{\circ}\text{F}/\text{Cell}$).

To configure temperature compensation:

1. Go to **Systems > DC System > System Functions > Temperature Compensation**. Note that you must have a battery defined in the DC System in order to have this menu item available under **System Functions**.
2. Enable/disable **Temp Comp in Float**, **Temp Comp in Equalize** and **Temp Comp in Absorption**
3. Set the **Slope** based on the battery manufacturer's information.
4. Set the **Upper Temperature Breakpoint Voltage** to a value below the float voltage.
5. Set the **Lower Temperature Breakpoint Voltage** to a value above the float voltage.
6. Adjust the values and enable or disable the **Temp Comp Sensor Fail** and **Temp Comp Voltage Warning** alarms.

5.3.16. Configure battery runtime and health estimation

The Battery Runtime and Health Estimation is used to calculate **Estimated State of Charge** during charges and discharges, **Estimated Battery Health** for discharges that exceed a 20 percent depth of discharge (DOD) and **Estimated Battery Runtime** at all times.

To configure battery runtime and health estimation:

1. Go to **Systems > DC System > System Functions > Battery Runtime & Health Estimation**. Note that you must have a battery defined in the DC System in order to have this menu item available under **System Functions**.
2. In the **Configuration** table, select the **EDIT** button to enable or disable **Battery Estimation**.
3. Set the **Load Model**. The load model has no affect on calculating **Estimated State of Charge** or **Estimated Battery Health** but it has a significant impact on calculating the **Estimated Battery Runtime**.
 - a. With the constant current model, the load current is expected to stay the same as the load voltage decreases.
 - b. With the resistive model, the load current is expected to decrease as the load voltage decreases.
 - c. With the constant power model, the load current is expected to increase as the load voltage decreases.
4. Set the **Battery LVD**. If there is no BLVD, this can be left unknown.

5.3.17. Run a manual battery test

Once your DC System is set up, running a manual battery test may be as simple as pressing the **Start Manual Battery Test** command.

1. Go to **Systems > DC System > System Functions > Battery Test**. Note that you must have a battery defined in the DC System in order to have this menu item available under **System Functions**.
2. From the **Configuration** table, set the **Termination Voltage**, **Timeout** and **Termination SOC** values.

Which ever one of these conditions occurs first will terminate the battery test.

3. From the **Status** table, select the **Start Manual Battery Test** command.

To start a battery test, the **Battery Mode** must be in the **Float** mode. Otherwise the battery test cannot start.

There are a number of reasons why the test might terminate early. Two examples are a weak battery detected where the voltage drops too quickly and AC Failure being reported by the rectifiers.

If **Battery Runtime and Health Estimation** is **Enabled** you should see the battery state of charge (SOC) and runtime remaining RTR, update during the test. If the test runs long enough, the test results should be stored in the **Battery Log** page.

5.3.18. Configure power save

Power Save works to improve the efficiency of the system by optimizing the output power of the rectifiers. This section describes how to configure **Power Save**.

Power Save should only be used on systems with a battery. If the system supports 120 to 240 Vac input voltage operation and is operating at less the 208 Vac - do not use **Power Save**.

1. Go to **Systems > DC System > System Functions > Power Save**.
2. In the **Configuration** table, enable **Power Save**.
3. Set the percentage of **Module Power for Maximum Efficiency**. The default value is 80%.

For best efficiency performance, refer to the specifications in the module's hardware manual. Ensure this value is below the user configured current or power capacity in the **Rectifiers > Configuration** menu.

4. Set the module rotation period in days. The default is seven days.

Module rotation occurs at 3:00 AM.

5.4. Connect to other systems

The output of a DC system can be used to power DC loads as well as converter and inverter systems. These power systems act as a load on the DC system and you have to represent them as loads on the DC system to ensure the DC system calculations are accurate.

5.4.1. Represent a converter system as a DC load

A converter system is represented on a DC System like an ordinary DC load.

To configure a converter system as a DC load:

1. Go to **Systems > DC System > Inventory > Loads**. You will see a list of loads in the system. Add or remove loads from this screen.
2. Select the **GO TO** button for the load you want to configure.
3. In the **Configuration** table, assign the load a name and a description. We recommend that you assign the load a name that represents the actual load.
4. Select **Load Voltage Source**. This voltage is the DC input to the Converter System. This is normally a voltage input on an ADIO that measures the DC system voltage.

If you do not have this connected, you can select the input that reads the battery voltage or system voltage.

5. Select Load Current Source. This is normally the **Converter System > Total Input Current** value.
6. Configure the related load alarms.

5.4.2. Represent an inverter system as a DC load

An inverter system will normally have an AC input and a DC input. The inverter system may only be using the DC input when the AC input has failed. When the AC input is available, the inverter may take all of its power from the AC input.

On the controller, inverter systems can measure the DC current they are using and they can also calculate how much DC current they are expecting to use, should their AC input fail. The DC System uses both of these values to calculate the battery runtime remaining in all situations.

To configure an inverter system as a DC load:

1. Go to **Systems > DC System > Inventory > Loads**. You will see a list of loads in the system.
2. Select the **Add Inverter System Load** button the **Loads** table to add a new load to the list.
3. Select the **GO TO** button for the load you want to configure.
4. In the **Configuration** table, assign the load a name and a description. We recommend that you assign the load a name that represents the actual load.
5. Select the Load Voltage Source. This voltage is the DC input to the Inverter System. This is normally a voltage input on an ADIO that measures the DC System voltage.

If you do not have this connected, you can select the input that reads the battery voltage or system voltage.

6. Select the **Load Current Source**. This is normally the **Inverter System > DC Input Current** value which is measuring how much DC current the inverter system is using right now.

7. Select the **DC Input Current In AC Failure Source**. This is normally the **Inverter System > Expected DC Input Current In AC Failure Source** value which is measuring how much DC current the inverter system is expecting to use should the AC input fail.
8. Configure the related load alarms.

6. Converter systems

This section provides an overview of converters, how they function, and how to configure a converter system.

6.1. Introduction to converter systems

A DC-DC converter system takes a DC input voltage and converts it to a different output voltage. A converter system provides flexibility that allows you to maintain a single voltage battery system. Converters provide DC-DC power conversion (for example, from +24 V to -48 V) to produce a consistent voltage source for equipment that is not compatible with the primary plant voltage. Converters can be used to create dual voltage capability in new systems or upgrades to existing DC plants. They provide tight voltage regulation for sensitive loads as well as galvanic isolation.

Mixed converter system

Different types of converters must be used within different converter systems, check your system and rectifier or converter manuals for a list of any default parameters or requirements.

Components of a converter system

A converter system consists of a source, converters and a load as shown in the following diagram. Converters should have dedicated fuse or circuit breaker positions on the main DC power system for protection and isolation.

Figure 6-1 Example converter system

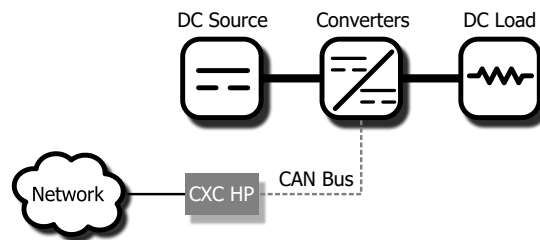

Quick reference for configuring a converter system

Figure 6-2 Quick reference for configuring a converter system

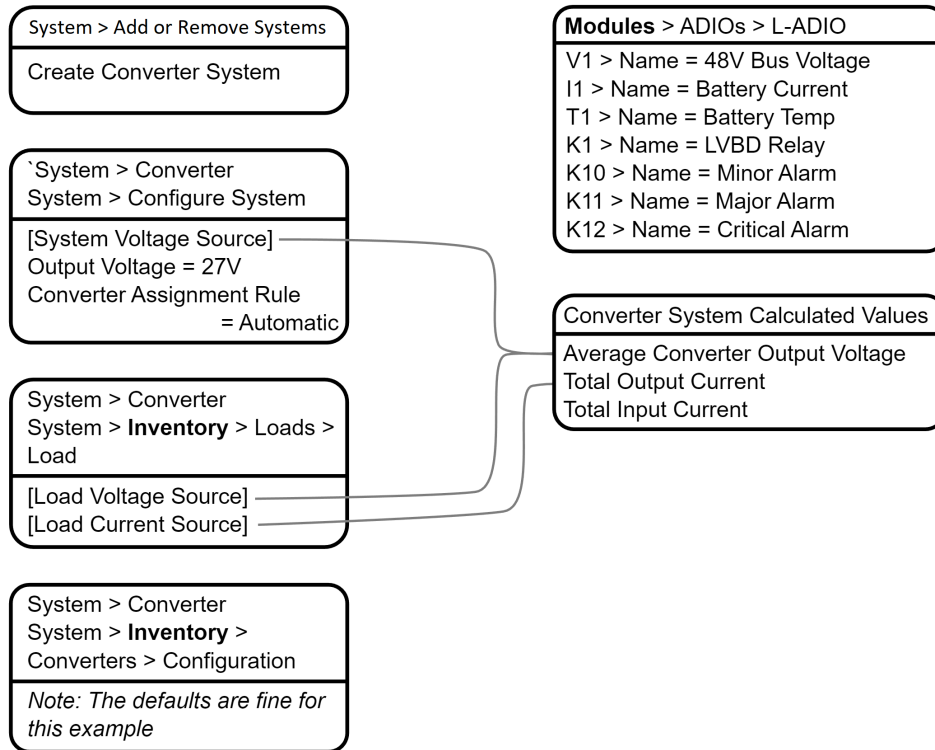

6.2. Creating a converter system

There is no converter system on a new controller. Creating a converter system is done using the **Create System** wizard. In the current release, only a single converter system is supported, so if a system already exists on the controller, the option to create a new converter system will not be available.

You can also import a configuration file containing a converter system from another controller.

A new power system can be created from the controller LCD or the web interface, via the **Systems > Add or Remove Systems** menu. Both have wizard assistance to help step you through the process to create the new system. You can create either a 48V-24V system or a 24V-48V system. When the system is created, an associated load is also created.

The converter system created will have a reasonable set of defaults and associated alarms. Optional converter items, such as **Name**, **Description**, **System Number**, and **Serial Number** can be used to describe and organize your system.

The **Converter Assignment Rule** setting controls how newly discovered converters are treated. The two options are **Manual** and **Automatic**. Using **Manual**, groups all new converters into **Unassigned Modules**, and then you can add them to the system manually. Selecting **Automatic** adds new converters to the system automatically. This is the default setting.

You can configure the converter alarms associated with the system. You can enable or disable the alarms, change the priority, map relays to the alarms, and where applicable, modify the thresholds.

To create a converter system:

1. Go to **Systems > Add or Remove Systems**.
2. Select **Create Converter System**. Name the system if required.
3. In the **Select System Type** dropdown menu.
4. Step through the rest of the wizard instructions.
5. Use the **Configure Converter System** wizard to configure the basic system settings and the system inventory.

6.2.1. Creating a system from a configuration file

A system can be created by importing from a configuration file. See the *Importing a system* section for more information.

6.3. Configure the converters

These settings include start delay, output voltage, or over-voltage protection threshold.



Notice: *The output voltage is also the voltage that the converters default to if they lose communication with the controller. The converters will drop any of the adjustments made by the controller to perform load sharing and just try to meet the configured output voltage.*

This feature has a time delay that varies according to converters. Most converters revert to output mode after five minutes. Check the converter manual for a list of default parameters.

To configure the converters:

1. Go to **Systems > Converter System > Inventory > Converters > Configuration**.
2. In the **Configuration** table, set up your converter group configuration settings. These include, **System Start Delay** and **Over-voltage Protection** threshold.
3. Configure the settings for the converters. The values for these settings depend on your specific system.

6.4. Configure the shunts

By default the system has no shunts. You may add or remove shunts as needed.

To configure a shunt you need an ADIO module with current inputs. The shunt will map the current inputs from the ADIO module to the **Load Current Source** field of the **Load** configuration table or the **Battery Current Source** field of the **Battery Configuration** table.

To configure the shunts:

1. Go to **Systems > Converter System > Inventory > Shunts**. You will see a list of shunts in the system. Add or remove shunts from this page.
2. Select the **GO TO** button for the shunt you want to configure.
3. In the **Configuration** table, assign the shunt a name and description. We recommend that you assign the shunt a name that represents the actual shunt. For example you might name it **Battery Shunt**.
4. Select the **Shunt Current Source**.

This is the current input on an ADIO module that takes a voltage reading across the shunt.

5. Enter the **Range in Amps** for the shunt.
6. Enter the **Range in Millivolts** for the shunt.
7. Enter the **Offset Calibration** for the shunt if the shunt reading error is too high.

6.5. Configure the loads

By default the system has one load. You may add or remove loads as needed.

To configure the loads:

1. Go to **Systems > Converter System > Inventory > Loads**. You will see a list of loads in the system. Add or remove loads from this screen.
2. Select the **GO TO** button for the load you want to configure.
3. In the **Configuration** table, assign the load a name and a description. We recommend that you assign the load a name that represents the actual load.
4. Select the **Load Voltage Source**. This is the voltage input on an ADIO module that takes a voltage reading near the load.

If you do not have a sensor connected, you may want to select the **Average Converter Output Voltage**.

5. Select the **Load Current Source**. This is the shunt input that reads the load current. If you have a real shunt reading for the load current, then select the shunt from the dropdown menu. If you don't see the shunt you want, then create it.

If you do not have a shunt for reading the load current, you may want to select the **Total Output Current** for the converter system.

6. Select the **EDIT** button for the **Load Breaker/Fuse Source**. Select the digital input on the ADIO module which is connected to monitor the breaker or the fuse.

If you need to change the polarity for the **Load Breaker/Fuse Open** alarm, go to the **Modules** menu, from the All Modules table, select the ADIO module required, and then select the **GO TO** button to access the **Digital Inputs** table.

7. Configure the related load alarms.

6.6. Configure the current transducer

The system, by default does not contain any current transducers. You can add or remove current transducers as needed. To configure a current transducer you need a voltage input on an ADIO module. To configure a current transducer with an Cordex® CXC HP CT-IPM module, you need a shunt input on an ADIO module.

To configure a current transducer:

1. Go to the system where you want to add the transducer and navigate to the inventory page. Go to **Systems > DC System > Inventory > Other Transducers**. In the **Other Transducers** table, there will be a list of current transducers in the system. Add or remove them from this page.

You may be using a current transducer with **Interface & Power Module (IPM)**. This device takes the voltage reading from a current transducer and divides the reading by 50. The factored voltage reading is then sent to the Cordex® CXC HP L-ADIO peripheral shunt input.

2. Select the **GO TO** button for the **Current Transducer** you wish to configure.
3. In the **Configuration** table, select **Configure Current Transducer** to launch the wizard and complete each step to configure the transducer.
4. Enter the **Measurement Range** in amps.
5. Enter the **Range in Volts**.
6. Select **CT Current Source**. This can be any voltage source.
7. Optional: enter the **Offset** calibration for the **Current Transducer** if the reading error is too low or high.

6.7. Configure the general purpose transducer

The system, by default does not contain any general purpose transducers. You can add or remove general purpose transducers as needed. To configure a general purpose transducer you need a voltage input on an ADIO module.

To configure a general purpose transducer:

1. Go to the system where you want to add the transducer and navigate to the inventory page. Go to **Systems > DC System > Inventory > Other Transducers**. In the **General Purpose Transducers** table, there will be a list of general purpose transducers in the system. Add or remove them from this page.
2. Select the **GO TO** button for the **General Purpose Transducer** you want to configure.
3. In the **Configuration** table assign a name and a description.
4. Select **Transducer Input Source**. This can be any voltage source or a custom data.
5. Enter the **Transducer Input Minimum in Volts** and **Transducer Input Maximum in Volts**.
6. Enter the **Transducer Output Minimum** and **Transducer Output Maximum**.

7. Select **Units and Precision**.

8. **Optional:** Enter the **Offset** calibration for the calculated **Value** if the reading error is too low or high.

The **Calculated Slope** and the **Offset** are used to convert the **Input Source Value** to the **Value**. The value is displayed in the selected units and precision.

7. Inverter systems

This section provides an overview of inverters, how they function and how to configure an inverter system.

7.1. Introduction to inverter systems

An inverter system takes both AC and 48 Vdc input and converts it to 120 Vac output voltage. The inverter system can operate in one of several modes:

- **Line (AC-AC):** When AC input is present the inverters normally take this voltage and convert it to AC at the output.
- **Inverter (DC-AC):** When AC input is lost, the inverters take the DC input voltage and convert it to AC at the output.
- **Bypass Mode:** When the maintenance bypass switch has been used to bypass the inverters and directly connect the AC input to the output.

To monitor and interact with the inverter system, the controller communicates with a sub-controllers called a T2S.

7.1.1. Components of a T2S inverter system

An inverter system typically consists of an AC source, a DC source, inverters, an AC load, input breakers, output breakers, and a bypass switch. A very large inverter system may not have a bypass switch and will use breakers to perform the maintenance bypass function.

Figure 7-1 Single T2S inverter system components

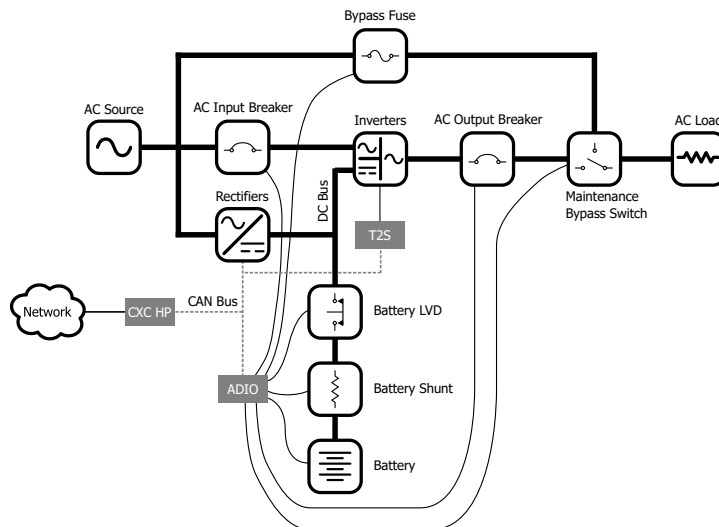

7.1.2. Quick reference for configuring an inverter system

Figure 7-2 Quick reference for configuring an inverter system

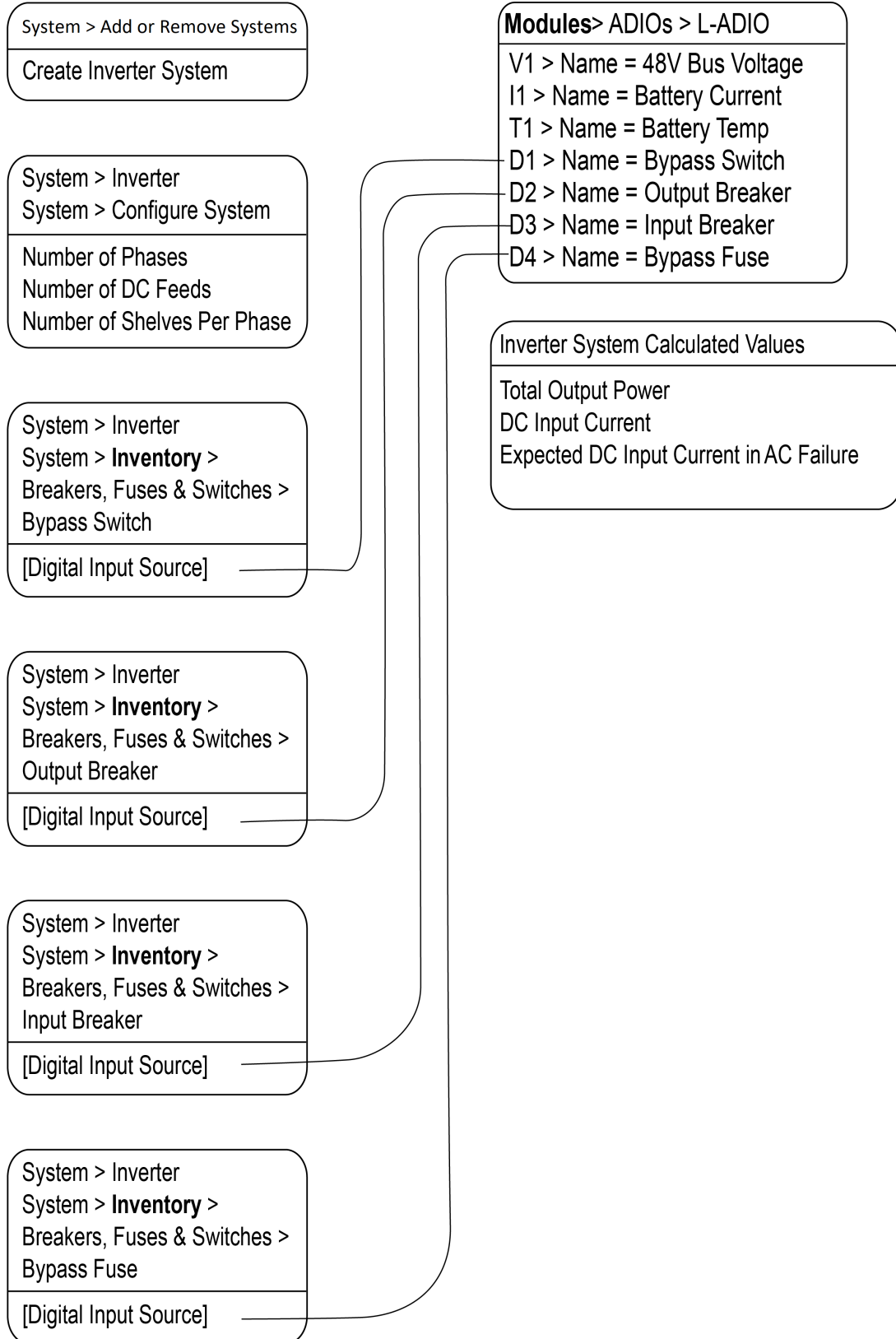

7.1.3. Phase and group data

The inverter system will aggregate and display data about the output phases, AC input groups, and DC input groups.

The output phase information includes data such as the output voltage, output power (in VA and W), frequency, and loading.

The AC input group information include data such as the input voltage, input power (VA and W), and frequency for each phase (there is a one-to-one correspondence between the phase and AC input group).

The number of DC input groups is the number of redundant DC input sources. An example is a system with separate batteries. The DC input group information includes data such as the DC voltage, current and power (W).

To get information on **Phase and Group Data**, go to **Systems > Inverter System > Phase and Group Data**.



Notice: *When the AC output is light (10 percent or less) or the phases are unbalanced, some of the data, (percentage of DC input, DC input current or AC output power readings) will tend to be inaccurate and inconsistent. This is normal. Once the AC output is loaded sufficiently the readings will be correct.*

7.1.4. Live alerts

The T2S systems in an inverter system report alert status relating to the T2S system or its inverters via the **Live Alerts** table. Go to **Systems > Inverter System > Live Alerts**. The table shows the **Owner** of the alert, the alert **Type** and the **Alert Name**.

The **Owner** of the alert indicates if the alert belongs to the T2S system or to a specific inverter.

The **Type** of alert indicates if the alert is an individual T2S system alert, an inverter alert or a system alert. A “system” alert is an alert that is active on all inverters. A system alert usually indicates a configuration error or a problem with an input source or an output which is affecting all inverters at the same time.

The **Alert Name** displays the name of the alert as well as a numeric code. This numeric code can be used to cross reference the alert in the T2S system log file when troubleshooting.

Additional information about a specific alert can be found in **Alerts** table of the **Owner** identified within the **Live Alerts** table.

7.1.5. System functions

The inverter system has three functions available:

- Zero Phase Shift
- AC Input Power Limit
- Manual DC Priority

These are briefly described in the following section. For information on using these functions go the **Inverter & T2S System Maintenance** section.

Zero phase shift

The output of the inverters is normally shifted from the input by five degrees for certain regulatory compliance. For some systems running on generator, it may be necessary to momentarily reduce this phase shift to zero degrees before any manual bypass operation is performed. A wizard guides you through this operation.

During the wizard, the controller will check the difference between the input voltage and output voltage (as measured line-neutral). This difference is caused by different levels of loading on input or output or unusual AC mains conditions. If the difference is greater than 6 volts, a warning indicates that proceeding with the bypass operation may result in momentary interruption of power to the load. If the difference is larger than 6 volts there is a small chance that inverters may shutdown when they detect too much current flowing into the input or output as the bypass switch is turned. If this warning is occurs, wait until input and output are closer together.

AC input power limit

This function can be used to limit the AC input power that the inverter system will take by using some of the energy from a DC bus. If there is only a battery (and no rectifiers) supplying the DC bus, this function must be manually controlled by an operator to ensure the battery is recharged once it is depleted.

Manual DC priority

This function can be used to take power from the DC bus based on a user-specified percentage. If there is only a battery (and no rectifiers) supplying the DC bus, this function must be manually controlled by an operator to ensure the battery is recharged once it is depleted.

7.2. Create an inverter system

There are two options for creating an inverter system:

- Use the **Create System** wizard via the **Systems > Add or Remove Systems** menu, and select **Create Inverter System** from the dropdown menu of systems to create.
- Use a configuration file to import an inverter system.

After an inverter system is created, it must have one T2S module assigned to it. The T2S module is a CAN device that controls and monitors the inverters.

7.2.1. Create a system from a configuration file

A system can be created by importing from a configuration file. See the *Importing a system* section for more information.

7.3. Assign a T2S module

Each inverter system requires one assigned T2S module. If the **T2S Assignment Rule** was set to **Automatic** during system creation, then a T2S module is automatically assigned once discovered on the CAN bus.

If the **T2S Assignment Rule** was set to **Manual**, go to **Systems > Inverter System > Inventory > T2Ss**, and select **Assign** in the **Modules Available for Assignment** table.



Notice: *It can take several minutes to discover a T2S module on the CAN bus, for the first time.*

7.4. Commission an inverter system

Once an inverter system has been created, and a T2S inverter controller has been assigned to the system, it can be commissioned. There are three stages to commissioning:

- Setting the system options
- Commissioning seed inverters
- Adding inverters

Setting system options

This wizard requests the following configuration information:

- Output Voltage
- Frequency
- AC Phases
- DC Input Groups
- DC Commissioning

Output voltage can be set to 120 V or 230 V. Refer to the system specifications to determine which voltage setting is correct. The output voltage normally matches the input voltage.

Frequency can be set to 60 Hz or 50 Hz is the same for both input and output. Refer to the system specifications to determine with frequency is correct. DC Commissioning can be set to No or Yes. Normally AC is input is present and this should be set to No.



Important: *It is important that these values are correct for the proper operation of system commissioning, and for adding new inverters.*

Commission seed inverters

The second stage of commissioning involves inserting one seed inverter for each phase. The seed inverter provides a reference for all other inverters in the same phase so they can learn their power

configuration and the phase angle. The commission wizard steps the user through the process. Once this is complete, there will be one inverter (per phase) in the system.

! ***Important:** Follow all wizard instructions: If a mistake is made during commissioning or the wizard encounters an error, commissioning must start over.*

Commissioning may take several minutes to complete. This process is complex due to several factors:

1. The type of AC input source connection is unknown. The AC input source may be connected as single phase, split phase, 2-pole, or three phase. The controller identifies the correct configuration of the AC input and configures the T2S inverter controller accordingly.
2. For three phase and split phase connection, the AC phase rotation is unknown. This means that if phase 1 is assumed to have a phase angle of 0 degrees, phase 2 may have a phase angle of 120 degrees or 240 degrees. The controller will identify the correct phase rotation.
3. The inverters take time to synchronize to the AC input. As the controller probes all possible combinations the inverters take at least 30 seconds after each combination before determining if they have synchronized to the AC input.

Once the correct AC input connection and the phase angle have been determined, the T2S inverter controller is configured correctly to accept more inverters.

Adding inverters

The third stage of commissioning involves inserting the rest of the inverters. This process takes time. It is recommended that you follow all the instructions within the wizard.

When an inverter is inserted, it learns its power configuration from the inverters already inserted in that phase. The controller sets the values for the following:

- AC input group
- DC input group
- The location information of bay ID, slot ID, and shelf ID
- The correct phase number and phase shift.

After all inverters are inserted into the shelves, the final step is to configure the T2S inverter controller with the parameters for the number of modules per phase, and the number of redundant modules in each phase. This information is important for the correct operation of alarms associated with redundancy, missing inverters or system overload.

! ***Important:** After configuring and commissioning is successful, make a backup of the system from the LCD via the **Shortcuts > Backup** menu. This allows the system configuration to be restored in the event of a controller replacement.*

7.5. Configure the T2S inverter controller

The configuration of the T2S inverter controller occurs primarily during the commissioning process. There are two optional settings that an operator may want set after the commissioning is complete: the T2S controller name and description.

Additionally, there are some T2S module configuration parameters for the number of modules per phase and the amount of inverter redundancy in a phase that are set during the add and remove wizards. This is why it is required to use these wizards when changing the number of inverters in a system.

To configure a T2S inverter controller:

1. Go to **Systems > Inverter System > Inventory > T2S** and select the **GO TO** button of the T2S module.
2. In the **Configuration** table, enter the **Name** and **Description**.

7.6. Configure the inverters

The inverters are normally configured automatically when using the commissioning and add inverters wizards. The inverter parameters that are configured automatically are, AC and DC input group, as well as the bay ID, shelf ID, and slot ID.

To reconfigure an inverter, remove the inverter first, using use **Remove Inverters** wizard. Add it back into the system using the **Add Inverters** wizard. This ensures that the system configuration remains correct and consistent.

Alternatively, the number of redundant inverters per phase can be changed using the **Configure Inverter Redundancy** wizard. To access the wizard go to **Systems > Inverter System > Configure System**.

For expert users it is possible to change the inverters DC Input group and bay ID, shelf ID, and slot ID.

To configure inverter values manually:

1. Go to **Systems > AMPS HP2 Inverter System > Inventory > Inverters > Status** and select the **GO TO** button for the inverter.
2. In the **Inverter Mapping** table, set the **Bay ID** and **Shelf ID** and **Slot ID** to the desired values.
3. Launch the **Change DC Input Group** wizard and follow the steps.

7.7. Configure the bypass switch

The inverter system can have one or more bypass switches. The bypass switch will raise an alarm when the inverter system goes into bypass mode.

If there is more than one bypass switch, then the inverter system will go into bypass mode when any of the bypass switches are activated. During creation of the inverter system a default bypass switch is created. If a physical bypass switch does not exist, the bypass switch should be removed from the system.

7.7.1. Configure a basic bypass switch

The following describes how to configure a basic bypass switch. If the site is equipped with an XMBS bypass switch, see the following section.

To configure the basic bypass switch:

1. Go to **Systems > Inverter System > Inventory > Breakers, Fuses and Bypass Switches**. Select the **Add Bypass Switch** button. If a bypass switch exists, but needs to be removed, select **Remove**.
2. Select the **GO TO** button of the bypass switch to configure.
3. In the **Bypass Switch** table, set the **Name**, **Description** and **Input Source** values. When the value of digital input source is **Active**, bypass is in the **Bypass** state. When it is Inactive, the bypass is in the **Inverter** state. Alternatively, select the **Configure Bypass Switch** wizard to be prompted for the essential configuration required for the bypass switch to function.
4. In the **Alarms** table, select the **GO TO** button of the **Bypass Active** alarm and configure as required.

7.7.2. Configure an XMBS bypass switch

To configure the XMBS bypass switch:

1. Go to **Systems > Inverter System > Inventory > Breakers, Fuses & Bypass Switches**. Select the **Add Bypass Switch with XMBS support** wizard.
2. In the wizard, determine whether signals such as the switch's bypass state will be transmitted via CAN or hardwired I/O. CAN Signals is the recommended connection type when available. The CAN Signals connection type is not supported on XMBS (hardware revision 1) devices.
3. After finishing the wizard, select the **GO TO** button of the bypass switch to configure.
4. If the XMBS bypass switch signals are to be transmitted via Hardwired I/O, select the **Configure XMBS Hardwired Signals** wizard if it has not been configured already.
5. In the **Alarms** table, select the **GO TO** button of each alarm and configure as required.
6. If the inverter system has an internal bypass switch, Go to **Systems > Inverter System > Configure System** and map the **Internal Bypass Switch** entry appropriately. This allows the controller to inform the XMBS bypass switch of the internal byass switch's position when signals are to be transmitted via CAN; this is important so that the XMBS bypass switch can determine if it is interlocked (when the XMBS bypass switch is in inverter state, but the internal bypass switch is in bypass state).

Figure 7-3 A fully configured XMBS bypass switch with hardwired I/O signals

Bypass Switch		XMBS Interface		Alarms																																																							
<p>CONFIGURE XMBS HARDWIRED SIGNALS</p> <p>REMOVE</p> <table border="1"> <thead> <tr> <th>Name</th> <th>Value</th> </tr> </thead> <tbody> <tr> <td>Name</td> <td>XMBS with Hardwired I/O Signals</td> </tr> <tr> <td>Description</td> <td>---</td> </tr> <tr> <td>State</td> <td>Inverter</td> </tr> <tr> <td>XMBS Module</td> <td>MP9020-10-001</td> </tr> <tr> <td>XMBS Module Shortcut</td> <td>MP9020-10-001</td> </tr> <tr> <td>Switch Position Input</td> <td>Inactive</td> </tr> <tr> <td>Switch Position Input Source</td> <td>XMBS in Bypass (D3) : Helper ADIO (376015161)</td> </tr> </tbody> </table>		Name	Value	Name	XMBS with Hardwired I/O Signals	Description	---	State	Inverter	XMBS Module	MP9020-10-001	XMBS Module Shortcut	MP9020-10-001	Switch Position Input	Inactive	Switch Position Input Source	XMBS in Bypass (D3) : Helper ADIO (376015161)	<table border="1"> <thead> <tr> <th>Name</th> <th>Value</th> </tr> </thead> <tbody> <tr> <td>Utility-Inverter Sync Requested</td> <td>No</td> </tr> <tr> <td>Status Of Last Sync Request</td> <td>---</td> </tr> <tr> <td>Internal Bypass Relay</td> <td>Normal, Not Energized (N.C. contacts closed)</td> </tr> <tr> <td>Inverters Input Breaker State</td> <td>Closed</td> </tr> <tr> <td>Utility-Inverter Sync Requested Source</td> <td>Sync Request (D2) : Helper ADIO (376015161)</td> </tr> <tr> <td>Bypass Hardware Fault Source</td> <td>XMBS Fault (D1) : Helper ADIO (376015161)</td> </tr> <tr> <td>Internal Bypass In Bypass Relay</td> <td>Internal Bypass (K1) : Helper ADIO (376015161)</td> </tr> <tr> <td>Inverters Input Breaker Source (optional)</td> <td>Inverter Input Breaker (D4) : Helper ADIO (376015161)</td> </tr> </tbody> </table>		Name	Value	Utility-Inverter Sync Requested	No	Status Of Last Sync Request	---	Internal Bypass Relay	Normal, Not Energized (N.C. contacts closed)	Inverters Input Breaker State	Closed	Utility-Inverter Sync Requested Source	Sync Request (D2) : Helper ADIO (376015161)	Bypass Hardware Fault Source	XMBS Fault (D1) : Helper ADIO (376015161)	Internal Bypass In Bypass Relay	Internal Bypass (K1) : Helper ADIO (376015161)	Inverters Input Breaker Source (optional)	Inverter Input Breaker (D4) : Helper ADIO (376015161)	<table border="1"> <thead> <tr> <th>Name</th> <th>Status</th> <th>Limit</th> <th>Priority</th> <th>Relay</th> </tr> </thead> <tbody> <tr> <td>Bypass Active</td> <td>Inactive</td> <td>Minor</td> <td>---</td> <td>TEST ALARM</td> </tr> <tr> <td>Bypass Hardware Fault</td> <td>Inactive</td> <td>Minor</td> <td>---</td> <td>TEST ALARM</td> </tr> <tr> <td>Utility-Inverter Sync Request Fault</td> <td>Inactive</td> <td>Minor</td> <td>---</td> <td>TEST ALARM</td> </tr> </tbody> </table>		Name	Status	Limit	Priority	Relay	Bypass Active	Inactive	Minor	---	TEST ALARM	Bypass Hardware Fault	Inactive	Minor	---	TEST ALARM	Utility-Inverter Sync Request Fault	Inactive	Minor	---	TEST ALARM
Name	Value																																																										
Name	XMBS with Hardwired I/O Signals																																																										
Description	---																																																										
State	Inverter																																																										
XMBS Module	MP9020-10-001																																																										
XMBS Module Shortcut	MP9020-10-001																																																										
Switch Position Input	Inactive																																																										
Switch Position Input Source	XMBS in Bypass (D3) : Helper ADIO (376015161)																																																										
Name	Value																																																										
Utility-Inverter Sync Requested	No																																																										
Status Of Last Sync Request	---																																																										
Internal Bypass Relay	Normal, Not Energized (N.C. contacts closed)																																																										
Inverters Input Breaker State	Closed																																																										
Utility-Inverter Sync Requested Source	Sync Request (D2) : Helper ADIO (376015161)																																																										
Bypass Hardware Fault Source	XMBS Fault (D1) : Helper ADIO (376015161)																																																										
Internal Bypass In Bypass Relay	Internal Bypass (K1) : Helper ADIO (376015161)																																																										
Inverters Input Breaker Source (optional)	Inverter Input Breaker (D4) : Helper ADIO (376015161)																																																										
Name	Status	Limit	Priority	Relay																																																							
Bypass Active	Inactive	Minor	---	TEST ALARM																																																							
Bypass Hardware Fault	Inactive	Minor	---	TEST ALARM																																																							
Utility-Inverter Sync Request Fault	Inactive	Minor	---	TEST ALARM																																																							

Figure 7-4 A fully configured XMBS bypass switch with CAN signals

Bypass Switch		XMBS Interface		Alarms																																																							
<p>CONFIGURE XMBS HARDWIRED SIGNALS</p> <p>REMOVE</p> <table border="1"> <thead> <tr> <th>Name</th> <th>Value</th> </tr> </thead> <tbody> <tr> <td>Name</td> <td>XMBS with Hardwired I/O Signals</td> </tr> <tr> <td>Description</td> <td>---</td> </tr> <tr> <td>State</td> <td>Inverter</td> </tr> <tr> <td>XMBS Module</td> <td>MP9020-10-001</td> </tr> <tr> <td>XMBS Module Shortcut</td> <td>MP9020-10-001</td> </tr> <tr> <td>Switch Position Input</td> <td>Inactive</td> </tr> <tr> <td>Switch Position Input Source</td> <td>XMBS in Bypass (D3) : Helper ADIO (376015161)</td> </tr> </tbody> </table>		Name	Value	Name	XMBS with Hardwired I/O Signals	Description	---	State	Inverter	XMBS Module	MP9020-10-001	XMBS Module Shortcut	MP9020-10-001	Switch Position Input	Inactive	Switch Position Input Source	XMBS in Bypass (D3) : Helper ADIO (376015161)	<table border="1"> <thead> <tr> <th>Name</th> <th>Value</th> </tr> </thead> <tbody> <tr> <td>Utility-Inverter Sync Requested</td> <td>No</td> </tr> <tr> <td>Status Of Last Sync Request</td> <td>---</td> </tr> <tr> <td>Internal Bypass Relay</td> <td>Normal, Not Energized (N.C. contacts closed)</td> </tr> <tr> <td>Inverters Input Breaker State</td> <td>Closed</td> </tr> <tr> <td>Utility-Inverter Sync Requested Source</td> <td>Sync Request (D2) : Helper ADIO (376015161)</td> </tr> <tr> <td>Bypass Hardware Fault Source</td> <td>XMBS Fault (D1) : Helper ADIO (376015161)</td> </tr> <tr> <td>Internal Bypass In Bypass Relay</td> <td>Internal Bypass (K1) : Helper ADIO (376015161)</td> </tr> <tr> <td>Inverters Input Breaker Source (optional)</td> <td>Inverter Input Breaker (D4) : Helper ADIO (376015161)</td> </tr> </tbody> </table>		Name	Value	Utility-Inverter Sync Requested	No	Status Of Last Sync Request	---	Internal Bypass Relay	Normal, Not Energized (N.C. contacts closed)	Inverters Input Breaker State	Closed	Utility-Inverter Sync Requested Source	Sync Request (D2) : Helper ADIO (376015161)	Bypass Hardware Fault Source	XMBS Fault (D1) : Helper ADIO (376015161)	Internal Bypass In Bypass Relay	Internal Bypass (K1) : Helper ADIO (376015161)	Inverters Input Breaker Source (optional)	Inverter Input Breaker (D4) : Helper ADIO (376015161)	<table border="1"> <thead> <tr> <th>Name</th> <th>Status</th> <th>Limit</th> <th>Priority</th> <th>Relay</th> </tr> </thead> <tbody> <tr> <td>Bypass Active</td> <td>Inactive</td> <td>Minor</td> <td>---</td> <td>TEST ALARM</td> </tr> <tr> <td>Bypass Hardware Fault</td> <td>Inactive</td> <td>Minor</td> <td>---</td> <td>TEST ALARM</td> </tr> <tr> <td>Utility-Inverter Sync Request Fault</td> <td>Inactive</td> <td>Minor</td> <td>---</td> <td>TEST ALARM</td> </tr> </tbody> </table>		Name	Status	Limit	Priority	Relay	Bypass Active	Inactive	Minor	---	TEST ALARM	Bypass Hardware Fault	Inactive	Minor	---	TEST ALARM	Utility-Inverter Sync Request Fault	Inactive	Minor	---	TEST ALARM
Name	Value																																																										
Name	XMBS with Hardwired I/O Signals																																																										
Description	---																																																										
State	Inverter																																																										
XMBS Module	MP9020-10-001																																																										
XMBS Module Shortcut	MP9020-10-001																																																										
Switch Position Input	Inactive																																																										
Switch Position Input Source	XMBS in Bypass (D3) : Helper ADIO (376015161)																																																										
Name	Value																																																										
Utility-Inverter Sync Requested	No																																																										
Status Of Last Sync Request	---																																																										
Internal Bypass Relay	Normal, Not Energized (N.C. contacts closed)																																																										
Inverters Input Breaker State	Closed																																																										
Utility-Inverter Sync Requested Source	Sync Request (D2) : Helper ADIO (376015161)																																																										
Bypass Hardware Fault Source	XMBS Fault (D1) : Helper ADIO (376015161)																																																										
Internal Bypass In Bypass Relay	Internal Bypass (K1) : Helper ADIO (376015161)																																																										
Inverters Input Breaker Source (optional)	Inverter Input Breaker (D4) : Helper ADIO (376015161)																																																										
Name	Status	Limit	Priority	Relay																																																							
Bypass Active	Inactive	Minor	---	TEST ALARM																																																							
Bypass Hardware Fault	Inactive	Minor	---	TEST ALARM																																																							
Utility-Inverter Sync Request Fault	Inactive	Minor	---	TEST ALARM																																																							

7.8. Configure the breaker or fuse

The inverter system can have one or more breakers and fuses. An alarm condition occurs when a breaker or fuse is open. When first creating an inverter system, two breakers and a fuse are created by default. They should be removed if not needed.

To configure a breaker or fuse:

1. Go to **Systems > Inverter System > Inventory > Breakers, Fuses and Bypass Switches**. Select the **Add Breaker or Fuse** button if needed. If a breaker or fuse switch exists, but needs to be removed, in the **Breakers and Fuses** table, select **Remove**.
2. Select the **GO TO** button of the breaker or fuse to configure.
3. In the **Configuration** table, enter the **Name**, **Description** and **Input Source** values. When the value of the input source is **Active**, the breaker or fuse is open. Alternatively, select the **Configure Breaker or Fuse** wizard to be prompted for the essential configuration required for the breaker or fuse to function.
4. In the **Alarms** table, select the **GO TO** button of the **Breaker/Fuse Open** alarm and configure as required.

8. Line power systems

This section provides an overview of line power converters, how they function, as well as how to configure a line power system.

8.1. Introduction to line power systems

The line power conversion modules in a line power system take a –48V nominal DC input voltage and converts it to a different output voltage. There are three types of line power modules:

- Cordex® HP LPS36 –48 Vdc to ±190 Vdc line power system
- Cordex® HP LPS36 ±137V line power system
- Cordex® HP eLimiter+ 57V distribution system

All three types have four independent output channels, each with a maximum output power of 100 watts. In a line power system (LPS) the output of the channels from different modules can be combined to supply power to loads at remote locations. Combining channels allows for supplying power to loads that may exceed the 100 watts limit of a single channel.

The two Cordex® HP LPS36 modules are designed for outdoor power applications that deliver power through existing copper telephone wires. The Cordex® HP eLimiter+ module is designed for indoor power applications that use larger gauge wire for power delivery.

 **Warning:** Working with line power modules, especially Cordex® HP LPS36 modules, pose potentially fatal safety concerns. Refer to the appropriate hardware manual before attempting to wire an line power system or to get more detailed information about the electrical performance of these modules.

8.1.1. Components of a line power system

Systems with Cordex® HP LPS36 modules are different than systems with Cordex® HP eLimiter+ distribution modules.

Cordex® HP LPS36 modules require down-converters at the remote end to convert the high voltage output to a nominal –48V which is suitable for most loads.

The output of the Cordex® HP eLimiter+ modules is already at –48V, so these systems do not require downconverters.

Refer to the following diagrams for the typical components of an line power system.

Figure 8-1 Example Cordex® HP LPS36 line power system

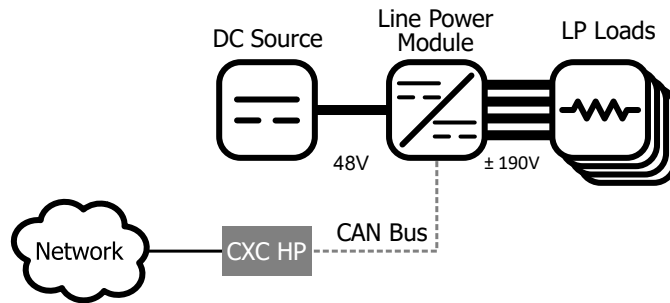
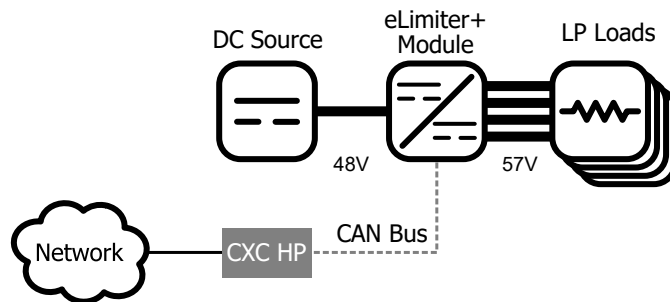



Figure 8-2 Example Cordex® HP eLimiter+ class 2 distribution system



 **Notice:** Due to the remote location of downconverter modules, they are not monitored by the controller.

8.1.2. Quick reference for configuring a line power system

Figure 8-3 Quick reference for configuring a line power system

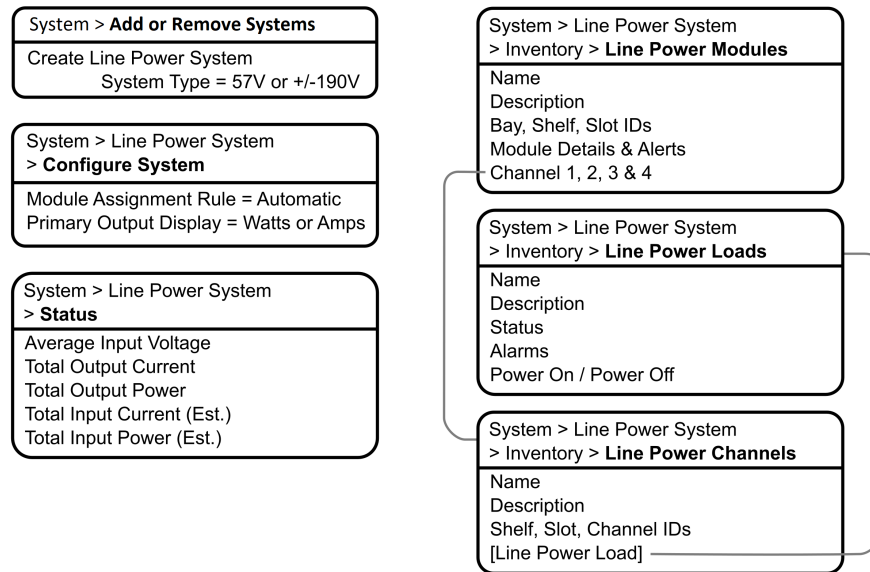

8.2. Create a line power system

There is no line power system on a new controller. You can create a new system from scratch or import one from a configuration file that contains a system from another controller. It is possible to create more than one line power system.

A new power system can be created from the controller LCD or the web interface, via the **Systems > Add or Remove Systems** menu. A wizard steps you through the process to create the new system. You can create three types of systems:

- Cordex® HP LPS36 ±190 Line Power System
- Cordex® HP LPS36 ±137 Line Power System
- Cordex® HP eLimiter+ Class 2 Distribution System

The new system will have a reasonable set of defaults and associated alarms where possible. Optional configurable values, such as Name, Description, and System Number, can be used to describe and organize your system.

You can configure the alarms associated with the Line Power system. You can enable or disable the alarms, change the priority, map relays to the alarms, and where applicable, modify the thresholds.

To create a line power system:

1. Go to **Systems > Add or Remove Systems** and select the **Create System** button.
2. Select **Create Line Power System** from the dropdown list. The **Create Line Power System** wizard will launch.
3. Name the system if required.
4. From the **Select System Type** dropdown list, select the value that corresponds to your line power module type. If there are line power modules already connected to the controller, they are preselected with the correct option.
5. Follow the rest of the wizard instructions.

8.2.1. Create a system from a configuration file

A system can be created by importing from a configuration file. See the *Importing a system* section for more information.

8.3. Configure the line power modules

There are two settings that are applied to all line power modules: **Input Voltage Low Shutdown** and **Input Voltage Low Restart**.

When the input voltage falls below the low shutdown threshold, the line power modules will power off all output channels. Set this threshold to a value that prevents over-discharge of the battery.

When the input voltage rises above the restart threshold, the units turn back on. The restart threshold must be at least two volts above the shutdown threshold or the **LP Module Configuration Error** alarm will activate (Cordex® HP LPS36 line power module only).

These settings are stored on the line power module itself which means that even if disconnected from the controller the line power modules will still perform in this way.

To configure the line power modules:

1. Go to **Systems > Line Power System > Configure System**.
2. In the **Configuration** table, set the **Input Voltage Low Shutdown** threshold to the desired value.
3. In the same table, set the **Input Voltage Low Restart** threshold to the desired value.

8.3.1. Shared alarm configuration

The **Shared Alarm Configuration** feature is a setting which can be used to enable/disable or change the priority of alarms on all line power modules in a system. When using this feature you can configure both the **Channel Shutdown** and the **Module Failure** alarms on the specific line power system being configured. Configuring **Channel Shutdown** will apply the setting to each of the four channel shutdown alarms on each line power system module.

8.4. Line power module alarms

Line power modules assigned to a system, report active alarms which are displayed on the details page of each specific module, and on the **Active Alarms** page. Line power module alarms function the same as regular alarms with the exceptions of shared configuration, as detailed in the previous section.

Each line power module has four channel alarms and a **Module Failure** alarm.

A **Module Failure** indicates a module-level failure such as, input voltage, high/low, high temperature, or if the module has lost communication.

A **Channel Shutdown** is activated if any channel shutdown alert such as, over voltage and ground fault, are active.

Both channel and module alarms provide an SNMP notification that identifies the alert/condition which produced the alarm, and the physical location of the module (bay-shelf-slot-channel).

8.5. Configure the line power system channels

Each line power module has four channels that can be given a name, description and assigned to a load. All channels are listed in table that can be sorted and searched. You can also export all channel details to a file.

To configure LPS channels:

1. Go to **Systems > Line Power System > Inventory > Line Power Channels**. You will see a table of channels in the system. There is also a **Export Channel Details** button to export the information to a CSV file.

Channels cannot be added or removed. It is also possible to configure channels and get detailed channel information from **Systems > Line Power System > Inventory > Line Power Modules** and select the **GO TO** button for the module.

2. Select the **GO TO** button for the channel you want to configure.
3. In the channel table, assign an optional name and description. This might be a channel address, wire color, or customer name.
4. In the channel table, assign an optional **Line Power Load**. To assign a load it is necessary to first create a load. Refer to **Configure the Line Power Loads**.

8.6. Configure the line power system loads

A line power load represents the remote load that is powered by the line power module channels. Create a load when you want to monitor and alarm separate remote loads. Creating a load allows all channels that have been assigned to the load to be powered on or off as a group. To turn all the channels assigned to a load on or off, use the **Power On** or **Power Off** buttons on the **Configuration** table.

You may add or remove loads as needed. Removing a load does not affect the power delivered.



Notice: To assign channels to a load, refer to the section on *Line power system layout* or *Configure line power system channels*.

To configure LPS loads:

1. Go to **Systems > Line Power System > Inventory > Line Power Loads**. You will see a table for loads in the system. This table shows how many channels are assigned to the load and the loads total output current and power. Add or remove loads from this screen.
2. Select the **GO TO** button for the load you want to configure.
3. In the **Configuration** table, assign the load a name and a description. We recommend that you assign the load a name that represents the actual load.
4. Configure the load alarms as needed.

8.7. Line power system layout

The line power system **Layout** screen shows a graphical view based on the shelf and slot ID as reported by the line power modules. This view allows a convenient way to view module status and to configure and interact with individual channels.

8.7.1. Use the layout screen to view module status

The line power **Layout** screen provides a convenient way to view:

- Module shelf and slot position
- Output voltage, power and current for each module
- Module and channel alert status
- Module and channel information (detailed)
- Load information (detailed)

How to use the Layout screen to view module and channel status:

1. Go to **Systems > Line Power System > Layout**. This screen shows a grid of line power modules organized by shelf ID vertically, and slot ID horizontally. Each module is represented by a rectangle showing the output voltage and the output power for each channel. The information in the rectangle is green to indicate that a module is operating normally.

It is possible to display channel output power or channel output current on this screen. Change the **Primary Output Display** to the desired value in the **System Properties** table at **Systems > Line Power System > Configure System**.

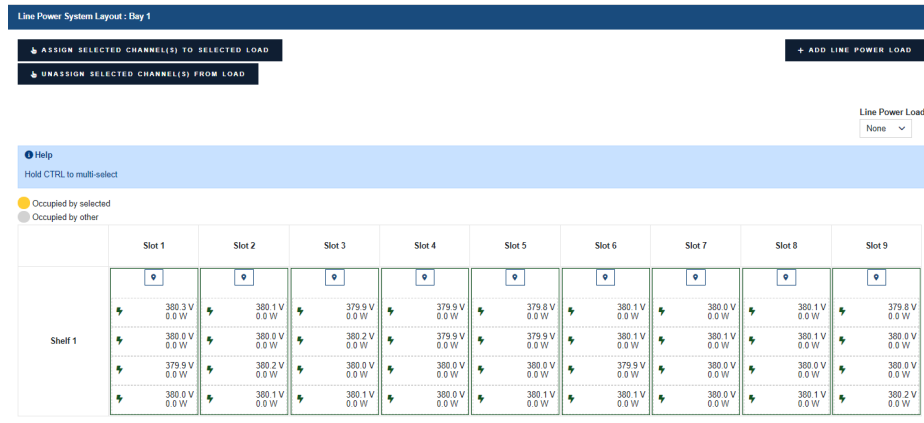

2. Select a channel for detailed information. If a module has an active alert then the green turns to red to indicate an alert with the module or with a channel. If the alert is on a specific channel then the specific channel will be highlighted red. If it is module alert only, then the channels will all show green but there will be red border around the module. To get more detail on the active alert, select the channel that has the alert (if it is a module alert select any channel that belongs to the module).
3. In the **Channel Details** table, select the **GO TO** button for the **Line Power Module** to view active alert information.
4. In the **Module Alerts** table sort by **Value** to bring the active alerts to the top of the table.

8.7.2. Use the layout screen to view load status

The following steps describe how to use the **Layout** screen to view load status.

1. Go to **Systems > Line Power System > Layout**.
2. Using the **Line Power Load** dropdown list, select a load. A table displays detailed information about the load. You can modify the name, description, and other information about the load as well as do all load management tasks from this page.

8.7.3. Use the layout screen to assign channels to loads

The line power **Layout** page provides a convenient way to:

- View which channels have been assigned to the Line Power Loads
- Assign channels to an Line Power Load
- Unassign channels from loads
- Add, remove, and rename loads

To use the Layout screen to view and configure channels assigned to Line Power Loads:

1. Go to **Systems > Line Power System > Layout**. At the top of the table use the dropdown list to select an Line Power load. When **None** is selected, the channels that are not assigned to a load display as highlighted.

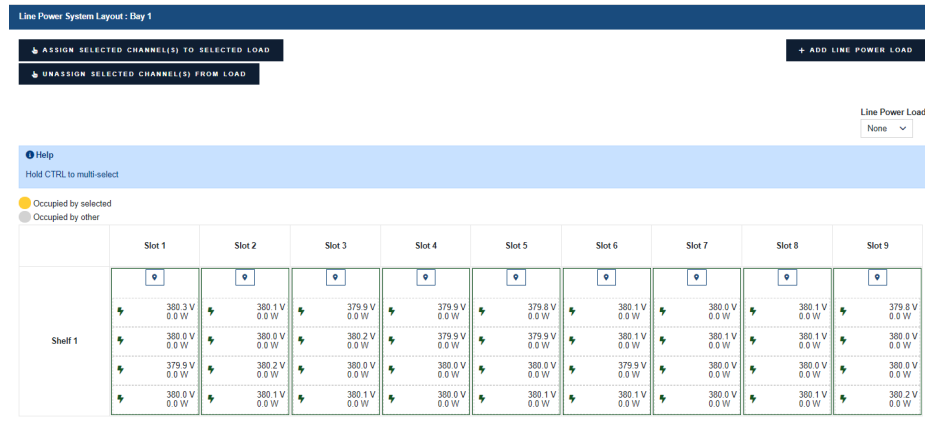

2. Select a load from the dropdown list. The channels assigned to this load will be highlighted.
3. To add a new channel to the load, select it. The channel rectangle will turn blue to indicate it is selected.
4. In the layout table, select **Assign Selected Channel(s) to Selected Load**. In the channel details table, the **Line Power Load** field will be populated with the name of the load.

By default, the **Assign Selected Channel(s) to Selected Load** and **Unassign Selected Channel(s) from Load** buttons are disabled unless a load and channels are selected.

5. To unassign a channel from the load, select a highlighted channel, and then select **Unassign Selected Channel(s) from Load**. In the channel details table, the **Line Power Load** field will be set to "--".
6. To assign or unassign multiple channels at once, hold **CTRL** on the keyboard and select the required channels which display as blue when selected.
7. Once all required channels are selected, use the **Assign Selected Channel(s) to Selected Load** or **Unassign Selected Channel(s) from Load** buttons to assign and unassign multiple channels.

8.8. Line power channels import

The line power channel import provides the ability to map line power channels to line power loads which are created on import for a line power system. This is achieved using a comma separated values (CSV) file which is filled in by the user.

The import will automatically remove pre-existing line power loads and channel assignments if the provided import file is valid. After removal, newly created inventory and configuration is added based on the file being imported.

The *Export line power channels* section will describe how to get started.

8.8.1. Export line power channels

Pre-ample: A line power connection in the controller is the shelf, slot, and channel together which indicates its physical position in the system. The total connections on a controller for a line power system is based on the maximum shelves (9) × maximum slots (12) × maximum channels (4), for a grand total of 432 total connections if modules are inserted in all shelves and slots.

How to export: with a line power system created and modules assigned to the system, a user can go to **Systems > Line Power System > Inventory > Line Power Channels** and select the **Export Channel Details** button to export a CSV file with all the currently existing line power connections available. The exported connections are based on the modules acquired for the line power system.

The sections: (1) 'Sort Exported Line Power Channels' will help sort the line power connections in Microsoft Excel as the file rows will be out of order and sorting will make it easier to enter data. (2) 'Enter data into a Line Power Channels File' will help populate the exported CSV file empty cells.

8.8.2. Sort exported line power channels

After export, a user can open the file in a CSV editing program such as Microsoft Excel. In Excel, for better readability, it is always recommended to sort the data presented as the Shelf/Slot/Channel data columns will be out of order. After sorting the data, a user can start entering the required data in sequential order for what channel belongs to which load.

To sort channel data in Microsoft Excel:

1. Highlight all the available data.
2. Select the **Data** tab.
3. Select **Sort** within the **Data** tab.
4. In the Sort Window, add the "Shelf" column for **Sort By** using the dropdown list. Additionally, verify the **Sort On** value is "Cell Values" and the **Order** value is "A to Z".
5. In the Sort Window, select the **Add Level** button.
6. In the Sort Window, for the new level, add the "Slot" column for **Sort By**.
7. Select **Ok** in the Sort Window to view the data in sequential order.
8. After sorting, follow section 'Enter data into a Line Power Channels File' for details on what to enter into the empty CSV file cells.

8.8.3. Enter data into a line power channels file

When opening the line power channels CSV file, there are multiple columns with headings. Some columns are not to be changed, some are recommended to enter, and some are required to be filled in.

Fill in the empty CSV cells based on the information below.

Figure 8-4 A non-filled sorted line power channels CSV file

	A	B	C	D	E	F	G	H	I
1	Shelf	Slot	Channel	Channel Name	Channel Description	Module	Load Name	Load Description	Downstream Loads
2	1	1	1						
3	1	1	2						
4	1	1	3						
5	1	1	4						
6	1	2	1						
7	1	2	2						
8	1	2	3						
9	1	2	4						

1. Column cells that should not be changed in the CSV file

The Shelf, Slot, and Channel columns should not be modified as they are the possible connection values on the system which will be assigned to a line power load. These values are automatically populated when the line power channels template is used or the channels file is exported.

- The **Shelf** column corresponds to the shelf which the line power module is inserted.
- The **Slot** column corresponds to the slot on the shelf that the line power module is inserted.
- The **Channel** column corresponds to the channel in the slot that the line power module is inserted.
- The **Module** column will be empty if the line power channels template is used and it will be filled in with the module serial number if the channels file was exported from the controller.

2. Column cells which are recommended to be changed in the CSV file

All recommended entries will be imported if a value is entered in the CSV cell associated with the line power channel but will not affect channel to line power load assignment.

- The **Channel Name** can be entered with a suitable name.
- The **Channel Description** can be entered with a suitable description.
- The **Load Description** can be entered with a suitable description.
- Downstream Loads** that are linked to a line power load can be entered. The downstream loads are based on the **Load Name**. If the **Load Name**, is the same for multiple channels the downstream loads entry must be the same as well.

An example of a downstream load is a radio powered by a line power down-converter. The down-converter can be made to be the line power load in the line power system. There can be many radio loads linked to one line power load (down-converter) which provides the flexibility to enter those names into **Downstream Loads** column.

3. Column cells that is required to be modified in the CSV file

To create a load and assign a channel to a Load, the **Load Name** must be entered for each channel

To assign multiple channels to the same line power load, a user may enter the same **Load Name** for each respective channel.

4. After the required information has been filled in

After modification of the file and saving it. Follow section 'Import a Line Power Channels File' for guidance on importing the file.

8.8.4. Import a line power channels file



Notice: *If there are line power loads and channels that already exist on the line power system, then it is always recommended to export those channels as a backup just in case the system configuration needs to be reverted. Go to **Systems > Line Power System > Inventory > Line Power Channels** and pressing the **Export Channel Details** button. The exported file then can be re-imported later to return to that configuration if required.*

After modifying the line power channels CSV file, go to **Systems > Line Power System > Inventory > Line Power Channels** and select the **Import configuration from CSV** button. Upon successful import, verify that the system configuration is correct based on the imported CSV file.

Follow the following sections: (1) 'Verify a Line Power Channel Import' for tips on validating an imported CSV file and (2) 'Line Power Channels File Import Errors' to troubleshoot errors that may have been encountered on the import process.

8.8.5. Verify a line power channel import

After a successful import, it is always recommended to check against the file imported to what now exists on the system.

Line power channels and loads

In **Systems > Line Power System > Inventory > Line Power Channels** table. The values in this table will be filled based on the imported CSV file with each channel assigned to an expected line power load. This table can be used to verify the values entered in the CSV file match the expected system configuration.

Additionally, the **Systems > Line Power System > Inventory > Line Power Loads** table can be used to check the line power loads created and the number of channels assigned are correct.

Line power layout page

A secondary way to verify an imported CSV file is to go to the **Systems > Line Power System > Layout** page. This page serves as a all-in-one page to display the physical layout of a line power system. Additional information about the **Line Power Layout** page can be found in the section detailed Line Power System Layout.

In this table, selecting **Line Power Load** and selecting the **Load Name** in the dropdown list will highlight the channels associated with that load. A user can go through each load one-by-one using the CSV for reference to observe if assignment is correct.

For additional information on for the line power layout, visit the *Line power layout* section of this manual which describes the layout in more detail.

9. Auxiliary systems

This section provides an overview of the auxiliary system and how it is configured.

9.1. Introduction to auxiliary systems

The auxiliary system serves as a standalone system for monitoring the readings on a current or other transducer. Both AC or DC current transducers can be used.

The typical application for this type of system is to monitor current flowing through the AC feeds into a site or a power system.

9.2. Create an auxiliary system

To create an auxiliary system:

1. Go to **Systems > Add or Remove Systems** and select the **Create Auxiliary System** button.
2. Go to **Systems > Auxiliary System > Configure System** and enter a **Name** and **Description** for the system.

9.2.1. Create a system from a configuration file

A system can be created by importing from a configuration file. See the *Importing a system* section for more information.

9.3. Current transducers

The physical current transducer can be of the voltage-output type (0 to 5 V or 0 to 10 V) or current-output type (4 to 20 mA) type depending on the accuracy requirements. A 4 to 20 mA type is more accurate because losses in the sensor leads are inherently compensated.

A transducer with a voltage output can be connected directly to a Cordex® CXC HP L-ADIO peripheral voltage input. A transducer with 4 to 20 mA output must have a 500R resistor added across the voltage input. For AC, the current transducer must be of the type which conditions the signal to provide a DC output proportional to the RMS (or average) value. AC waveforms cannot be monitored by the Cordex® CXC HP L-ADIO peripheral input circuitry due to noise filtering.

9.4. Configure the current transducer

The system, by default does not contain any current transducers. You can add or remove current transducers as needed. To configure a current transducer you need a voltage input on an ADIO module. To configure a current transducer with an Cordex® CXC HP CT-IPM module, you need a shunt input on an ADIO module.

To configure a current transducer:

1. Go to the system where you want to add the transducer and navigate to the inventory page. Go to **Systems > DC System > Inventory > Other Transducers**. In the **Other Transducers** table, there will be a list of current transducers in the system. Add or remove them from this page.

You may be using a current transducer with **Interface & Power Module (IPM)**. This device takes the voltage reading from a current transducer and divides the reading by 50. The factored voltage reading is then sent to the Cordex® CXC HP L-ADIO peripheral shunt input.

2. Select the **GO TO** button for the **Current Transducer** you wish to configure.
3. In the **Configuration** table, select **Configure Current Transducer** to launch the wizard and complete each step to configure the transducer.
4. Enter the **Measurement Range** in amps.
5. Enter the **Range in Volts**.
6. Select **CT Current Source**. This can be any voltage source.
7. Optional: enter the **Offset** calibration for the **Current Transducer** if the reading error is too low or high.

9.5. Configure the general purpose transducer

The system, by default does not contain any general purpose transducers. You can add or remove general purpose transducers as needed. To configure a general purpose transducer you need a voltage input on an ADIO module.

To configure a general purpose transducer:

1. Go to the system where you want to add the transducer and navigate to the inventory page. Go to **Systems > DC System > Inventory > Other Transducers**. In the **General Purpose Transducers** table, there will be a list of general purpose transducers in the system. Add or remove them from this page.
2. Select the **GO TO** button for the **General Purpose Transducer** you want to configure.
3. In the **Configuration** table assign a name and a description.
4. Select **Transducer Input Source**. This can be any voltage source or a custom data.
5. Enter the **Transducer Input Minimum in Volts** and **Transducer Input Maximum in Volts**.
6. Enter the **Transducer Output Minimum** and **Transducer Output Maximum**.
7. Select **Units and Precision**.
8. **Optional:** Enter the **Offset** calibration for the calculated **Value** if the reading error is too low or high.

The **Calculated Slope** and the **Offset** are used to convert the **Input Source Value** to the **Value**. The value is displayed in the selected units and precision.

10. Distribution systems

This section provides an overview of the operation and configuration of a distribution system and its subsystems, panels, and breakers.

10.1. Introduction to distribution systems

A distribution system is a way to define and track how the output power of a DC system is distributed. The system may be composed of specialized ADIO modules built for the purpose of distribution or via general-purpose ADIO modules in any configuration. The distribution system itself is really just a “container” to hold distribution subsystems.

In the case of the specialized ADIO modules (a smart subsystem), the subsystem will map one-to-one with the ADIO module. For example, a Cordex® Smart BDFBi ADIO module will be represented in the distribution system as one subsystem. Manually created subsystems can be mapped to a number of ADIO modules, and contain a user-defined number of breaker/fuse panels and breakers themselves.

Within a subsystem there are a number of panels. A panel is a grouping of breakers/fuses.

A panel is considered a ‘downstream load’ of a subsystem and a breaker/fuse is considered a ‘downstream load’ of a panel. A breaker can then feed a referenced load. For example, a breaker may feed a DC system or another subsystem. In this way, a user can create primary and secondary distribution layouts. Understanding this relationship helps to visualize how a distribution system, its subsystems, panels, breakers or fuses, and referenced loads are organized.

A manually defined subsystem may contain up to 160 breakers across all panels. This could consist of 160 panels with one breaker each, 10 panels with 16 breakers each, or another combination. The smart subsystems will contain the number of panels and breakers supported by the ADIO module type to which they correspond.

Figure 10-1 Example of a DC system distribution system

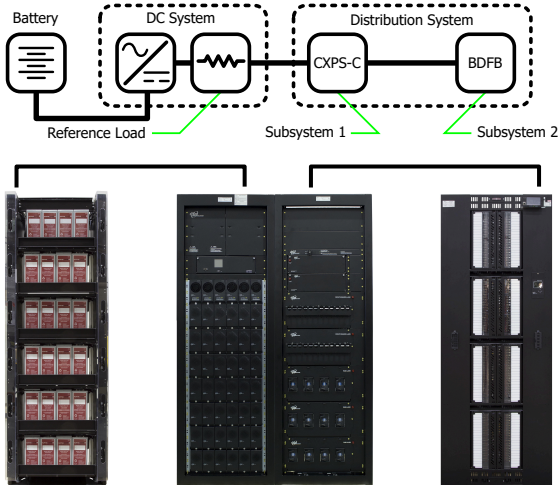

10.2. Create a distribution system

There is no distribution systems on a new controller. Creating distribution systems is done via the **Create System** button located under the **Systems > Add or Remove Systems** menu. There is no configuration required at the system level.

You can also import a distribution system via a configuration file.

The controller supports multiple distribution systems. We recommend using multiple distribution systems to separate the distribution of different voltage levels. For example, a user can create a 48 V distribution system, and a 24 V distribution system. Multiple systems could also be used in different ways, such as to separate primary and secondary distribution, or even physical layouts such as “first floor distribution” and “second floor distribution”.

When first created, a distribution system is empty. Subsystems must be added to give the system meaning. The system-wide voltage and current readings are **Unknown** when the subsystem is first created. These values are mapped to sources via the **Systems > Distribution System > Configure System** page. By default, the **Voltage Source** is set to **Average All External Input Voltages** and the **Current Source** is set to **Sum All External Input Currents**.

External inputs, as mentioned, mean inputs external to the Distribution System. Only subsystems that are mapped as a referenced load in another system will be used to create system summary values by default. This provides the opportunity to nest layers of subsystems within the same distribution system, and have the system summary values computed properly. If a different behavior is required, the voltage and current sources can be edited to sum or average all subsystems, or to point to any other voltage and current sources available on the controller, including Custom Data.

To create a distribution system:

1. Go to **Systems > Add or Remove Systems** and select the **Create System** button.
2. Select **Create Distribution System** from the dropdown list of systems.
3. A system is immediately added to the **Inventory** table.
4. Go to **Systems > Distribution System > Configure System** and enter a **Name**, **Description** and any other identifying information required.

10.2.1. Create a system from a configuration file

A system can be created by importing from a configuration file. See the *Importing a system* section to do this.

10.3. Distribution subsystems

Once a distribution system exists, at least one subsystem must be added. This is done via the **Systems > Distribution System > Subsystems** menu on the web interface or LCD. There are two types of subsystems: **Smart Distribution Subsystem** or **User Defined Subsystem**. Each type uses a wizard to assist in creating and configuring a subsystem.

Generally a subsystem will correspond to a physical rack on the site. Subsystems that distribute power from the same source should all be contained within the same distribution system. Multiple distribution systems are possible, but should only be used if the representation of multiple distributions systems is required.

For example, distribution equipment such as on different two different floors, may be better represented by two distributions system rather than one.

The following sections describe the different subsystems and information on creating them.

10.4. Create a smart subsystem

A smart subsystem correlates one-to-one with a “smart” distribution ADIO module, such as the Smart BDFB or the Smart E2 distribution subsystems. The number of panels and breakers supported by that ADIO module are created automatically. During the wizard set up, you can map the ADIO module for the subsystem. This can also be done later if the ADIO module is not available when the system is created. The smart subsystem will not function properly until the correct type of ADIO module is assigned.

In the first step of the wizard, there is an option to name the subsystem. The current smart distribution subsystems are the Smart BDFB or the Smart E2. From the list of ADIO modules currently acquired by the controller, you can choose the ADIO module for this subsystem, or it can be done later via the **Systems > Distribution System > Subsystem > ADIO** page. Once an ADIO module is selected, you can choose to “locate” the ADIO module to ensure it is correct. It is also possible to give a custom name to the ADIO module so that it is easily recognized in the **Modules > All Modules** list.

In a smart subsystem, inventory is automatically created based on the system type. For example, a Smart BDFB distribution subsystem supports eight panels with 20 breakers per panel, and a Smart E2 distribution subsystem has two panels with 11 breakers. The ADIO module inputs to panels and breakers are also mapped automatically.

A smart subsystem gets all available information from its associated ADIO module. For each panel, the current and voltage are measured by the ADIO module, as well as any active alarms. On the Smart BDFB subsystem, one breaker trip signal is available per panel. This means that the subsystem knows, at the panel level, that one or more of the 20 breakers associated with that panel are tripped, but not which particular breakers. On the Smart E2 subsystem, the individual breaker trip signals are provided by the ADIO module, so they can be displayed at the breaker level.

The Smart BDFB subsystem also has the ability to have its panels set up as “linked” to other panels, or “blank” if unused. This information can be viewed from the **Systems > Distribution System > Subsystem > Panel** page.

The Smart E2 subsystem has a temperature alert, which other ADIO module types do not. There is a field called **Over Temperature Alert** in the subsystem, which is only populated for Smart E2-based subsystems.

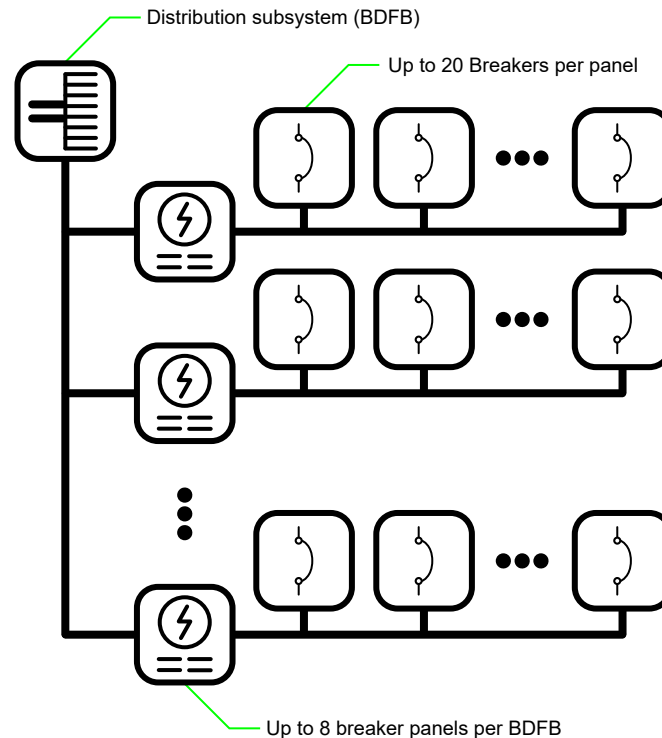
Figure 10-2 Example of BDFB distribution subsystem**To create a smart distribution subsystem:**

1. Go to **Systems > Distribution System > Subsystems**, and then select **Create Smart Distribution Subsystem**. Follow the wizard.

You can now view the **Smart Distribution Subsystem** from the **Distribution Subsystems** table. No further configuration is necessary. If you plan to reconfigure the smart ADIO module, continue with the following steps.

2. Go to the **Systems > Distribution System > Subsystem > ADIO** menu.
3. Select the **GO TO** button of the assigned ADIO module to view all its details including configuration and I/O. (Ensure there is an ADIO module assigned to the system first.)
4. In the **Configuration File** table use the **Upload Configuration file to Controller** and **Get Configuration File from ADIO** buttons to send the configuration to the ADIO module.

10.5. Create a user defined subsystem

Any type of distribution that is not a smart subsystem is called a user defined subsystem. The user can specify the number of panels, breakers or fuses, and shunts, and then quickly bulk-map the ADIO module inputs to shunt sources.

The first step of the wizard there is an option to name the subsystem. Next, specify the number of breaker or fuse panels to create. There is a limit of 160 breakers across all the panels. This could consist of 160 panels with one breaker each, 10 panels with 16 breakers each, or some other combination. There is an option to name each panel, specify the number of breakers or fuses, and specify the shunt configuration. When finished you can still add or remove panels, breakers and shunts via their respective pages in the subsystem tree. After panels, breakers and shunts have been added, specify the ranges of all the shunts in the subsystem. These can be changed later via the **Shunts** table.

Figure 10-3 Example of a user defined subsystem

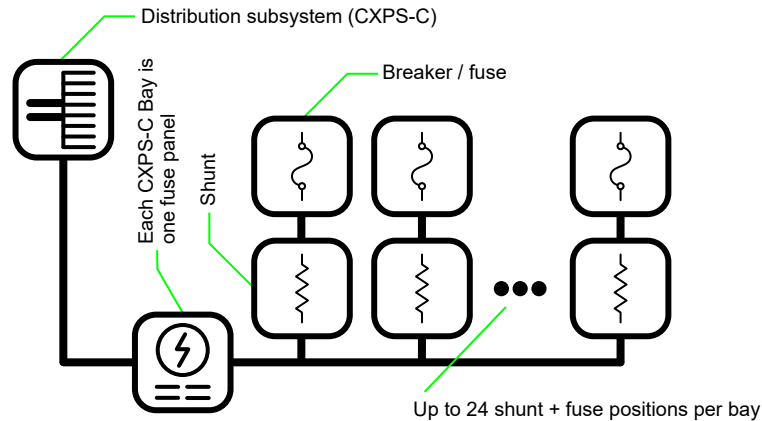

To create a user defined subsystem:

1. Go to **Systems > Distribution System > Subsystems**, select **Create User Defined Subsystem**, and then follow the wizard.
2. In the **Distribution Subsystems** table, select the **GO TO** button to view the subsystem.
3. If you need to map the shunt sources, go to **Systems > Distribution System > Subsystems > Subsystem > Shunts**, select **Map Shunts to ADIO Inputs**, and then follow the wizard.
4. Shunts and Breakers/Fuses can be removed from any of the tables where these are listed in the Subsystem. However, because the Subsystem needs to know the parent panel when adding new Shunts or Breakers/Fuses, they can only be added from the **Systems > Distribution System > Subsystems > Subsystem > Subsystem Details > Downstream Loads > Panel > Shuntstable**.

10.6. Configure the panel details

A panel is a grouping of breakers or fuses within a subsystem. A panel is considered a downstream load of a subsystem. On smart subsystems, these are automatically created according to the number of panels that the ADIO module supports. For BDFB distribution subsystems, the full eight panels are created, even though some may be linked or blank. For Smart E2 distribution subsystems, two panels are created. On a user defined subsystem, you can add up to ten panels per subsystem.

To monitor a breaker or fuse trip associated with a panel, the **Breaker/Fuse Source** should be mapped to a digital input as well. Again, for smart subsystems, these values are automatically set based on the assigned ADIO module.

There are several text fields associated with a panel, which the user may find useful to further describe the panel, such as Description, Fuse Number, Fuse Size, and Fuse Maximum Amperage. These are optional and may be filled in by the user if desired.

There are three alarms provided on each panel: **Breaker Trip**, **Loss of Feed**, and **Over Current**. On a user defined subsystem, thresholds for these alarms are set as applicable. The **Breaker Trip** alarm is not a threshold alarm; it is calculated based on the **Breaker/Fuse Source** set for the panel. On a smart subsystem, alarms come directly from the ADIO module and thresholds must be set on the ADIO module.

A concept specific to the BDFB distribution system is linking panels. Panels may be linked up to the panel above, or linked down to the panel below, based on the loads. They may also be set blank if unused. When one or more panels are linked, one must still be designated as the shunt, and the others are configured as linked. The voltage and current measurements are taken from the shunt panel only. The breaker trips are still monitored on all linked panels. The configuration of panels as shunt, linked up, linked down, or blank must be done via the Cordex® Smart BDFBi ADIO module. The controller only reports the details.

To configure panel details:

1. Go to **Systems > Distribution System > Subsystems**, and select the **GO TO** button for the subsystem that contains the panels to configure.
2. Enter the **Subsystem Details** menu.
3. In the **Downstream Loads** table, select the **GO TO** button for the panel to configure.



Notice: Note that in smart subsystems, the configuration is done automatically via ADIO module.

4. In the **Configuration** table, edit the details of the panel.

10.7. Configure the breaker or fuse details

In a distribution system, a breaker or fuse represents a downstream load of a panel. Breaker/fuse configuration can be accessed directly under the subsystem, or from the panel in which it resides.

Within the Breaker/Fuse configuration, there are a number of text fields that can be used to better describe and define the breakers. These cannot be obtained from the ADIO module in any automatic way. They need to be configured manually. These fields include a **Description**, **Usage**, **Size**, **AWG**, and **Destination** field for each breaker. Manually editing all of these fields is a lot of work for large systems. The most effective way to do this is to download and edit the fields in spreadsheet format. This makes it easy to cut and paste, use macros, or reuse entered text for other purposes (such as printing labels).



Notice: The input source of the breaker is set automatically because the value is constrained by physical wiring on the panel. Although the field is editable, it will be set back to the correct value if it is manually changed. This is true for Smart E2 subsystems only.

To configure all breakers or fuses in a distribution subsystem:

1. Go to **Systems > Distribution System > Subsystems** and select the **GO TO** button for the subsystem that contains the breakers or fuses to configure.
2. Enter the **Breakers and Fuses** menu.
3. Select **Export to CSV** to download a file to the computer. Open this file in a spreadsheet program.

Alternatively, you can export a CSV file to configure just the breakers or fuses associated with a single panel. Go to **Subsystem > Subsystem Details > Downstream Loads**, and then select the **GO TO** button of the **Panel** that contains the breakers/fuses configuration you want to change. In the **Downstream Loads** table, select **Export to CSV**.

4. In the spreadsheet program, enter the breaker or fuse information as needed. Ensure that you do not to change the Owner or Identity column. This is required to import the configuration correctly. Save the file.
5. Select the **Import Configuration from CSV** button and select the edited file.
6. Once uploaded, verify the configuration is correct.

10.8. The subsystem layout

Distribution subsystems contain a **Layout** page to visualize the layout of the panels. This page shows the panels, including a graphical representation of whether the panels are linked (in Smart BDFB).

- In smart subsystems, panels are arranged two panels per row, to best match the LCD screens of the smart devices.
- In user defined subsystems, panels are arranged one per row to more closely represent a physical distribution system.

Selecting a panel will display the details on the right side of the layout page, as well as a table for breakers, and for shunts (user defined subsystem only). This is available via the web interface only.

To view the **Layout** page, go to **Systems > Distribution System > Subsystems**, then select the **GO TO** button of the subsystem required. Select to enter the **Layout** menu.

10.9. Map shunts to ADIO module inputs

The **Map Shunts to ADIO Inputs** wizard assists the process of mapping ADIO module shunt inputs to shunt inventory items. We recommend that your ADIO modules are named before launching this wizard to help identify which ADIO modules to select.

Using the wizard you can select to map in bulk or individually. In bulk mode, the current sources of the shunt inventory in the subsystem are set automatically to the shunt inputs of the ADIO modules selected in the wizard; the ADIO modules will be mapped in the order in which they were selected in the wizard. In individual mode, you can select an ADIO module shunt input for each shunt.

Within the distribution system, this wizard is only available for user defined subsystems. You can launch this wizard from any of the tables in subsystems that show shunts. The following example shows how to configure a subsystem for a Cordex® CXPS-C centralized power system.

To create a Cordex® CXPS-C centralized distribution subsystem:

1. Follow the steps detailed in the **Creating a User Defined Subsystem** section, creating six panels, with four breakers per panel, and one shunt per breaker.
2. Ensure that four Cordex® CXC HP 6i ADIO peripherals are acquired and named as per the schematic (#1-#4).
3. Go to **Systems > Distribution System > Subsystems > Subsystem > Shunts**, and select **Map Shunts to ADIO Inputs**.
4. On the **Shunt Mapping Type** step, ensure the mapping type is selected as **Map Shunts in Bulk** and select **Next**.
5. Leave the first panel selected in the **Select Starting Panel** step, and select **Next**.
6. On the **ADIO To Shunt Configuration** step, set the ADIO Configuration as **ADIOs Wired Sequentially** and select **Next**.
7. Select ADIO #1 from the dropdown list, and then select **Add Selected ADIO to List**. You will see the list below update with the ADIO module you just selected.
8. Repeat for ADIO modules #2 to #4, and then select **Next**.
9. The **Review** step details which inputs are mapped to which shunts. Review to ensure it matches the wiring schematic.
10. Select **Next**, and the 24 inputs of the four Cordex® CXC HP 6i-ADIO peripherals will now be mapped to the 24 shunts in the user defined subsystem.

11. DC source systems

This section provides a brief overview of the components and functions of a DC source system. In this system, DC sources external to the controller (PV cells or DC generators), can be created and monitored.

11.1. Create a DC source system

There is no DC source system on a new controller. Creating a DC source system is done via using the **Create System** wizard. There is no configuration required at the system level.

You can also import a DC source system via a configuration file.

The controller supports multiple DC source systems. It is recommended to use multiple DC source systems to separate different types of DC sources contributing to the DC bus. For example, a user can create a PV DC source system, and a generator DC source system. This is optional, and a users can group DC sources together however makes the most sense for their specific use case.

When first created, a DC source system is empty. DC sources must be added to give the system meaning. The system-wide voltage and current readings are **Unknown** when the system is first created. These values will be the average of all DC source voltages, and the sum of all DC source currents.

To create a DC source system:

1. Go to **Systems > Add or Remove Systems** and select the **Create System** button to launch the **Create System** wizard.
2. From the dropdown list, select **DC Source System**, then select **Done**.
3. A DC system is added to the **Inventory** table.
4. Go to **Systems > DC Source System > Status & Config** and enter a **Name**, **Description** and any other identifying information required.

The **Linked System** indicates which system will have the DC source in its power flow.

11.2. Create and configure a DC source

A **DC Source** will represent one single piece of inventory which is external to the controller, providing DC power to the bus. For example, a DC Source could be a PV array.

A special type of DC source is provided to model a DC generator. This DC source has additional capabilities for controlling a generator using a relay to start and stop it, based on a voltage or a set of optional conditions.

To create and configure a DC source:

1. Go to **Systems > DC Source System > DC Sources**.
2. In the **DC Sources** table, select one of three types of DC sources.

- A generic **DC Source**.
 - A **DC Generator** is a specialized type of DC Source which can automatically control the starting and stopping of a generator with the use of a relay, based on conditions specified.
 - A **Legacy DC Generator** can also automatically control the starting and stopping of a generator, but has been succeeded by the DC Generator option above.
3. After the DC source has been added, select the **GO TO** button.
 4. In the **Configuration** table, set the **Name** and **Description** to identify the **DC Source**.
 5. In the **Configuration** table, set the **Voltage Source** to the ADIO module voltage sensor reading that is monitoring the voltage of this DC source. Do the same for **Breaker/Fuse Source** (if applicable).
 6. In the **Configuration** table, set the **Current Source** to the configured **Shunt** that is monitoring the current of this DC Source.



Notice: A **Shunt** needs to be created and configured before the **Current Source** of this DC source can be configured.

11.3. DC source system effect on other systems

A DC source system is useful in representing external equipment for inventory purposes. Its strength lies in making DC system calculations more accurate. Many DC systems will use a battery shunt to read the battery current, and the load current will be calculated using = **(Total Rectifier O/P Current - Battery Current)**.

In situations where there are DC sources external to the controller, this calculation would not be sufficient.

When DC source systems are created, two new calculations are available:

- = **(Total Rectifier O/P Current - Battery Current + Total DC Source Current)**
- = **(Total Rectifier O/P Current - Total Load Current + Total DC Source Current)**

These can be used when a DC source is present to ensure the contributions of the DC sources to the system currents will be accurate. In the case that both load and battery use shunts to measure current, a Custom Data can be used to include the contributions from the DC sources.

In addition to the above, DC source systems will appear on the Power Flow in the relevant diagrams, giving a more complete picture of all the power sources flowing through the system.



Notice: At present, a DC source only appears on the Power Flow for a DC system and its battery and on the FXM HP UPS system and its battery.

12. AC source systems

This section provides a brief overview of the components and functions of an AC source system. AC source systems are intended to be used by customers who need to model multiple AC sources for their system. An example might be a system that has a set of rectifiers fed from AC mains, and a different set fed from a generator. For customers with a single AC source, or even multiple sources such as mains and generator which switch over automatically with a transfer switch, it is usually not necessary to model an AC source system.

12.1. Create an AC source system

There is no AC source system on a new controller. Creating an AC source system is done using the **Create System** wizard. There is no configuration required at the system level.

You can also import a AC source system via a configuration file.

The controller supports multiple AC source systems. Multiple AC sources can be modeled within the same AC source system. Users can group AC sources together to best suit their specific use case.

When first created, an AC source system is empty. AC sources must be added to give the system meaning. The system-wide voltage readings are **Unknown** when the system is first created. These values will be the average of all AC source voltages for each phase.

To create an AC source system:

1. Go to **Systems > Add or Remove Systems** and select the **Create System** button to launch the **Create System** wizard.
2. From the dropdown list, select **AC Source System**, then select **Done**.
3. An AC system is added to the **Inventory** table.
4. Go to **Systems > AC Source System > Status & Config** and enter a **Name**, **Description** and any other identifying information required.

12.2. Create an AC source

An **AC Source** will represent one AC input to the system, for example AC Mains.

To create and configure an AC source:

1. Go to **Systems > AC Source System > Inventory**.
2. In the **AC Sources** table, select **Add AC Source**. The **Add AC Source** wizard will launch.
3. Set the **Name** to identify the **AC Source**.
4. Select one of three types of AC sources.

- A **Simple AC Source** can be used to model an AC source with voltage readings for each phase. This source includes **AC Fail** and **Urgent AC Fail** alarms.
 - A **Generator** is a specialized type of AC source which can automatically control the starting and stopping of a generator with the use of a relay, based on conditions specified.
 - A **Legacy Generator** can also automatically control the starting and stopping of a generator, but has been succeeded by the Generator option.
5. Select the **Phase** for your **AC Source**.
 6. On the **Alarms** page, select whether the AC Input Fail alarm should be enabled for this source. Select **Yes** or **No**.
 7. On the **Voltage Readings** page, select the system from which the AC source will obtain its readings.
 8. If a DC system was chosen for the **Voltage Readings** source in step 7, there will be an option to launch the **Map Rectifiers to AC Source** wizard on the **Results** page.



Notice: If the **Voltage Reading Source System** has been set to a DC system, the phase voltage sources will be automatically set to the mapped rectifiers. If the **Voltage Reading Source System** has been set to an Inverter system, these phase voltage sources will be set to read from the Inverter system. If the Voltage Reading Source System is left unknown, these phase voltage sources should be set to read from transducers or any other voltage sources as desired.



Notice: If the **Voltage Reading Source System** has been set to a DC system, and the AC Fail alarms are enabled, the AC Input Fail alarm will be calculated in the same manner as the DC system's AC Fail alarm. If 90 percent of the rectifiers mapped to this AC source have failed, then the AC Input is assumed to be failed. Otherwise, if the **Voltage Reading Source System** is set to an Inverter system, or left unset, the AC Input Fail alarm will be activated if any one of the phase voltages falls below 10 V.

12.2.1. Map rectifiers to an AC source

An **AC Source** can get its data from either a DC system, an inverter system, or from transducers.

To map rectifiers from a DC system to an AC source:

1. Launch the **Map Rectifiers to AC Source** wizard. This can either be run directly from the results page of the **Add AC Source** wizard, or launched from **Systems > AC Source System > Inventory > AC Source** page.
2. Choose rectifiers to map from the **Selected** column. If rectifiers have previously been mapped to this source, they will show as selected. Select **Next**.
3. The **Review** step will show the changes requested. Selecting **Cancel** at this time will discard your changes. Select **Next** to accept your changes.

The chosen rectifiers will be mapped to this AC Source.

 **Notice:** The rectifier mapping can also be changed one-by-one for each rectifier, in the **Systems > DC System > Inventory > Rectifiers > Phase Mapping** table.

 **Notice:** The rectifiers can also be assigned to a particular phase. This can be done through the **System > DC System > Inventory > Rectifiers > Phase Mapping** table.

*Rectifiers that are left at the default setting of **No Phase** will be assumed to belong to Phase 1. If a rectifier has been set to a phase that does not exist, that rectifier's voltage values will not be included in the voltage calculations for the AC source.*

13. Cordex® CXPS-HSS Hyperboost converter system

This section provides a brief overview of the components and functions of a CXPS-HSS Hyperboost converter system.

13.1. Introduction to CXPS-HSS Hyperboost systems

A Cordex® CXPS-HSS Hyperboost converter system takes a DC input voltage 48V and converts it to a different output voltage 58V. A Hyperboost system provides flexibility that allows you to maintain a single voltage battery system. Converters provide DC-DC power conversion (for example, from -48 V to -58 V) to produce a consistent voltage source for equipment that is not compatible with the primary plant voltage. Converters can be used to create dual voltage capability in new systems **or** upgrades to existing DC plants. They provide tight voltage regulation for sensitive loads as well as galvanic isolation.

Components of a CXPS-HSS Hyperboost system

A Hyperboost system consists of a DC source, converters and a load as shown in the following diagram. Converters should have dedicated fuse or circuit breaker positions on the main DC power system for protection and isolation.

Figure 13-1 Example CXPS-HSS Hyperboost system

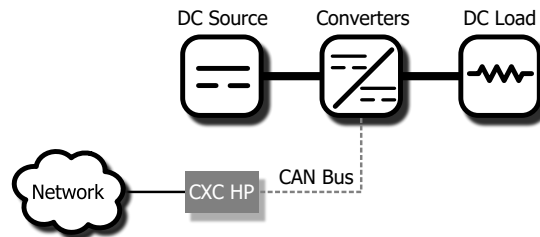

13.2. Creating a CXPS-HSS Hyperboost system

There is no Hyperboost system on a new controller. Creating a Hyperboost system is done using the **Create System** wizard. In the current release, more than one Hyperboost system are supported.

You can also import a configuration file containing a Hyperboost system from another controller.

A new power system can be created from the controller LCD or the web interface, via the **Systems > Add or Remove Systems** menu. Both have wizard assistance to help step you through the process to create the new system. You can create a 48V-58V system. When the system is created, an associated load is also created.

The Hyperboost system created will have a reasonable set of defaults and associated alarms. Optional converter items, such as Name, Description, System Number, and Serial Number, can be used to describe and organize your system.

Newly discovered converters are automatically assigned to the Hyperboost system. However if there is more than one Hyperboost system, converters are grouped into **Unassigned Modules**, and then you can add them to the system manually.

You can configure the converter alarms associated with the system. You can enable or disable the alarms, change the priority, map relays to the alarms, and where applicable, modify the thresholds.

To create a converter system:

1. Go to **Systems > Add or Remove Systems**.
2. Select **Create Converter System**. Name the system if required.
3. From the **Select System Type** dropdown list. Select **Hyperboost System 48V-58V**
4. Step through the rest of the wizard instructions.
5. Launch the **Configure Hyperboost System** wizard to configure the basic system settings and the system inventory.

13.3. Configure the CXPS-HSS Hyperboost converters

These settings include start delay, output voltage, or over-voltage protection threshold.



Notice: *The load bus output voltage is also the voltage that the converters default to if they lose communication with the controller. The converters will drop any of the adjustments made by the controller to perform load sharing and just try to meet the configured output voltage.*

This feature has a time delay that varies according to converters. Most converters revert to output mode after five minutes. Check the converter manual for a list of default parameters.

To configure the converters:

1. Go to **Systems > Hyperboost System > Inventory > Converters > Configuration**.
2. In the **Configuration** table, set up your converter group configuration settings. These include, **Load Bus Output Voltage** and **Load Bus Over-voltage Protection Limit** threshold.
3. Configure the settings for the converters. The values for these settings depend on your specific system.

13.4. Configure the shunts

By default the system has no shunts. You may add or remove shunts as needed.

To configure a shunt you need an ADIO module with current inputs. The shunt will map the current inputs from the ADIO module to the **Load Current Source** field of the **Load** configuration table or the **Battery Current Source** field of the **Battery Configuration** table.

To configure the shunts:

1. Go to **Systems > Converter System > Inventory > Shunts**. You will see a list of shunts in the system. Add or remove shunts from this page.
2. Select the **GO TO** button for the shunt you want to configure.
3. In the **Configuration** table, assign the shunt a name and description. We recommend that you assign the shunt a name that represents the actual shunt. For example you might name it **Battery Shunt**.
4. Select the **Shunt Current Source**.

This is the current input on an ADIO module that takes a voltage reading across the shunt.

5. Enter the **Range in Amps** for the shunt.
6. Enter the **Range in Millivolts** for the shunt.
7. Enter the **Offset Calibration** for the shunt if the shunt reading error is too low or high.

13.5. Configure the loads

By default the system has one load. You may add or remove loads as needed.

To configure the loads:

1. Go to **Systems > Converter System > Inventory > Loads**. You will see a list of loads in the system. Add or remove loads from this screen.
2. Select the **GO TO** button for the load you want to configure.
3. In the **Configuration** table, assign the load a name and a description. We recommend that you assign the load a name that represents the actual load.
4. Select the **Load Voltage Source**. This is the voltage input on an ADIO module that takes a voltage reading near the load.

If you do not have a sensor connected, you may want to select the **Average Converter Output Voltage**.

5. Select the **Load Current Source**. This is the shunt input that reads the load current. If you have a real shunt reading for the load current, then select the shunt from the dropdown list. If you don't see the shunt you want, then create it.

If you do not have a shunt for reading the load current, you may want to select the **Total Output Current** for the converter system.

6. Select the **EDIT** button for the **Load Breaker/Fuse Source**. Select the digital input on the ADIO module which is connected to monitor the breaker or the fuse.

If you need to change the polarity for the **Load Breaker/Fuse Open** alarm, go to the **Modules** page, from the **All Modules** table, select the ADIO module required, and then select the **GO TO** button to access the **Digital Inputs** table.

7. Configure the load alarms.

13.6. Configure the current transducer

The system, by default does not contain any current transducers. You can add or remove current transducers as needed. To configure a current transducer you need a voltage input on an ADIO module.

To configure a current transducer:

1. Go to the system where you want to add the transducer and navigate to the inventory page. Go to **Systems > Inventory > Other Transducers > Current Transducer**. There will be a list of current transducers in the system. Add or remove them from this page.
2. Select the **GO TO** button for the **Current Transducer** you want to configure.
3. In the **Configuration** table assign the **Current Transducer** a name and a description.
4. Select the **CT Current Source**. This can be any voltage source.
5. Enter the **Range in Amps**.
6. Enter the **Range in Volts**.
7. Optional: enter the **Offset** calibration for the **Current Transducer** if the reading error is too low or high.

13.7. Configure the general purpose transducer

The system, by default does not contain any general purpose transducers. You can add or remove general purpose transducers as needed. To configure a general purpose transducer you need a voltage input on an ADIO module.

To configure a general purpose transducer:

1. Go to the system where you want to add the transducer and navigate to the inventory page. Go to, **Systems > Inventory > Other Transducers > General Purpose Transducer**. There will be a list of general purpose transducers in the system. Add or remove them from this page.
2. Select the **GO TO** button for the **General Purpose Transducer** you want to configure.
3. In the **Configuration** table assign a name and a description.
4. Select the **Transducer Input Source**. This can be any voltage source or a custom data.
5. Enter the **Transducer Input Minimum in Volts** and **Transducer Input Maximum in Volts**.
6. Enter the **Transducer Output Minimum** and **Transducer Output Maximum**.
7. Select the **Units and Precision**
8. Optional: Enter the **Offset** calibration for the calculated **Value** if the reading error is too low or high.

The **Calculated Slope** and the **Offset** are used to convert the **Input Source Value** to the **Value**. The value is displayed in the selected units and precision.

13.8. Matrix C16™ high density connectorized DC distribution breaker panel

This section provides a brief overview of the components and functions of Matrix C16™ high density connectorized DC distribution breaker panel.

13.8.1. Introduction to Matrix C16™ high density connectorized DC distribution breaker panel

The Matrix C16™ high density connectorized DC distribution breaker panel provides high reliability, high power, DC distribution in a compact 1RU space to maximize rack space for signal equipment.

Traditional telecom breaker and fuse panels use terminal lugs for output connections and therefore require specialized technicians to add or change loads. The Matrix C16 panel uses locking plug-in connectors offering a significant improvement in ease of use and cost of installation. The 1RU configuration, with 400A of current capacity and 16 breaker positions, offers industry leading density. Accepting single-pole breakers rated up to 100A each, the Matrix C16 panel can support the majority of network loads within headends, COs, and hub sites. The internal buswork has been enlarged, adding 33 percent more total ampacity than our standard Matrix 300 panel.

13.8.2. Matrix C16™ high density connectorized DC distribution breaker panel in a CXPS-HSS Hyperboost system

On the controller, when connected via CAN bus and acquired, the Matrix C16™ high density connectorized DC distribution breaker panel (device) is seen as a module (Model: Matrix C16). If acquired appropriately, a user can go to the **Modules** page of the user interface to view that module within the **CAN Modules** table. Use the **GO TO** button to see the information presented by the module.

Although Matrix C16 module data can be observed through the **Modules** page of the user interface, it can also be assigned to a Hyperboost system. The benefits of assigning a module to a Hyperboost system: 1) data from all assigned Matrix C16 modules will be aggregated, 2) alarming capabilities are available, 3) and data from the modules will be presented on the Hyperboost system power flow diagram. Modules are auto-assigned by default but assignment to another Hyperboost system can be done if desired.

To assign Matrix C16 modules to a system:

1. Go to **Systems > Hyperboost System > Inventory > Matrix C16 Modules**
2. Any modules available for assignment will appear in the **Unassigned Modules** table.

After modules are assigned, aggregated data can be viewed in the **Distribution Summary** table found at **Systems > Converter System > Status**.

14. Generator

This section provides an overview of the components and functions of the controller's support for AC and DC generators.

A generator is a specialized type of AC or DC source which can automatically control the starting and stopping of a generator with the use of a relay, based on start and stop conditions specified.

By customizing the start and stop conditions, the user can adjust the generator control for their specific situation. For example, start and stop conditions can be added which run the generator based on a schedule in order to exercise the generator.

The generator has a built in and configurable **Minimum Runtime** to protect the generator from short startups. If a stop condition causes the **Call to Stop** to be true, the control system will first wait for the generator to run for the minimum runtime before it commands the generator to stop.

The generator ensures stable operation with its configurable **Equation Stability Delay**. For example, while a start condition may become true, the **Call to Start** will evaluate all the enabled start conditions for the length of the **Equation Stability Delay** before it becomes true. This means that if a change in the dependent start or stop conditions is not stable for the configured time, it will not affect the generator control. This effectively filters out sensor noise and further protects the generator from frequent and short startup cycles.

Several statistics are available to give insight into the historical behavior of the generator. By default, the **Startups in Time Period** keeps track of the number of startups in the last 24 hours. The **Total Startups** and **Total Runtime** are also recorded.

In the event of hardware malfunction or misconfigurations, several alarms are supplied with the generator to alert the user in a variety of adverse situations, such as the **Startup Frequency High** alarm, which activates when the **Startups in Time Period** exceeds a given threshold.

14.1. Create an AC generator

To create an AC generator:

1. If an AC source system does not already exist, create it at **Systems > Add or Remove Systems** and launch the **Create System** wizard. Select the **AC Source System** from the dropdown list and finish the wizard.
2. Go to **Systems > AC Source System > Inventory**.
3. In the **AC Sources** table, select **Add AC Source**. The **Add AC Source** wizard will launch.
4. Set the **Name** and then select **Next**.
5. Select **Generator** from the **AC Source Type** dropdown list. Select **Next**.
6. Select the **Phase** for your **AC Source**. Select **Next**.
7. On the **Alarms** page, select whether the AC Input Fail alarm should be enabled for this source. Select **Yes** or **No**.

8. On the **Voltage Readings** page, select the system from where the AC source will obtain its readings.
9. Review your settings and select **Next**.
10. In the **Results** step, there will be an option to launch the **Configure Off-Grid Settings** wizard. Alternatively, this wizard can be found in the **Status & Config** page inside the **Configuration** table of the new AC generator.
11. After the AC generator has been added, select the **GO TO** button. From here, the generator can be configured.

14.2. Create a DC generator

To create a DC generator:

1. If a DC source system does not already exist, create it at **Systems > Add or Remove Systems** and launch the **Create System** wizard. Select the DC source system from the dropdown list and finish the wizard.
2. Go to **System > DC Source System > DC Sources**.
3. In the **DC Sources** table, select **Add DC Generator**.
4. After the DC generator has been added, select the **GO TO** button. From here, the generator can be configured.

14.3. Configure the generator

1. Configure the **Generator Control Relay**. Inside the **Generator Control** page and in the **Generator Control** table, select the **EDIT** button of the **Generator Control Relay** to choose the relay that will control the starting and stopping of the generator. This relay can also be driven by other features like alarms. This provides maximum flexibility in generator control, but requires extra caution to ensure this generator relay is shared only when intended.
2. Configure the **External Status Signal Source**. Inside the **Status & Config** page and in the **Configuration** table, select the **EDIT** button of the **External Status Signal Source** to choose the digital input which signifies whether or not the generator is running.



Notice: *Configuring the **Generator Status Signal Source** is optional. If it is configured, it will be used for the **Generator Status Mismatch** alarm. If the **Generator Status Signal Source** is not configured, the **Generator Status Mismatch** alarm will never activate.*

3. See [Start and stop conditions \(on page 147\)](#) to create specific conditions where the generator should startup and shutdown.
4. See [Start and stop logic \(on page 149\)](#) to understand how the start and stop conditions are used to calculate the **Call to Start** and **Call to Stop**.
5. See [Generator state \(on page 151\)](#) to understand how the generator control processes the **Call to Start**, **Call to Stop**, and **Manual Generator Start** and **Manual Generator Stop** button

pushes. This section also describes what to do if the generator state shows suspended because of a configuration error.

6. See [Alarms \(on page 152\)](#) to configure the alarms in the event of an adversely functioning system.
7. Once fully configured, enable the **Generator Control**. Inside the **Generator Control** page and in the **Generator Control** table, select the **EDIT** button of **Generator Control** to enable the automatic generator on/off control to command the **Generator Control Relay**

14.4. Start and stop conditions

The automatic on/off control of the generator is based on start conditions and stop conditions. By customizing the start and stop conditions, the user can adjust the generator control for their specific situation. For example, start and stop conditions can be added which run the generator based on a schedule in order to exercise the generator.

The start and stop conditions add great versatility to the generator control; however, care must be taken to ensure the user's customization behaves as anticipated. For example, if the generator has run past the configured **Minimum Runtime** and the **Call to Stop** becomes true, it will shutdown. But if the **Call to Start** is also true, the generator will immediately startup again.

14.4.1. Default start and stop conditions

When a generator is created on a power system with a DC system and battery, the generator will be setup by default to startup on low DC system voltage, and stop when the battery returns to float mode.

Table 14-1 Default start and stop conditions when a DC system and battery are present

	Condition name	Value to test
Default Start Condition	StartOnLowVoltage	DC System: System Voltage
Default Stop Condition	StopWhenBatteryCharged	Battery: Battery Mode

If there is no battery, the generator will be setup by default to startup on low DC System voltage, and stop when the it approaches to System Float Voltage.

Table 14-2 Default start and stop conditions when a DC system is present without a battery

	Condition name	Value to test
Default Start Condition	StartOnLowVoltage	DC System: System Voltage
Default Stop Condition	StopOnFloatVoltage	DC System: System Voltage

If there is no DC system, then no default start or stop conditions will be created. To add custom start and stop conditions, see [Add start and stop conditions \(on page 147\)](#).

14.4.2. Add start and stop conditions

The user can add an unlimited number of start or stop conditions, and can remove the default start and stop conditions if desired.

1. From within the **Generator Control** page, select the **Add Start Condition** or **Add Stop Condition** button.
2. The wizard will guide you through all the steps required to add a start or stop condition. After completing the wizard, no further configuration is needed for that start or stop condition.

 **Notice:** Start conditions and stop conditions must be given a name. This name cannot have spaces or special characters, as it is used to automatically write the **Start Equation** or **Stop Equation**. If it is misnamed, an error will be presented in **Call To Start** or **Call To Stop**, and the **Generator State** will show suspended. See [Generator state \(on page 151\)](#) for more details.

 **Notice:** The **Limit** is not configured in the **Add Start Condition** or **Add Stop Condition** wizard if it is not needed. The **Limit** is only used for less than or greater than comparisons, and otherwise can be left blank.

 **Notice:** If the **Value to Test** needs to be changed to a different entry, a new start or stop condition should be made, and the old removed.

14.4.3. Adding complex start and stop conditions

For some complex situations, the start and stop conditions may not provide enough flexibility to control the generator start and stop as desired. In this case, the complex logic can be created using custom data, and then a start condition or stop condition can select that custom data as the **Value to Test**. See the Custom Data section for more details.

14.4.4. Testing start and stop conditions

To simplify testing the control logic and ensure expected generator operation, each start and stop condition has a **Test** button.

If the test is active, the **Test Time Remaining** will show the time until the test stops. When the test is active, the start or stop condition's **Value** will be true regardless of the **Value To Test**. The test will run 60 seconds longer for each time **Extend Test** is selected, or until it is manually stopped. This test can be useful to ensure the generator start and stop logic is working as expected. If **Generator Control** is **Enabled**, the test can cause the generator to startup or shutdown.

14.4.5. Example: Start and stop the generator on a schedule

Scheduled startups and shutdowns can be useful in order to exercise a diesel or gas generator. Sometimes more complex logic is needed for generator control, and starting and stopping based on a schedule is an example of this.

1. Go to **Controller > Programmability > Custom Data**.
2. Select the **Add Delay Timer** button in the **Timers** table.
3. Select the **GO TO** button in the new line item to edit the configuration.
4. Set the **Name** of the timer to **Exercise Generator**.
5. Set the **Delay** for the amount of time the generator should run for when it is exercised.
6. No other entries need to be configured in the delay timer.
7. Go to **Controller > Programmability > Scheduler**.
8. Select the **Create Scheduled Action** button to launch the wizard to create the scheduled times when the generator should startup. Follow the wizard through to the Action page. On the **Action** page, select the **Exercise Generator (Delay Timer): Force Timer to Start** option.
9. Review and complete the wizard. Now, whenever the scheduled action runs, the **Exercise Generator** timer will begin counting down, and the **Output** will be **True** during this time.
10. Return to the **Generator Control** page, and launch the **Add Start Condition** wizard.
11. Name the start condition **ExerciseGeneratorStart** with no spaces, and select **Next**.
12. From the **Value to Test** dropdown menu, find the **Exercise Generator** delay timer in the list, and select the **Output**. Select **Next**.
13. From the **True If** dropdown menu, select **True** to indicate that the start condition should be true when the Exercise Generator **Output** is **True**.
14. Review and complete the wizard.
15. Next, launch the **Add Stop Condition** wizard.
16. Name the stop condition **ExerciseGeneratorStop** with no spaces, and select Next.
17. From the **Value to Test** dropdown menu, again, find the Exercise Generator delay timer in the list, and select the **Output**. Select **Next**.
18. From the **True If** dropdown menu, this time select **False** to indicate that the stop condition should be true when the Exercise Generator **Output** is **False**.
19. Review and complete the wizard.



Notice: *The generator control now has a start condition and a stop condition that will become true or false according to the schedule you created. To ensure correct generator on/off control, ensure that other start and stop conditions do not interfere with this schedule by using the test buttons on the start and stop conditions.*

14.5. Start and stop logic

In addition to the automatic on/off control, the generator can be started and stopped manually with the **Manual Generator Start** and **Manual Generator Stop** buttons. The generator cannot be manually started or stopped when the **Generator State** shows disabled or suspended. See [Generator state \(on page 151\)](#) for more details.

The **Equation Stability Delay** sets the time that the **Start or Stop Equations** must hold their new value before the **Call to Start** or **Call to Stop** changes.

14.5.1. Start logic

The **Start Logic** choice decides whether just one, or all start conditions must be true for the **Call to Start** to become true. This decides how the start conditions will be assembled into a logical equation.

The **Start Equation** is an automatically written equation of all the enabled start conditions. If there is more than one start condition, the equation will be assembled with '&' or '|' symbols according to the **Start Logic**. If all start conditions must be true for the **Start Equation** to evaluate to true, then the equation will be written as "MyStartCondition1 & MyStartCondition2". If just one start condition must be true for the **Start Equation** to evaluate to true, then the equation will be written as "MyStartCondition1 | MyStartCondition2".

The **Call to Start** is based on the logical result of the **Start Equation**, as true or false. For example, if a start condition causes the **Start Equation** to change from false to true, then the **Call to Start** will begin counting down for the configured duration of the **Equation Stability Delay**. If the **Start Equation** continues to evaluate as true through the whole stability delay, then the **Call to Start** will become **True**. Otherwise, if the **Start Equation** evaluates as false at any point during the stability delay, the count down will stop, and the **Call to Start** will remain **False**.



Notice: *The **Call to Start** will always be evaluating the start conditions, even when the **Generator Control** is **Disabled**, so that the user can test the logic without starting the generator. Furthermore, the **Call to Start** will be evaluated even while the generator is running. If the **Call to Start** is **True** when the generator shuts down, the generator will immediately startup again. Therefore, care should be taken when defining start and stop conditions so that they do not interfere with each other.*

14.5.2. Stop logic

The **Stop Logic** choice decides whether just one, or all stop conditions must be true for the **Call to Stop** to become true. This decides how the stop conditions will be assembled into a logical equation.

The **Stop Equation** is an automatically written equation of all the enabled stop conditions. If there is more than one stop condition, the equation will be assembled with '&' or '|' symbols according to the **Stop Logic**. If all stop conditions must be true for the **Stop Equation** to evaluate to true, then the equation will be written as "MyStopCondition1 & MyStopCondition2". If just one stop condition must be true for the **Stop Equation** to evaluate to true, then the equation will be written as "MyStopCondition1 | MyStopCondition2".

The **Call to Stop** is based on the logical result of the **Stop Equation**, as true or false. For example, if a stop condition causes the **Stop Equation** to change from false to true, then the **Call to Stop** will begin counting down for the configured duration of the **Equation Stability Delay**. If the **Stop Equation** continues to evaluate as true through the whole stability delay, then the **Call to Stop** will become **True**. Otherwise, if the **Stop Equation** evaluates as false at any point during the stability delay, the count down will stop, and the **Call to Stop** will remain **False**.

Notice: The **Call to Stop** will always be evaluating the stop conditions, even when the **Generator Control is Disabled**, so that the user can test the logic without starting the generator. Furthermore, the **Call to Stop** will be evaluated even while the generator is stopped. If the **Call to Start is True** when the generator shuts down, the generator will immediately startup again. Therefore, care should be taken when defining start and stop conditions so that they do not interfere with each other.

14.6. Generator state

The **Generator State** describes whether the generator is running or not, and what action the generator control is doing before moving to the next state. Except if the generator is disabled, suspended, or manually started or stopped, the actions follow this order:

1. Stopped and waiting for **Call to Start** to be true.
2. Start is requested. Activating control relay.
3. Running and waiting for generator to run for minimum runtime.
4. Running and waiting for **Call to Stop** to be true.
5. Stop is requested. De-activating control relay.

Figure 14-1 Generator state flowchart

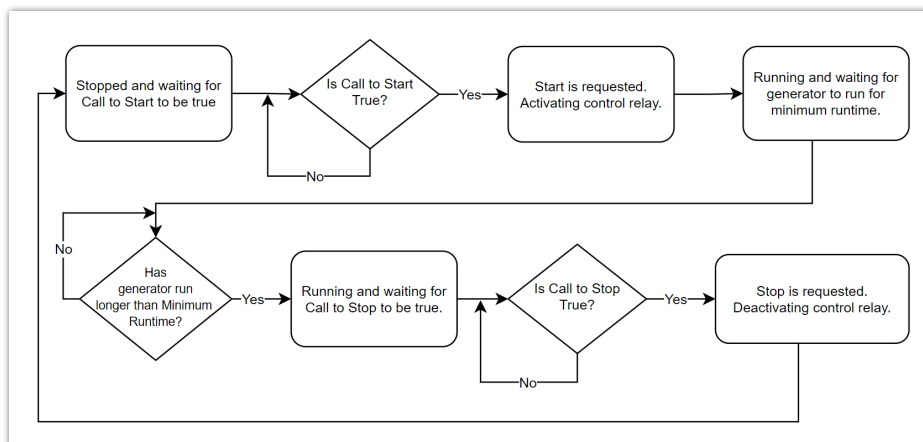

Notice: The **Manual Generator Start** button can be pressed When the **Generator State is Stopped and waiting for Call to Start to be true**. The generator cannot be manually started when the **Generator State** shows disabled or suspended.



Notice: The **Manual Generator Stop** button can be pressed When the **Generator State** is **Running and waiting for generator to run for minimum runtime** or **Running and waiting for Call to Stop to be true**. The generator is already stopped when the **Generator State** shows **disabled or suspended**.

The **Generator State** shows **Disabled** if the **Generator Control** is set to **Disabled**. The mapped **Generator Control Relay** will not be energized in this state.

The **Generator State** can also show suspended due to a configuration error. The following are all possible suspended states along with recommendations to get out of the suspended state:

- **Suspended - No Relay Mapped:** Select a relay which controls the generator in the **Generator Control Relay** entry.
- **Suspended - No Start Conditions:** Either there are no start conditions, or all the start conditions are disabled. Add a start condition, or enable a start condition that is already present to leave this suspended state.
- **Suspended - No Stop Conditions:** Either there are no stop conditions, or all the stop conditions are disabled. Add a stop condition, or enable a stop condition that is already present to leave this suspended state.
- **Suspended - Start Equation Error:** Given the enabled start conditions, The **Start Equation** could not be evaluated. The **Call to Start** has further details regarding the reason for this error. If the **Call to Start** shows "Error: Unrecognized Symbol" or "Error: Equation did not Parse" then a start condition needs to be renamed. The name cannot contain spaces or special symbols (except an underscore). If the **Call to Start** shows "Error: Variable Not Mapped", it means that the **Value to Test** of one of the start conditions was removed from the controller. The user should remove that start condition and add it again after ensuring the **Value to Test** exists on the controller once again.
- **Suspended - Stop Equation Error:** Given the enabled stop conditions, The **Stop Equation** could not be evaluated. The **Call to Stop** has further details regarding the reason for this error. If the **Call to Stop** shows "Error: Unrecognized Symbol" or "Error: Equation did not Parse" then a stop condition needs to be renamed. The name cannot contain spaces or special symbols (except an underscore). If the **Call to Stop** shows "Error: Variable Not Mapped", it means that the **Value to Test** of one of the stop conditions was removed from the controller. The user should remove that stop condition and add it again after ensuring the **Value to Test** exists on the controller once again.

14.7. Alarms

The generator alarms are available in the **Status & Config** page. The following alarms are available to alert the user of adverse situations:

- **Generator Startup Frequency High:** This alarm will activate when the **Startups in Time Period** exceeds its configured threshold during the given **Statistics Time Period**. This alarm could activate from a wide variety of adverse situations, such as low battery health, where the battery charge cycle becomes shorter as its health degrades.

- **Generator Running too Long:** If this alarm is active, then the generator has run longer than the threshold configured in the alarm's details page. The generator is still running because either the generator's **Call to Stop** is not **True**, or it has not exceeded its configured **Minimum Runtime**.
- **Generator Status Mismatch:** The **Generator Status Signal** is detecting that the status of the generator does not match what is expected. Either the generator is running when the **Generator Status** indicates it should not be, or else it is not running when it should be. This alarm does not activate until approximately 30 seconds after the mismatch is first measured, to allow time for the generator to startup or shutdown.

14.8. Legacy generator

A **Legacy Generator** is a specialized type of AC source or DC source which allows a generator to be started and stopped with a relay. The legacy generator has been succeeded by the generator, as described in the previous section.

The standard condition on which to start or stop a generator is based on a voltage. The controller allows the user to choose any voltage in the system and set it as the **Voltage to Monitor**, with a start threshold and a stop threshold. The generator will be started if the **Voltage to Monitor** falls below the **Start Voltage Threshold**, and will be stopped if the **Voltage to Monitor** climbs above the **Stop Voltage Threshold**.

The optional start or stop conditions can be used to start and stop the generator based on other types of conditions. For example, the battery SOC could be used. The ability to use Custom Data or other system values gives the generator control a lot of flexibility; however, care must be taken to ensure that the start and stop conditions make sense. Otherwise, it is possible for the user to create, for example, a start condition that is always true, in which case the generator would not stop running.

The Minimum Runtime assures that the generator will not be started to only run for too short a period of time. Once the generator has started, it will continue to run for the Minimum Runtime even if a stop condition has become true.

The Maximum Runtime is intended to ensure that the generator does not continue to run indefinitely even if no stop condition comes true. After running for the Maximum Runtime, the generator will attempt to shut down. It should be noted that if a start condition is still true, it would start up again immediately. In that case, an event message will be logged. Additionally, there is a **Generator Running Too Long** alarm that may be enabled to help alert the user to this situation.

14.8.1. Create a legacy AC generator

To create a legacy AC generator:

1. If an AC source system does not already exist, create it by going to **Systems > Add or Remove Systems** and launch the **Create System** wizard.
2. Go to **Systems > AC Source System > Inventory**.
3. In the **AC Sources** table, select **Add AC Source** button to launch the wizard.
4. Set the **Name** and then select **Next**.
5. Select **Legacy Generator** from the **AC Source Type** dropdown list. Select **Next**.

6. Select the **Phase** for your **AC Source**. Select **Next**.
7. In the **Alarms** page, select whether the AC Input Fail alarm should be enabled for this source. Select **Yes** or **No**.
8. In the **Voltage Readings** page, select the system from where the AC source will obtain its readings.
9. Review your settings and select **Next**.
10. In the **Results** step, there will be an option to launch the **Configure Generator Control** wizard. Alternatively, this wizard can be launched from the **Generator Control** table within the details of the new legacy AC generator source.

14.8.2. Create a legacy DC generator

To create a legacy DC generator:

1. If a DC source system does not already exist, create it at **Systems > Add or Remove Systems** and launch the **Create System** wizard
2. Go to **Systems > DC Source System > DC Sources**.
3. In the **DC Sources** table, select **Add Legacy DC Generator**.
4. After the legacy DC generator has been added, select the **GO TO** button. From here, the generator control and alarms can be configured.

14.8.3. Configure legacy generator control

From inside the legacy generator:

1. In the **Generator Control** table, select the **Configure Generator Control** button to launch the configuration wizard.
2. In the **Generator Control** dropdown menu choose from the following:
 - **Enabled:** Chose enabled if the generator can be controlled by a relay.
 - **Disabled:** If disabled is chosen no further configuration is required.
3. Under **Generator Control Signals** select the **Generator Control Relay** and the **Generator Status Signal Source**. Select **Next**.



Notice: The **Generator Control Relay** is mandatory as it is the relay that will be used to start and stop the generator. This relay can also be driven by other features like alarms. This provides maximum flexibility in generator control, but requires extra caution to ensure this generator relay is shared only when intended.



Notice: The **Generator Status Signal Source** is optional, but it should be mapped to a digital input which can be used to monitor whether or not the generator is running.

4. Under **Voltage to Monitor**, choose a voltage signal to be monitored.

- a. Enter a **Start Voltage Threshold**.
 - b. Enter a **Stop Voltage Threshold**.
 - c. Select **Next**.
5. Review your settings and select **Next**.

The generator has now been configured.

If the user wishes to use the optional start and stop conditions to start and stop the generator, these may be configured in the **Optional Start/Stop Conditions** table.

14.8.4. Configure legacy generator alarms

Additionally, the alarms for **Generator Control** may be configured. The **Generator Status Mismatch** alarm will be active if there is a **Generator Status Signal Source** configured, and the status does not match what is expected. For example, if the **Generator Command Status** indicates that the generator should be running, but the **Generator Status Signal Source** indicates that it is not (as reported in the **Generator Running** status field), the **Generator Status Mismatch** alarm will become active. Similarly, if the **Generator Command Status** indicates that the generator should not be running, but the signal indicates that it is, the alarm will activate. The **Generator Running Too Long** alarm is disabled by default. If enabled, it will indicate if the generator has run past the **Maximum Runtime** due to a start condition that is still true.

15. FXM HP UPS systems

For the components and functions of an FXM HP UPS system, please see **Alpha FXM HP 650, 1100, 2000 UPS Product Manual, User Guide ID: 0170022-J0**.

16. Thermal systems

This section provides a brief overview of the components and functions of a thermal system.

16.1. Introduction

A thermal system provides insight into a thermally controlled outdoor cabinet. It is intended to be used together with one or more FlexAir® thermal controllers. A thermal system enables activities such as logging system temperature measurements or monitoring fan speed, and holds various alarms related to an outdoor cabinet, such as unsuitable internal temperature alarms or fan failure alarms, if the thermal controller has fans.

16.2. Create a thermal system

To create a new thermal system:

1. Go to **Systems > Add or Remove Systems** and select the **Create System** button to launch the **Create System** wizard.
2. In the **Create System** wizard, in the dropdown list for the **Select System To Create Step**, choose to create a **Thermal System**.

16.3. Thermal system configurations

The thermal system is designed with the expectation of a 1:1 relationship with a physical cabinet. If the controller handles hardware in more than one cabinet, multiple thermal systems should be created. There may be situations where there is more than one thermal controller in a given cabinet. This is acceptable.

16.3.1. Single-cabinet setup

When the controller handles equipment in only one cabinet, a single thermal system should be created. When a thermal controller module is connected via CAN to the controller, by default, it is automatically added to the thermal system. If it has been setup for manual configuration, then add the modules to the thermal system manually as described in the multi-cabinet setup.

16.3.2. Multi-cabinet setup

When the controller handles equipment in multiple cabinets, a thermal system should be created for each physical cabinet. When there are multiple thermal systems, it is important to give each thermal system a custom name to differentiate them from each other. The controller does not know however, which cabinet the thermal controller modules are installed in. Therefore the modules must be manually added to the respective thermal systems. To do this:

1. From the **System** menu, Go into one of the previously created and named thermal systems and select the **Thermal Controllers** page.
2. Inside the **Modules Available for Assignment** table, all the available thermal controller modules should appear.
3. Select **Locate** on a thermal controller to activate blinking LEDs on the respective hardware. Repeat this procedure until you are able to identify which cabinet each module resides in. Once it is clear, select **Assign** on the modules which belong to the thermal system you are viewing.
4. Repeat this process for each thermal system until all thermal controllers are assigned to a system.

16.4. Logging temperatures

The thermal system obtains cabinet temperature data from the thermal controllers inside the cabinet. Once the thermal system has access to the temperature data, it is automatically logged in the controller's performance logs.

The thermal system has a placeholder for an Internal System Temperature, an External System Temperature, and three additional generic System Temperatures, in the case that more than two measurements are desired to be logged. Each of these system temperatures can be custom named to suite specific needs.

To configure the thermal system's cabinet temperature data:

1. Go to **System > Thermal System > Status & Config** page.
2. In the **System Temperatures** table, select the **GO TO** button on one of the system temperatures.
3. In the table for that System Temperature, configure the **Name** as desired.
4. Select the other **EDIT** button to choose a temperature probe from a thermal controller inside the thermal system. For more advanced settings (such as obtaining the average value of two temperature probes), a **Custom Data** can also be selected. Please see the user manual section regarding **Custom Data** for more information.
5. To view the logged data (available in both live charts and exportable CSV format), go to **Logs > Performance** and select the respective **System Temperature** from the **Performance Logs** table.

16.5. Logging filter replacement date

The filter replacement date can be logged to keep track of the cabinet's filter usage. Note that recording the replacement date does not activate any sort of time-based replacement indicator or replacement schedule, it is simply an optional tool to keep track of the date it was replaced.

1. Go to **Systems > Thermal System > Status & Config**.
2. In the **Status** table, select the **Log Filter Replacement** button. This will automatically set the date to today's date, and will additionally create a record in the **Events & Alerts** page. Note that this

button is not available when browsing through the controller's LCD. It is only available through the web interface.

3. This entry can also be manually set by selecting the **EDIT** button to allow customization of the value. When manually set, there is no record created in the **Events & Alerts** page.

16.6. Logging fan replacement dates

The fan replacement dates can be logged to keep track of the fan usage. Note that recording the replacement date does not activate any sort of time-based replacement indicator or replacement schedule, it is simply an optional tool to keep track of the date it was replaced.

1. Go to **Systems > Thermal System > Thermal Controllers** and select the respective thermal controller.
2. Inside the Fans table, select the **GO TO** button to view the table for a single fan. Once viewing a single fan's table, select the **Log Fan Replacement** button at the top of the table. This will automatically set the date to today's date, and will additionally create a record in the **Events & Alerts** page.
3. This entry can also be manually set by selecting the **EDIT** button to allow customization of the value. When manually set, there is no record created in the **Events & Alerts** page.

16.7. Alarms and alerts

This section provides a brief overview alarms and alerts for a thermal system.

16.7.1. Thermal controller module alert to thermal system alarm propagation

The thermal system's alarms table is located inside the **Status & Config** page. The alarms in this table are generated from aggregated data from the alerts table from each of the thermal controllers in the thermal system. For example, if a thermal controller activates its **Internal Temperature High** alert, then the thermal system that it belongs to will activate its **Internal Temperature High** alarm. Likewise, if one or multiple fans fail on a thermal controller inside the thermal system, then the thermal system's **Fan Fail** alarm will activate.

The exception to this propagation rule is the **Thermal Controller Comms Lost** alarm, which activates in the event that any thermal controller in that system loses communication with the controller.



Notice: A thermal controller must be assigned to a thermal system for its alerts to be counted in the the **CAN Modules** table of the **Modules** page. Otherwise its alerts will show as unknown.

16.7.2. Identifying the origin of an active alarm

In the event that a thermal system's alarm is active, select the active alarm graphic, or go to **Alarms > Active Alarms**. There is an **Active Alarms** table, as well as an Active Module Alerts table displayed. For most thermal system alarms, the respective module alert will appear in the Active Module Alerts table.

This will help identify which thermal controller is responsible for activating the system alarm. If the alarm was a **Fan Fail** alarm, the alert will also identify which fan on the thermal controller has failed.

16.7.3. Alarms where hardware does not exist

There is no concern if alarms exist in the software for hardware that does not exist. For example, if a cabinet is not configured with a filter, the **Filter Replacement Required** alarm will never activate.

17. Controller redundancy

For information on the controller redundancy function, please see the **Controller Redundancy Integration Guide (0350142-J0)**.

18. Power flow

This section provides an overview of the **Power Flow** feature.

18.1. Introduction to power flow

Power Flow is only available via the web interface of the controller. From the main dashboard, it displays live information about the power system and its inventory items, as well the relationships and the flow of power between them.

Power Flow is intended to be a single point for monitoring and troubleshooting the system. Key information and alarms are shown and you can use power flow to quickly drill down and investigate any alarms. A **Power Flow** for a **DC System** as shown in the following figure.

Figure 18-1 Power flow for a DC system

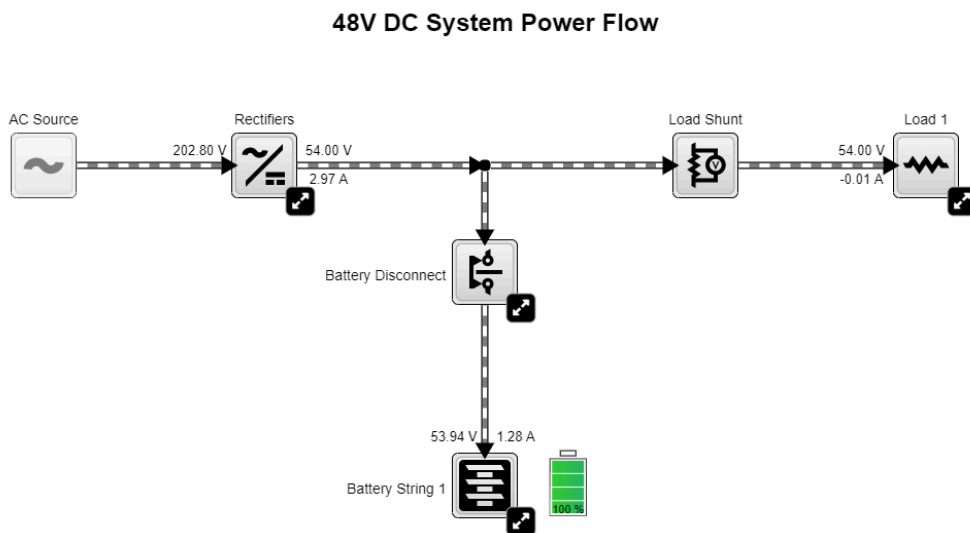

18.2. Access power flow

Power flow can be accessed through the menu bar in the web interface. If a system that is supported by power flow has been created, the **Power Flow** for that system will automatically appear in the menu when the **Power Flow** menu item is selected.

 **Notice:** Version 6.20 and later, power flow supports **DC**, **AMPS HP2**, **Distribution**, and **Line Power Systems**. If your site has one or more of these systems, go to **Systems > Add or Remove Systems** to create them.

18.2.1. Getting help

Help for the power flow feature can be accessed from any **Power Flow** by selecting the **Help** icon.

18.2.2. Use power flow configuration suggestions

Power flow can detect a missing configuration from the system’s inventory. In such instances, a special node will appear to allow quick configuration of the system. Selecting the node will bring up a dialog to set the missing configuration.

Figure 18-2 Power flow configuration suggestions

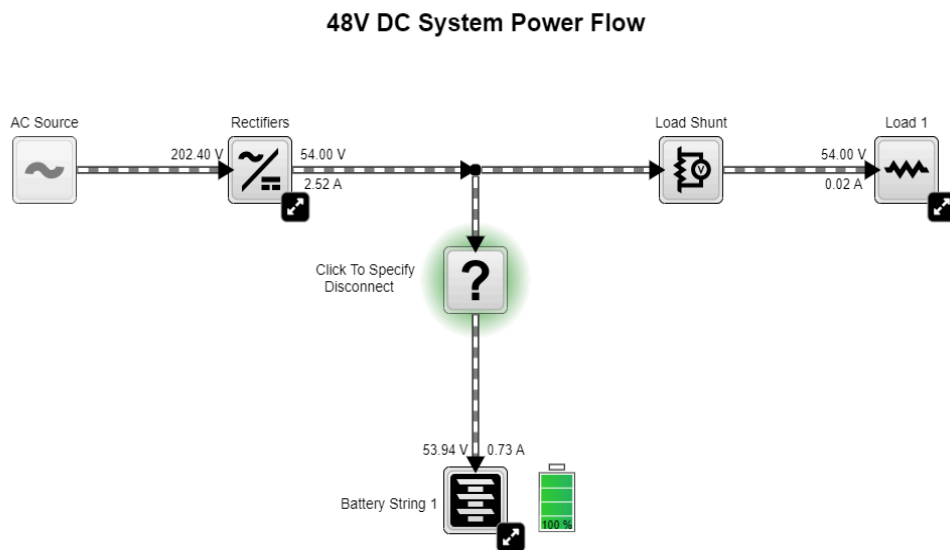

This feature can be disabled under **Controller > Settings > User Interface > Power Flow Configuration Suggestions**.

18.2.3. Configure the default power flow

If your site has multiple systems supported by **Power Flow**, you can configure a default. The chosen **Power Flow** will display whenever you select **Power Flow** in the menu.

To set or change the default **Power Flow**, go to **Controller > Settings > User Interface** and set the **Default Power Flow** field.

18.3. Interact with power flow

Power Flow is an interactive diagram, as such one can expand elements to view more information, or select element icons to navigate. The following figure highlights the interactive elements of the power flow diagram.

Figure 18-3 Interacting with power flow

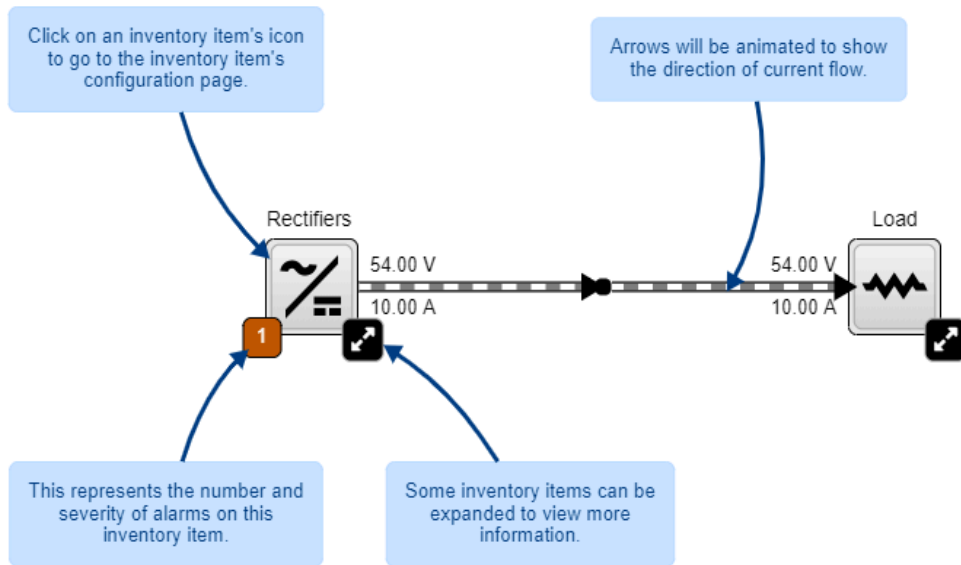

The controls are located alongside the **Help** button in the top left corner of the power flow. The **Expand All** button lets you immediately view all the details of the power flow by showing all fields and alarms. The **Collapse All** button returns the diagram to the compact status summary state.

18.4. Controller power flow

The controller **Power Flow** presents an overview on the systems configured on the site and the flow of power between them. From here you can go to the Power Flow of individual systems by selecting that system's icon.

Grayed out **Inventory** items are there to help draw a more complete picture, or can be placeholders for future systems.

Figure 18-4 Controller power flow

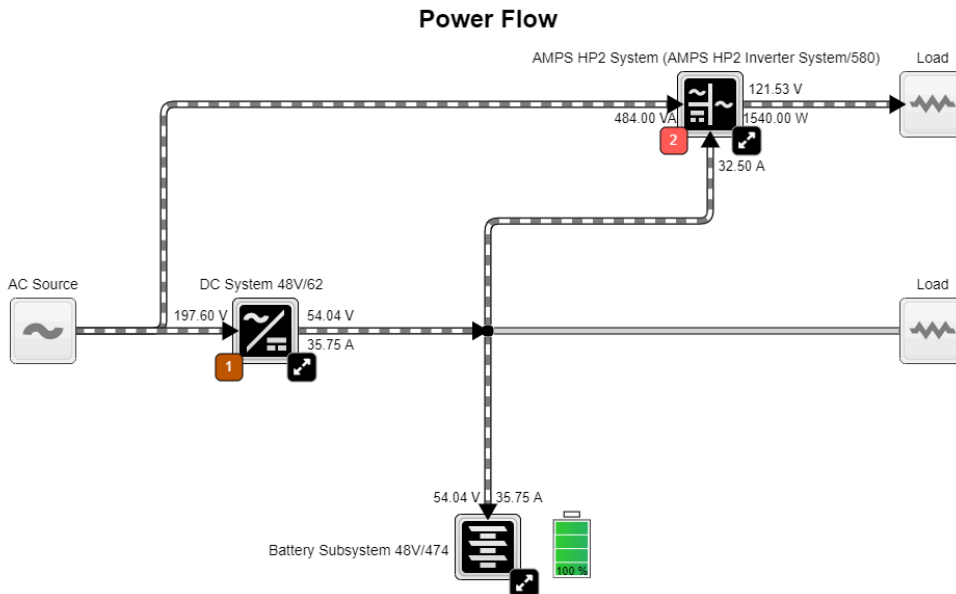

18.5. Power flow for systems managed by different controllers

For systems that are managed by different controllers but are electrically connected, **Data Sharing** can be used together with the **Controller Power Flow** to visually see the flow of power between the two systems.

Notice: In controller software version 6.20 and later, **DC and AMPS HP2 Systems** can be shared and shown on the **Controller Power Flow**.

Figure 18-5 Using data sharing to create power flow across different controllers

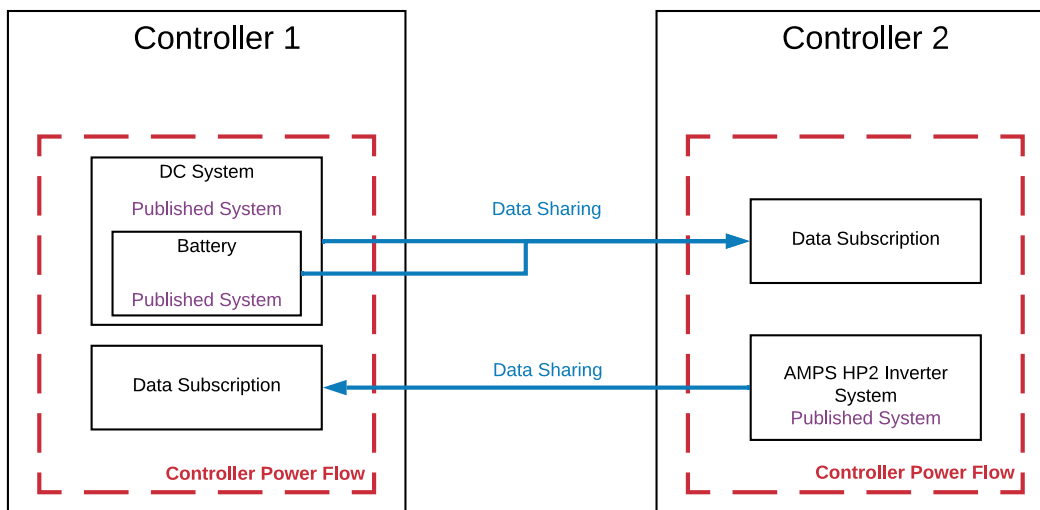

Components drawn on Power Flow that are managed by a different controller will have a reference to the **Data Subscription** from where they originate. Selecting these references will navigate to the user interface of the managing controller.

19. Maintaining the system

When maintaining your system always check for known issues within the readme file that ships with your software. This section of the document covers the following:

- Rectifier maintenance
- Inverter and T2S system maintenance
- LPS maintenance
- Batteries and battery maintenance
- LVD maintenance

19.1. Rectifier maintenance

This section covers the following: rectifier alarms, rediscovering CAN devices, and inserting unassigned modules.

19.1.1. Rectifier alarms

Possible problems with rectifiers are indicated by either a Rectifier Minor or Rectifier Fail alarm. These alarms are activated if one or more rectifiers have active alerts. Individual devices that are normally controlled as a group, such as rectifiers, have alerts instead of alarms.

Go to the *Troubleshooting* section for more detailed information on rectifier alarms and alerts.

19.1.2. Insert unassigned modules

To assign rectifiers:

1. From the main menu go to **Systems > DC System > Inventory > Rectifiers > Status**.
2. In the **Modules Available for Assignment** table, select the **Assign** button next to the rectifier you want to assign. You can also assign all the rectifiers by selecting **Assign All**. If this table is empty, there are no compatible rectifiers detected.
3. The rectifier moves from the **Modules Available for Assignment** to the **Status** table and is automatically configured to match what is contained in **Systems > DC System > Inventory > Rectifiers > Configuration** menu.

19.2. Inverter and T2S system maintenance

This section covers inverter and T2S system maintenance including: replacing, identifying, alarms and alerts, DC priority, and AC input power limit.

Change the system configuration

Once the system has been created, most of the system configuration cannot be changed. The number of phases, number of DC groups, and number of AC groups cannot be changed. If any of these values are incorrect the inverter system must be re-commissioned and all inverters unplugged.

Add or remove inverters

If more inverters are needed to increase capacity, the **Add Inverters** wizard guides users through this process.

 **Important:** *To ensure the T2S system is configured correctly, it is necessary to use these wizards to add or remove inverters from the system. This ensures that the correct number of inverters, and the correct number of redundant modules in each phase. This is important for the operation of T2S system alerts and alarms.*

Go to **Systems > Inverter System > Inventory > Inverters > Status** to access the **Add Inverters** wizard.

If inverters must be removed from the system, use the **Remove Inverters** wizard. Go to **Systems > Inverter System > Inventory > Inverters > Status** to access the **Remove Inverters** wizard.

19.2.1. Maintenance bypass

For system configurations that use a generator for the AC input, the safest way to initiate a maintenance bypass is to follow the instructions in the **Initiate Zero Phase Shift** wizard. This wizard should be used whenever the inverter system has to be put into or taken out of bypass. This prevents the inverters from turning off when the bypass switch briefly short-circuits the AC input and output.

Go to **Systems > Inverter System > System Functions > Zero Phase Shift** to access the **Initiate Zero Phase Shift** wizard.

The wizard shifts the phase and voltage of the AC output to match the input.

19.2.2. Taking power from DC source

The inverter system can take power from the DC source (usually batteries) under three conditions:

1. AC mains is lost;
2. Manual DC priority is enabled;
3. Input power limit is enabled.

When AC mains is lost, the inverters will always take power from the DC source if available.

19.2.2.1. Using manual DC priority

It is possible to manually instruct the inverters to take some amount of power from DC. This can be useful for testing or to manually reduce the AC input power during peak periods. When both **Manual DC Priority** and **AC Input Power Limit** are enabled, the feature with the higher resultant **Desired DC Input Power** will take priority. To use **Manual DC Priority**:

1. Go to **Systems > Inverter System > System Functions > Manual DC Priority**.
2. From the Manual DC Priority table, select the **EDIT** icon.
3. Select **Enable** in **Manual DC Mode** dropdown menu and select save.
4. Select the **EDIT** button to set the **Desired DC Input Power** to the desired value. This value is a percentage of output power that will be taken from DC (with the rest coming from AC input).
5. Disable **Manual DC Mode** when complete.

19.2.2.2. Use AC input power limit

The AC input power limit is a feature that allows the controller to dynamically adjust the amount of power taken by the AC input, by taking some power from the DC input. The controller will continue to take power from the AC input until a user configured power limit threshold is reached. At this point, the inverter system will begin to draw power from its DC bus. When both **Manual DC Priority** and **AC Input Power Limit** are enabled, the feature with the higher resultant **Desired DC Input Power** will take priority.

1. Go to **Systems > Inverter System > System Functions > AC Input Power Limit**.
2. Enable the **AC Input Power Limit**.
3. Set the **Desired AC Input Power** to the required value. The controller will attempt to limit the AC input power to this value by taking some power from the DC input.
4. Disable **AC Input Power Limit** when complete or when the battery needs to be charged.

The battery may be depleted and require charging.

19.2.3. Replace the fan

The fan inside each inverter has a limited lifetime. When this lifetime has expired the inverter will have an active alert called **Fan Life Elapsed**. To prevent an unexpected fan failure that could compromise system redundancy, it is recommended that the fan be replaced when this alert occurs.

To clear the alert, go to **Systems > Inverter System > Inventory > Inverters > Status**, and select the **GO TO** button of the inverter with the alert, then select the **Clear Fan Life Elapsed Alert** button.

19.2.4. Identify an inverter

If an inverter is in alert it is usually necessary to identify and locate the inverter in the rack. There are two ways to do this:

1. Go to **Systems > Inverter System > Inventory > Inverters > Status**. This view shows all inverters within the system in a table view. One column within the table displays the number of active alerts. Find an inverter with an alert and select the **Locate** button. This will cause the LEDs on the front panel of the inverter to flash for two seconds.
2. You can also select the **GO TO** button of the inverter. This view shows the bay ID, shelf ID, and slot ID of the inverter in the **Inverter Mapping** table. Normally this information is populated during system commissioning, but it can also be changed here in case it is incorrect or was not initially set.



Notice: *If these values have been set, use them to physically locate the inverter. If the values have not been set or appear to be incorrect, you can use the **Locate** button to find the inverter and set the bay ID, shelf ID, and slot ID as required.*

19.2.5. Alarms and alerts

The inverter system has a set of alarms that are generated by the alerts on the T2S system and inverters. The system alarms are shown in the **Active Alarms** table.

To see all the active alerts within the system, go to **Systems > Inverter System > Live Alerts**. This live information comes from the T2S system, and is the source of inverter system alarms.

When the inverter system has an active alarm, go to the **Live Alerts** table. The information in this table indicates which T2S system or inverter to investigate to find the cause of the alarm.

19.2.6. Replace a T2S inverter system

If a T2S system fails and needs to be replaced, remove the old T2S system and plug in the new T2S system. Go to **Modules > All Modules** and use the Replace T2S wizard to partially transfer configuration from the old T2S system to the new T2S system. It may be necessary to wait for up to 20 minutes as the new T2S system continues to be configured by communicating with the inverters.

If the system is not operating properly after waiting, then the system needs to be recommissioned for the T2S system to be configured correctly. Follow these instructions:

1. Unplug the failed T2S system.
2. Go to **Systems > Inverter System > Inventory > T2Ss** and select **Forget All in Comms Lost**. The T2S system will disappear from the table.
3. Insert the new T2S system, and then wait for it to display in the **Modules Available for Assignment** table. It will take several minutes for the controller to acquire the new T2S system. In general it is assigned to the system automatically, and displays in the **T2Ss** table. If it does not occur, use the **Assign All** button to do this manually.
4. Put the system in Bypass to keep the load powered during the commissioning process.
5. Go to **Systems > Inverter System > Configure System** and select the **Commission Inverter System** wizard in the **Configuration** table.

6. Follow the wizard instructions to recommission the system.
7. When completed, select the **Add Inverters** button to launch the add inverters wizard and add all the inverters to the system. You can also launch this wizard from **Systems > Inverter System > Inventory > Inverters > Status**.

The T2S system has been replaced, and the inverter system has no active alarms.

19.2.7. Shelf layout

Shelf layout is only available via the web interface.

When the inverters have been configured with bay ID, shelf ID, and slot ID, the **Shelf Layout** page displays a physical view of the inverters, the alert status and the output power of each inverter. The text that shows the output power is a link that opens a new page to display the inverter details.

For inverter systems that use four T2S and TUS modules; TUS modules will display in the **Shelf Layout** page, but because they do not have bay ID, shelf ID, or slot ID they are only displayed in the table.

19.3. Line power system maintenance

This section covers line power system maintenance including: replacing line power modules, and turning off power to the loads.

19.3.1. Power off and on line power loads

A line power load usually has multiple channels from different line power modules assigned to it. It may be necessary to occasionally power off then power on the load.

To power off or on a load:

1. Go to **Systems > Line Power System > Inventory > Line Power Loads** and select the **GO TO** button for the load to be powered off.
2. In the **Status** table, verify that the **Channels** value is at least 1. The **Power On/Off** buttons will only work if there are one or more channels assigned to the load.
3. In the **Configuration** table, select the **Power Off** button. After a few moments, the **Channels Enabled**, **Total Output Current** and **Total Output Power** values in the **Status** table will go to zero. This indicates that the load has been turned off. The **Power Off** button will become disabled and the **Power On** button becomes enabled.
4. To turn on the load, select the **Power On** button.

19.3.2. Replace line power modules

If a line power module is found to have failed it can be easily replaced without losing any configuration.

To replace a module:

1. Go to **Systems > Line Power System > Layout** to identify the shelf and slot of the failed module. A module causing an alarm will be highlighted with a red border. If there is more than one module in alert it may be necessary to select the channel, then select the module details link to determine the cause of the failure.
2. Unplug the failed module and replace it with a new module.
3. Select the **Forget All in Comms Lost** button in order to clear the **LP Module Comms Lost** alarm.

The new module is acquired and its channels are automatically assigned to the same load that the old module was assigned to.

19.4. Battery maintenance

This section covers the following: battery alarms, charging batteries, and maintaining batteries.

19.4.1. Battery alarms

To view the **Battery Alarms** menu go to **Systems > DC System > Inventory > Battery**.

When the battery charge current exceeds the threshold, the **Battery Charge Current High** alarm is active. The alarm may occur during battery charging if there are large load fluctuations. The alarm can also be caused by an incorrect alarm threshold or battery charge current limit setting. The alarm will clear when the battery charge current is less than or equal to the threshold minus the hysteresis.

When the highest battery temperature value rises above the threshold, the **Battery Temperature High** alarm is active. The alarm will clear when the highest battery temperature value is less than or equal to the threshold minus hysteresis.

When the lowest battery temperature value has fallen below the threshold, the **Battery Temperature Low** alarm is active. The alarm will clear when the lowest battery temperature is greater than or equal to the threshold plus hysteresis.

In a battery system, the **Battery Breaker/Fuse Open** alarm will trigger when every battery string within the battery system has a breaker or fuse that has opened.

Each battery string within a battery system has its own **Battery Breaker/Fuse Open** alarm which can go active when the battery breaker or fuse is open. The alarm can occur when the digital input that detects the state of the breaker or fuse is active. To verify configuration, the **Breaker/Fuse Source** on each battery string can be verified. This source is typically assigned to a digital input source that detects the state of a breaker or fuse. The alarm may also be caused by incorrect or faulty wiring or incorrect digital input settings. The alarm will clear when the digital input is not active.

When the battery voltage minus the midpoint voltage measurement is greater than the threshold, the **Midpoint Unbalanced** alarm is active. The alarm can be caused by an imbalance in battery cells or blocks and may indicate an equalize charge is necessary. The alarm may also be caused by damaged or end-of-life cells. The alarm will clear when the difference between half the battery voltage and the midpoint voltage is less than or equal to the threshold minus the hysteresis.

Also available in the battery **Alarms** table are the alarms related to **System Functions** related to the battery, such as Temperature Compensation, Battery Runtime, and Health.

19.4.2. Charging batteries

To access the charging menus go to **Systems > DC System > System Functions > Charging**. Note that you must have a battery defined in the DC system in order to have this menu item available under **System Functions**.

Lead acid batteries should be charged in three stages, which are constant-current charge, absorption charge, and float charge. The constant-current charge applies the bulk of the charge and takes up roughly half of the required charge time; the absorption charge, also known as topping charge, continues at a lower charge current and provides saturation, and then goes into float mode.

Charge Current Control during bulk charging helps increase battery longevity by keeping the battery current to within specified limits. Charge current to the battery during recharge will be limited to a value as programmed in the **Primary Charge Current Control** table.

This value is derived from the battery manufacturer's specification sheet.

Charge current control may at times be suspended. For example: a large negative load current that indicates a fail current sensor. When this occurs **Charge Current Control State** will read **Suspended** and **Charge Current Control Suspended Reason** will describe the reason. This information can be used in assisting with troubleshooting.

Elevated Absorption charging can be used after a prolonged AC power failure, when the battery voltage has decreased to a low level. Once the batteries have decreased beyond the absorption low voltage threshold, the controller will enter an armed mode. When AC power returns, the system voltage begins to increase, which charges the batteries.

Once the system voltage increases to the high voltage threshold, the controller begins to absorption charge the batteries at the elevated absorption voltage for a period specified in the **Absorption Charging** table.

This is done to ensure the **Elevated Absorption Timeout** is not effectively reduced by the time it takes to recharge the battery back to nominal system voltage.

Elevated Absorption charging can be terminated on the battery current to prevent over-charging of the battery. Elevated Absorption will terminate when the battery current falls below the specified threshold. Elevated Absorption charging can also be terminated or prevented from starting by setting the **Terminate/Disallow Elevated Absorption When True** setting to a custom data condition.

Upon initial activation of elevated absorption charging, the battery current is checked to see if it has fallen below the **Elevated Absorption Termination Threshold**. When the battery current falls below the threshold, and remains below the threshold for thirty seconds, the absorption charging continues at the nominal system voltage. Once the charging current is low and stable the system returns to Float mode.

19.4.3. Maintaining batteries

To view the **Battery Maintenance** menus go to **Systems > DC System > System Functions**. There are three sub menus related to battery maintenance: **Equalize and Boost**, **Battery Test** and **Battery Runtime & Health**. Note that you must have a battery defined in the DC System in order to have these menu items available under **System Functions**.

Figure 19-1 Battery maintenance system functions

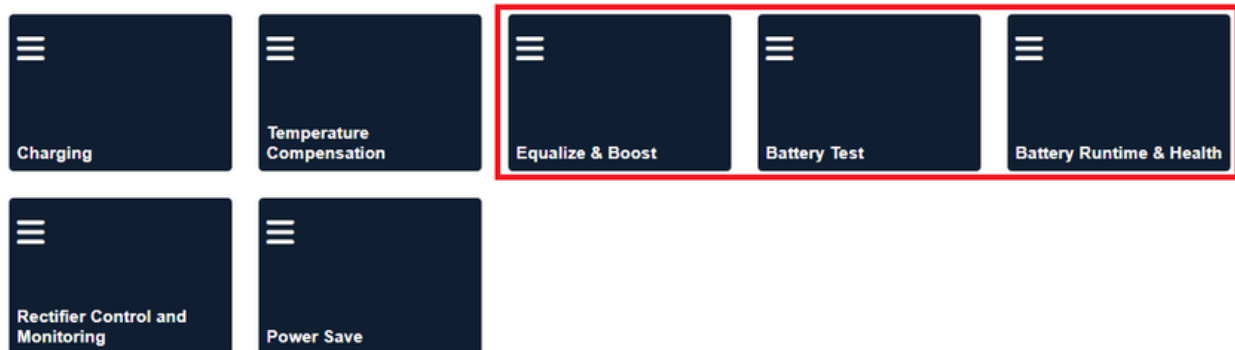

Equalize is a protective feature designed to ensure optimal lead acid battery life and performance. Over time, individual battery cell voltages may vary greatly. To ensure that batteries remain in optimum condition, they should be periodically equalize charged. An equalize charge is a forced overcharge. It removes sulfation that may have formed during low-charge conditions. This functionality can be started manually when the batteries are fully charged and floating.

Boost is similar to equalize but usually has a higher voltage. In order to start **Boost**, the **Terminate/Disallow Boost When False or '---** condition must be configured to a value to is true, or active. This is to provide a means to detect when dropping diodes have been switched into the bus first (between the rectifiers and the load), before allowing **Boost** to activate.

Refer to the battery manufacturer's recommendations.

A **Battery Test** is used to verify the health of a lead acid battery.

Battery Runtime & Health among other things, this menu provides information related to the battery's estimated state of charge (SOC), estimated runtime in the event of AC Mains loss, and estimated battery health.

A battery run time prediction is performed while the battery is supplying power to the load. The controller collects data to estimate the time it will take the battery to be drained. If the battery estimation is enabled and the battery is sourcing current to the load, the estimated battery runtime if **AC Mains** is lost displays.

During an AC outage or battery test, data is collected to calculate the estimated state of charge and the estimated health of the battery. The accuracy of this data improves as the battery undergoes more discharge cycles.

19.4.3.1. Run a manual battery test

Battery test parameters are found in **Systems > DC System > System Functions > Battery Test**. Note that you must have a battery defined in the DC System in order to have this menu item available under **System Functions**.

To run a manual battery test, the **DC System** must be in **Battery Conditioning** mode.

1. Go to **Systems > DC System > System Functions > Battery Test**.
2. In the **Configuration** table set the **Battery Test Termination Voltage** to the voltage at which the battery test should stop. A lower battery test termination voltage gives more accurate test results, but also generates more wear on the battery.

For high voltage rectifiers, or when using the rectifiers with extended voltage range, it is also important to set the **System > Inventory > Rectifiers > Configuration > Minimum Test Voltage** to a value below the **Battery Test Termination Voltage** or the rectifier may start to source current making the battery test results invalid.

3. In the **Configuration** table set the **Battery Test Timeout** to the maximum time to run the battery test.
4. In the **Configuration** table set the **Battery Test Termination SOC** the State of Charge at which the battery test should stop. A lower battery test termination SOC gives more accurate test results, but also generates more wear on the battery. The termination SOC must be less than 80 percent for the battery health estimate to work. Set Battery Test Termination on SOC to Enabled.
5. If the **DC System** is in **Battery Conditioning** mode, select the **Start Manual Battery Test** command in the **Status** table.

- The **DC System** mode should change to **Test Discharging**
- The **Time Remaining in BT** should start counting down
- The **Last Battery Test Error Condition** should have the value: **None**

19.4.3.2. Set up an automatic battery test

In addition to the **Manual Battery Test**, you can set up an interval to schedule a regular battery test. Battery test parameters are found in **Systems > DC System > System Functions > Battery Test**. Note that you must have a battery defined in the DC System in order to have this menu item available under **System Functions**.

To run an automatic battery test, the **DC System** must be in **Battery Conditioning** mode.

1. Go to **Systems > DC System > System Functions > Battery Test**.
2. In the **Configuration** table set the **Battery Test Termination Voltage** to the voltage at which the battery test should stop. A lower battery test termination voltage gives more accurate test results, but also generates more wear on the battery.

3. In the **Configuration** table set the **Battery Test Timeout** to the maximum time to run the battery test.
4. In the **Configuration** table set the **Battery Test Termination SOC** the State of Charge at which the battery test should stop. A lower battery test termination SOC gives more accurate test results, but also generates more wear on the battery. The termination SOC must be less than 80 percent for the battery health estimate to work. Set Battery Test Termination on SOC to Enabled.
5. In the **Automatic Testing** table, set the **Interval Between Tests** to the number of days (for example, 182).
6. In the **Automatic Testing** table, set the **Start Hour** to the time of day you want the test to start on (for example, 3 for 3:00am).
7. *Optional:* In the **Automatic Testing** table, set the **Days to Retry Failed Test** to the number of consecutive days to retry a battery test if it fails to start.
8. In the **Automatic Testing** table, select the **Reschedule Next Test** button to calculate the date of the next test which is shown in the **Next Battery Test** field.

The **Next Battery Test** field displays the expected date and time of the next scheduled battery test.

19.4.3.3. Run a remote battery test

Battery test parameters are found in **Systems > DC System > System Functions > Battery Test**. Note that you must have a battery defined in the DC System in order to have this menu item available under **System Functions**.

1. Go to **Systems > DC System > System Functions > Battery Test**.
2. In the **Configuration** table set the **Battery Test Termination Voltage** to the voltage at which the battery test should stop. A lower battery test termination voltage gives more accurate test results, but also generates more wear on the battery.
3. In the **Configuration** table, set the **Battery Test Timeout** to the maximum time to run the battery test.
4. In the **Configuration** table set the **Battery Test Termination SOC** the State of Charge at which the battery test should stop. A lower battery test termination SOC gives more accurate test results, but also generates more wear on the battery. The termination SOC must be less than 80 percent for the battery health estimate to work. Set Battery Test Termination on SOC to Enabled.
5. In the **Remote BT Configuration** table, set the **Trigger Input** for the digital input being used to remotely trigger the battery test.
6. In the **Remote BT Configuration** table, set **Remote BT** field to **Enabled**. Once enabled, the **Trigger State** displays a value, either **Active** or **Inactive**.
7. Activate the digital input which was configured as the **Trigger Input** and the a battery test starts.
 - The **Trigger State** in the **Remote BT Configuration** table should go **Active**.
 - The **DC System** mode should change to **Test Discharging**.
 - The **Time Remaining in BT** should start counting down.

- The **Last Battery Test Error Condition** should have the value: **None**.
- A remote battery test is started when the **Trigger Input** goes from **Inactive** to **Active**.
- A remote battery test is normally terminated when the **Trigger Input** goes from **Active** to **Inactive**. As a safety measure, the battery also terminates if the voltage drops below the termination voltage threshold or the test times out.

19.4.4. Battery temperature compensation

To view the battery temperature compensation go to **Systems > DC System > System Functions > Temperature Compensation > Status**. Note that you must have a battery defined in the DC System in order to have this menu item available under **System Functions**.

Battery temperature compensation uses the temperature probes connected to the temperature inputs on the ADIO modules which are part of the system. This feature will not function optimally if these probes are damaged or disconnected from the system.

To view the values of the temperature inputs go to **Modules**, In the **CAN Modules** table select the ADIO modules that have battery temperature probes attached. Confirm all probes are working correctly and the temperatures are reasonable.

19.5. Low voltage disconnect (LVD) maintenance

Low voltage disconnects (LVDs) are used to disconnect loads or the battery during low voltage conditions. When an LVD activates, the system displays an alarm and a message. There can be a deep discharge of the batteries during an AC fail. Discharging the battery to an extremely low voltage can cause damage to the load and to the battery. The LVD is used to disconnect the battery, or one or more loads during extremely low voltage conditions to avoid damage to the load or the battery. Once AC power returns, and the low voltage condition no longer exists, the LVD automatically reconnects the loads.

Disconnects allow you to program a number of different disconnect or connect conditions. Creating multiple LVD controls provides the capability of load shedding, which means the least critical loads are disconnected first.

Conditions that could trigger an LVD are as follows:

- Disconnect at disconnect voltage threshold; connect at connect voltage threshold.
- Disconnect at time after AC Fail; connect at connect voltage threshold.
- Disconnect when Battery SOC falls below a threshold; connect when SOC is five percent above the SOC threshold.



Notice: *If the LVD were to disconnect, the calculated SOC value displays as “- - -”. The LVD only reconnects once the SOC value is properly calculated again, which happens once the battery is reconnected and fully charged.*

- Up to three user definable disconnect and reconnect conditions.



Notice: *The connect voltage should be higher than the disconnect voltage by at least 1 V for a 48 V system and 0.5 V for a 24 V system.*

Each disconnect can have three digital inputs defined to close the loop on the status of the contactor.

- **Disconnect Open Source:** Indicates whether the disconnect is open or closed.
- **Manual Closed Source:** Disconnect is set to stay closed.
- **Manual Open Source:** Disconnect is set to stay open.

To view the **Disconnects** menu, go to **Systems > DC System > Inventory > Disconnects**.

20. Maintaining the controller

When maintaining your controller always check for known issues within the readme file that ships with your software. This section covers the following:

- Ethernet communications
- Working with alarms
- Controller maintenance
- Working with logs
- User account maintenance
- File maintenance

20.1. Ethernet communications

By default, the rear Ethernet port on the controller is configured to acquire an IP address automatically, and the front Ethernet port is configured to use a static IP address of 10.10.10.201. The LCD can be used to view and configure the IP addresses that are being used on both Ethernet ports.

To view or configure the IP addresses:

1. From the LCD main dashboard select **Shortcut** and then select **Ethernet**.
2. The LCD displays the IP address currently used on both Ethernet ports.
3. Select to highlight the row of the port you want to view or configure.
4. Select the arrow on the right-side of the screen and then LCD displays the menus: **Status**, **IPv4 Address**, **IPv6 Addresses** and **Configuration**.

To change the IP address settings:

5. Select the **Configuration** menu to highlight, then select the arrow on the right-side of the screen to enter.
6. Select **Change Network Configuration** to highlight that row, and then select the arrow on the right-side of the screen to launch the wizard.
7. Enter the desired IPv4 settings using the **Previous**, **Next**, and **Cancel** buttons.



Notice: *If you are configuring a manual IPv4 address, you must supply all four values: address, subnet, gateway, and DNS server. If you do not know the gateway or DNS server address, they may be left blank, but it is recommended to fill them in if possible. If you do not have a gateway address, it is common to substitute the number 1 for the last entry. If your IP address is 192.168.0.90, then you can set your gateway to 192.168.0.1.*

8. When complete, select **Finish** and the changes are applied.
9. Select the back arrow, on the upper-left side of the screen twice and go back to the **Ethernet** screen to confirm the new settings.

On the Ethernet screen, verify that the new IP address settings are in use.

20.1.1. Connect via the web interface

To configure the IP addresses via the web interface:

1. From the main dashboard, go to **Controller > Communication > Ethernet**.
2. In the **Ethernet** table, select the **GO TO** button on the row you want to configure.
3. In the **Configuration** table, select **Change Network Configuration** and follow the steps in the wizard.

From the **Ethernet** table, view and verify the new IP address settings.



Notice: *If you change the IP address that you are using, you will need to type the new IP address into your browser so that you can log in again.*

20.2. Working with alarms, alerts, and hints

20.2.1. Active alarms

When there are active alarms in the system, both the LCD and web interface display these alarms prominently.

Depending on how the alarms are configured, an internal speaker (if present and installed) may sound an alarm tone, and one or more relays may be activated. The internal speaker is intended to give the on-site technician audible notification that an alarm is active. The relays are intended to give external monitoring equipment notification through a relay contact closure (or opening) that an alarm is active.

On both the web interface and the LCD, the top left region of the page displays the most recent alarms in order of the highest priority. This area of the display will be red when there are critical or major alarms, yellow for minor alarms, and green if there are only warnings or no alarms. Selecting this region takes you to the **Active Alarms** table where you can get more details.

The **Active Alarms** table displays the name of the alarm, time of activation, priority, and status. The status of an active alarm can be active or acknowledged. An alarm moves from the active to the acknowledged state when the alarm cut-off (ALCO) button is pressed. The ALCO button is at the top of the **Active Alarms** table.

On the web interface there is also a small ALCO button in the **Active Alarms** region of the main dashboard that will acknowledge any active alarms, and then take you to the **Active Alarms** list.

On the LCD, ALCO can also be accessed via the **Maintenance** button on the main dashboard.

To view details of an active alarm select the **GO TO** button on the right-side of the row in the **Active Alarms** table. This screen shows you the state of the alarm, time of activation, time of acknowledgment, priority, and the relay that is mapped to the alarm. To get troubleshooting information about the alarm, select the information icon beside the row that shows the alarm state.

20.2.2. Alerts

Alerts are status information that is read from modules. An alert can only be **Active** or **Inactive** and has no user configuration.

A list of all active alerts is viewable from the **Active Alarms** page on the web interface. To view the alerts on the LCD, select the active alarm area on the dashboard. The **Alerts** button will have a count of how many active alerts are present. Alerts can also be viewed on a module details view from the **Modules** page.

Active alerts may mean that the modules are not properly configured, or in some cases may mean the module has failed.

20.2.3. Hints

A hint is information about the controller or a system that may help with how to configure the controller, or indicate the controller is in a particular state. The presence of a Hint does not necessarily indicate a problem. For example:

- When the hint is about configuration, it can offer a suggestion that may be important for system operation. Example: when battery current is not configured.
- When the hint is about status, it can act a reminder. Example: the system is operating normally and temperature compensation may be changing the system voltage.

Hints can be hidden and shown depending on whether they are relevant for the configuration.

To view the details of a hint, go to **Alarms > Active Alarms** and select the pencil icon beside the hint to be viewed in the **Hints** table. This details view will provide useful information about why the hint is being shown, and what parts of the controller may be affected. If this hint is related to configuration, there will be a button beside the **Hide Hint** button to assist in fixing the configuration issue, which will in turn make the hint go away.

20.2.3.1. Hide hints

Follow the instructions below to hide or show hints.

1. Go the screen that shows the Hints.
 - From the dashboard of the LCD, select the dashboard area, then select the **Hints** button to show any visible hints.
 - From the web interface, select **Alarms** on the main menu and view the **Hints** table.
2. Select the details button of the hint to be hidden.

3. Select the **Hide Hint** button. A pop-up will appear indicating that the hint will disappear and not appear again until something changes related to the hint, or if the **Show All Hidden Hints** button is selected. Select **Yes**.

The hint is now removed from the table.

4. To view all hidden hints again, select the **Show All Hidden Hints** button on the Hints table.

It is possible to hide all hints in the table by selecting the **Hide All Hints** button.

20.2.4. Alarm cut-off (ALCO)

The **Alarm Cut-off** (ALCO) button is used to silence the speaker (if installed) while technicians are investigating and troubleshooting an active alarm. ALCO can also be configured to deactivate alarm relays.

ALCO functionality is configured via **Alarms > Settings**.

ALCO can be configured to either:

- Acknowledge active alarms, deactivate relays, and silence speaker
- Silence the speaker only

When the **Alarm Cut-off** button is pressed, the user configured ALCO period begins to countdown. When the countdown reaches zero the ALCO period expires.

When ALCO expires the configured action is canceled. If you configured ALCO to acknowledge active alarms, deactivate relays, and silence speaker then alarms return to the active state which means the alarm relays are activated and the speaker begins sounding. If you configured ALCO to silence the speaker only, the speaker will start sounding as long as there are active alarms.

If a new alarm activates after **Alarm Cut-off** button is selected, the speaker will sound the appropriate alarm tone. Any existing alarms that have been acknowledged from a previous ALCO selection will remain acknowledged.

20.2.5. Alarm activation delay at startup

Depending on system configuration there may be some alarms that activate shortly after startup then clear a few seconds later. These nuisance alarms are often caused due to the time it takes for the controller to reacquire modules on the CAN bus. To prevent these alarms from activating and triggers relays or SNMP traps there is a setting that delays alarm activation at startup.

The alarm delay is configured under **Alarms > Settings**.

The default value of 30 seconds works for most systems, however this value can be increased to accommodate systems that have a slower start up time, that is, large inverter systems.

20.2.6. Alarm summary relays

There are three alarm summary relays that can be configured on the controller. These relays are connected to external monitoring equipment which provides a notification when the controller enters an alarm state.

- Controller critical relay
- Controller major relay
- Controller minor relay

To view them, go to **Alarms > Settings > Alarm Summary Relay**.

The relay mapped to the **Controller Critical Relay** is active whenever one or more critical alarms are active. **Controller Major Relay**, **Controller Minor Relay**, and **Controller Warning Relay** work in the same way.

20.2.7. Create user alarms

The controller has a set of default standard alarms that are associated with a system or an inventory item such as a load or a disconnect. These standard alarms may be enough to support many system configurations. It is also common to need additional alarms, based on the status of the digital inputs or on the threshold of an analog value read from the input of an ADIO module.

You can create any number of digital or threshold alarms. These alarms have the same behavior as standard alarms such as alarm cut-off, SNMP traps, and relay mapping. These user-defined alarms can be created and removed via the **Controller > Programmability > User Alarms** menu.

To create a user alarm:

1. Go to **Controller > Programmability > User Alarms**.
2. Select the type of user alarm to create. A new row for the user alarm will display in the table.
 - If you want to create a digital alarm select the **Add Digital User Alarm** button.
 - If you want to create a high or low threshold alarm select the **Add Threshold User Alarm** button.
3. Select the **GO TO** button in the alarm line item. Two tables display. One table shows the fields to configure that are specific to the selected user alarm. The other table shows the standard alarm configuration.
4. Give the alarm a descriptive name. This is important since the same type of user alarms have the same default name. The alarm description is optional.
5. Select the alarm input source. There are different options depending on the type of user alarm you are creating.

- A threshold alarm allows you select from ADIO module voltage and temperature inputs, current readings from shunts or DCCTs and any status count data about rectifiers or converters.
 - A digital alarm allows you to select digital inputs on any ADIO modules.
6. Set the priority and relay. If you want to set a severity value for the SNMP trap, use the Parameter 1 field.
 7. If you are configuring a digital alarm, this is all that is required. If you are configuring a threshold alarm, continue as described below.
 8. Select the type of threshold alarm from the **Alarm When Value** field.
 - Selecting **Above** turns this alarm into a high threshold alarm.
 - Selecting **Below** turns this alarm into a low threshold alarm.
 9. Set the threshold. For a high threshold alarm to activate, the source value must be greater than this value. For a low threshold alarm to activate, the source value must be less than this value.
 10. Set the hysteresis. The hysteresis is important when using an alarm input source that may be noisy or fluctuate periodically. Be sure to set the hysteresis large enough to avoid false alarms, but not too large to prevent the alarm from clearing properly.

The new alarm has been configured. Whenever possible, test to ensure that new alarm operates as expected.

20.3. Controller maintenance

This section covers the following:

- Restarting the controller
- Powering down the controller
- Changing the date and time
- Changing the controller language
- Changing user interface strings

20.3.1. Restart the controller

You can perform a restart via the web interface or the LCD of the controller. This first procedure covers restarting from the web interface.



Notice: *Ensure that a backup has been performed before starting this process. Use the Backup feature accessed through the LCD at **Shortcuts > Backup***



Notice: *Ensure that the controller software or operating system software is not being updated.*

To restart the controller from the web interface:

1. From the main dashboard go to **Controller > About > General**.
2. Select the **Restart Controller** button.
3. Select **Restart** when prompted.
4. The **Controller Restart** window displays progress via a progress bar.
5. The controller screen goes black, and the LEDs cycle while restart is in progress.

Once complete, the login page displays on the web interface, and the Cordex® HP logo displays on the controller.

20.3.2. Restart the controller via the LCD

Notice: *Ensure that the controller software or operating system software is not being updated.*

To restart the controller via the LCD:

1. From the main dashboard of the controller, select **Shortcuts**, then select **Restart**.
2. Select the **Execute** button to confirm.

The front screen blacks out, and the LED status lights cycle until the restart is complete. Once the restart completes, the Cordex® HP logo displays.

20.3.3. Powering down the controller

Sometimes it may be necessary to power down the controller to replace, remove, or repair rectifiers.



Notice: *You must use the LCD or web interface to reset the controller. This ensures that recent changes and files are saved properly.*

1. From the main dashboard on the web interface, go to **Controller > About > General** and then select controller reset.

- or -

2. From the main dashboard on the LCD, select **Shortcuts**, then select **Reset**.
3. Select **Execute** to confirm.
4. While the controller LEDs are performing a chase pattern, power down the controller by removing the power pin on the right-side of the controller.

After a reset, the controller LEDs will perform a chase pattern that indicates that the controller is booting. It is safe to remove power while the controller is booting. Once that chase pattern stops, the boot sequence is over and it is no longer safe to remove power.

20.3.4. Change the time and date

There are three options to change the date and time:

- Manually with the date/time picker
- Using the local browser/computer
- Using simple network time protocol (SNTP)

To set the date and time:

1. Go to **Controller > Settings > Time & Date**. In the **Time & Date** table, select the **EDIT** button on the **Time Zone** row.
2. From the dropdown **Time Zone** menu, select your time zone, and then select **Save**.
3. If setting the time manually, select the **EDIT** button on the **Current Time and Date** row. Use the date/time picker to change the date and time.
4. If setting the time and date with the local browser select **Synchronize Time and Date to Web Browser**. This reads the time from the browser and sends it to the controller.
5. If setting the time and date using SNTP, first enter a valid SNTP server address (DNS name or an IPv4 / IPv6 address), and then select **Synchronize Time and Date to Network Time Server**. If you do not want to use the SNTP server, clear the **Network Time Server Address** field.

It is common for gateways and routers to also be SNTP servers. If you are unsure of a valid SNTP server address, try using the controller's assigned gateway/router address. If this does not work, consult your IT personnel.

The controller time and time zone have been correctly set.



Notice: Whenever the time or time zone has been changed, an entry is recorded in the event log.

20.3.5. Change the language for the LCD

To change the default login language from the web interface:

1. Go to **Controller > Settings > User Interface**.
2. In the **LCD Preferences** table, find the **LCD Language** row and select the **EDIT** button.
3. From the dropdown menu, select your language preference, and then select **Save**.

20.3.6. Change the language for the web interface

To change the default language for the web interface:

1. On the log in screen, in the top-right corner, select the dropdown menu and select language preference.
2. Alternatively, after a successful login, select the dropdown menu in the top-right corner of the website and select language preference.

20.3.7. Change user interface strings

In rare occasions it may be desired to change some of the strings displayed on the user interface to conform to local terminology standards. The controller allows a user to download a strings file that can be edited in a spreadsheet program. The strings file can then be uploaded to the controller and after a restart, the changed strings will be used.



Note: Use of this feature must be approached with caution as it may result in undesired consequences:

- *Editing the strings requires familiarity with a spreadsheet program in order to correctly import the file and save the file with UTF-8 encoding.*
- *Edited strings that are longer than the original can distort the user interface and make navigation difficult.*
- *Spelling or grammar errors can make the user interface hard to understand.*
- *Uploading an incorrectly generated strings file can result in unexpected or missing strings that make the interface unusable.*
- *The changed strings can result in confusion when seeking technical support since the user interface may be unfamiliar to support personnel.*
- *Strings on the OLED display cannot be changed.*

To change one or more strings on the user interface:

1. Go to **Controller > Settings > User Interface**.
2. In the **User Interface Preferences** table, select the **Export All English Strings** button. The file will be downloaded to the PC (when using the web interface) or to a USB drive (when using the LCD). It is also possible to only export previously uploaded user strings by selecting the **Export User Strings** button.
3. Import the file as a UTF-8 encoded CSV file to a spreadsheet program. Failure to do this may result in missing or unexpected strings.
4. Make the necessary edits to the strings in the second column. Do not change anything in column 1 or strings may not be imported as expected.
5. Save the file as a UTF-8 encoded CSV file. Failure to do this may result in missing or unexpected strings.
6. Select the **Import User Strings** button and select your strings file. If using the LCD, the uploaded filename must contain the word “strings” and end in “.csv”.

7. Restart the controller to load the new strings.
8. On startup, the new strings will be loaded. Any errors found while loading the new strings will be logged into the event log.

When interacting with technical support, you may be requested to hide the user strings from the user interface. To do this go to **Controller > Settings > User Interface** and change the **Visibility of User Strings** setting to **Hide User Strings**. Restart the controller. The strings can be shown again by changing the setting to **Show User Strings** and restarting the controller.

20.3.8. Change the web session language

To support situations where users want different language options, you can change the language used for a specific login session. Most corporate security policies ban the storage of browser cookies, which means that the browser will not remember your selection from login to login so you need to select your web session language each time you login.



Notice: *Without cookie support, if you force a refresh (**F5** for most browsers), the browser will not remember the language selection and you will need to change the web session language again.*

To change the web session language:

1. Go to the top right corner of the webpage.
2. From the **Language** dropdown menu, select your language preference.

20.3.9. Change the system status bar

By default, the controller dashboard displays your systems in the original order created, from left to right. The **System Summary Option** is **Automatic** by default but can be customized to display up to four systems slotted in any order required. This is done via the **System Summary Option**, in the **Web UI Preferences** table.

To customize the system status bar view:

1. Go to **Controller > Settings > User Interface**.
2. In the **Web UI Preferences** table, select **System Summary Option**.
3. From the **System Summary Option** dropdown menu, select how many systems to display, and then select **Save**.
4. To change which system displays in the left most area of the system status bar, select the **EDIT** button for first system, and then select an option from the dropdown menu.
5. Continue to assign systems to the second, third, and fourth slots as required.

The system status bar displays the selected systems in the order selected.

20.3.10. Change the dashboard values

It is possible to change the values that show for a system on the **System Status Bar**, the **LCD Dashboard**, and the **Web UI Dashboard**.

To change which values appear for a system:

1. Go to **Controller > Settings > User Interface**.
2. Look at the table for the system you wish to configure (DC System 48V Dashboard Values for example).
3. Select the **EDIT** button beside the **Dashboard Value** you would like to edit.



Notice: *The values in this table will appear on the different dashboards in the order they appear in this table (for example, **Dashboard Value 1**, then **Dashboard Value 2**, ...). To change the order, set the fields in this table in the desired order.*

4. Select the value to show for this **Dashboard Value**, then select **Save**.

The new value selected will appear in the position of the **Dashboard Value** that was configured.

20.3.11. Data sharing

The Data Sharing feature allows to share individual data point, or select systems between controllers. This data sharing feature consists of two parts:

- Published data
- Data subscriptions

Data sharing can be useful in situations where systems were installed at different times. These systems may have different controllers, but share the same bus (for example, a DC system was installed, then later-on, an AMPS system was installed, each with their own controllers).

Using this feature, the AMPS system controller provides the DC system controller with data on how much DC input current it will require during an outage.

The DC system controller provides the AMPS system controller with data on how much runtime the battery has remaining.

20.3.11.1. Share published data and systems

Each controller can publish ten data points and up to five systems which other controllers can read and use for various purposes.



Notice: *Currently the data points are limited to numeric data and only DC and AMPS HP2 systems can be published.*

To share which published data or which published systems should be shared with other controllers:

1. Go to **Controller > Communication > Data Sharing > Published Data and Systems**.
 - **Published Data:** Select the **EDIT** button next to one of the published values.

Select the data point to be shared with other controllers, then select **Save**.
 - **Published Systems:** Select the **EDIT** button next to one of the published values

Select the system to be shared with other controllers, then select **Save**.
2. This process can be repeated to share multiple data points or systems with other controllers.

After performing the above procedure, other controllers will be able to subscribe to this controller to receive data from it.

20.3.11.2. Data subscriptions

Data Subscriptions are a way for users to read and use **Published Data and Systems** from other controllers.

To configure a **Data Subscription**:

1. Go to **Controller > Communication > Data Sharing > Data Subscriptions**.
2. Select **Add Data Subscription**.
3. Select the **GO TO** button of this newly created **Data Subscription**.
4. Select the **EDIT** button beside **IP Address**, enter in the IP address (DNS name or an IPv4 / IPv6 address) of the controller to read data from, then select **Save**.

After configuration, the **Data Subscription** will start reading any configured **Published Data and Systems** from the remote controller. Data will be read and updated every ten seconds.

If there are any problems communicating with the remote controller, those will be indicated in **Communication Status**, potentially being raised as an alarm through the **Communication Error** alarm. Some common errors could be:

- IP address configured incorrectly.
- The controller or the remote controller are not connected to any network, not connected to the same network, or not publicly visible.
- No published data configured on the remote controller (this will be indicated as a **No Published Data** status).

20.3.12. Maintenance mode

As of controller software version 7.40, a feature called **Maintenance Mode** is available on the controller. This feature is intended for users who want to communicate to other users that the controller

is undergoing maintenance, and can also be used to inhibit the alarm summary relays during the maintenance.

At its simplest, **Maintenance Mode** provides an alarm, which has the behavior inherent to controller alarms. It can be mapped to a relay, or monitored via the web interface, LCD, or SNMP. This can be used to signal other users that some maintenance is being performed on the system. Using the relay or SNMP interfaces, external systems can be notified of the maintenance.

Maintenance Mode also provides an option to **Inhibit Alarm Summary Relays During Maintenance**. If a user chooses to enable this feature, any relays which are in use as Alarm Summary Relays will be inhibited during maintenance. This allows a user to do maintenance which may cause alarms without the Alarm Summary Relays being activated. Relays that are not mapped to Alarm Summary Relays will not be affected and will behave as usual. One caveat is that if the same relay is mapped to both an Alarm Summary Relay and the Maintenance Mode alarm itself, that particular relay will not be inhibited, as it is possible that external systems would be using this relay to determine whether the maintenance mode is active.

While the system is not in Maintenance Mode, the **Status** of the feature will be **Inactive**. Users can have the maintenance mode triggered automatically, or they can start it manually by a button press. To use the automatic trigger, the **Trigger Source** must be mapped to a digital input, custom data value, or other boolean system value. If Maintenance Mode is started automatically using this trigger, the status of the feature will be **Started by Trigger**. Alternatively, the user can select **Manually Start Maintenance Mode** to start the mode manually.

Maintenance Mode must be stopped in the same way it was started. If it was started by trigger, **Manually Stop Maintenance Mode** will be disabled until the trigger is false and Maintenance Mode is once again **Inactive**. If Maintenance Mode is started manually via button press, the status will be **Manually Started**. Note that if Maintenance Mode is already started by the trigger, the button to start it manually will be disabled. Similarly, if Maintenance Mode is started manually, any changes to the trigger status while Maintenance Mode is **Manually Started** will be ignored until the mode has been manually stopped via button press.

On the **Maintenance Mode** page, there is a table titled **Relay Behavior During Maintenance**. This table will show all the relays in the system and their expected behavior when Maintenance Mode is active. If **Inhibit Alarm Summary Relays During Maintenance** is set to **No**, all relays in this table should show **Not Inhibited (Inhibit Disabled)**. If the user does want relays to be inhibited during maintenance, set the **Inhibit Alarm Summary Relays During Maintenance** option to **Yes**. Once that is done, the relay table will be updated to show how this affects each relay in the system. Most relays will still behave normally, and so their entry in this table will read **Not Inhibited**. The relays that are mapped to the Alarm Summary Relays will read **Inhibited (Alarm Summary Relay)**. If a relay has been mapped to the **Maintenance Mode Active** alarm, the entry will read **Not Inhibited (Maintenance Mode Relay)**. The same information is available on each individual relay page.

20.4. Working with logs

This section covers the following:

- Events and alerts log
- Battery log
- Power outage log
- Datalogs
- Performance log

20.4.1. Event and alert logs

Figure 20-1 Events Log

Time	Source	Name	Value
January 10, 2023, 12:22 PM	Web User	Logon	admin
December 22, 2022, 2:53 PM	WebSession	Session ended (Http Request Timeout)	10.121.250.4
December 22, 2022, 2:50 PM	WebSession	Session ended (Http Request Timeout)	10.121.250.4
December 22, 2022, 2:49 PM	Web User	Logon	admin
December 22, 2022, 2:49 PM	Web User	Failed Logon	admin
December 22, 2022, 2:49 PM	Web User	Logon	admin
December 16, 2022, 1:36 PM	Test Site 1 (Controller)	Restore Point Description	Set to: Auto-generated
December 15, 2022, 2:21 PM	WebSession	Session ended (Http Request Timeout)	10.121.100.210
December 15, 2022, 1:37 PM	Battery 220V/706	Battery Mode	Float
December 15, 2022, 1:37 PM	Web User	Logon	admin

Events

The **Event** log table keeps a record of changes to the state of the system to help with troubleshooting. The types of state changes that are logged include:

- Alarm states
- Configuration changes
- Battery Mode changes (for example, discharging)

To view the **Event** log, go to **Logs > Events & Alerts**.

Events are stored in a 'first in first out' (FIFO) buffer holds up to 3000 events. Of the most recent events, up to 25 can be viewed on the LCD, and up to 300 can be viewed via the web interface. From the web interface, all 3000 events can be exported as a CSV file.

To export an Event log go to **Logs > Events & Alerts**, and select the **Export** button at the top of the **Event** table.

Module alerts

The **Modules Alerts** log table tracks what is happening on individual modules without interfering with **Alarms** or the **Event** log.

20.4.2. Battery log

The **Battery** log records the duration and change in capacity (Ah) for every charge and discharge of a battery. If you have **Battery Runtime & Health** enabled, the log will also record the change in **State of Charge (SOC)** and **State of Health (SOH)**.

Because of the large quantity of information that can be collected for battery charges and discharges, a complete dataset can only be obtained by exporting the log. The following three figures provide examples of the data.

When viewed on the LCD, the log shows time, activity type, duration and amp hours delivered.

When viewed on the web interface, the log includes the battery ID, battery capacity, state of charge, state of health, and the activity results.

When exported to a CSV file, the log includes the Peukert exponent, starting and ending voltages plus the minimum, maximum and average battery currents and temperatures.

The battery log will hold up to 300 entries in a FIFO. When viewing entries on the LCD, up to 25 can be viewed. All 300 entries may be viewed on the web interface or exported to a CSV file.

Figure 20-2 Battery log on the web interface

Battery Identifier	Battery Activity	Start Time	Duration (h)	Battery Capacity (A.h)	Amp Hours Delivered (A.h)	Change in SOC (%)	Starting SOH (%)	Change in SOH (%)	Battery Current - Avg (A)	Activity Results
Battery 48V/115	Charge	January 4, 2023, 4:58 PM	0.03	100.0	0.0	---	---	---	1.8	Normal
Battery 48V/234	Charge	January 4, 2023, 12:40 PM	0.07	110.0	0.2	---	100.0	---	3.2	Normal
Battery 48V/234	Discharge	January 4, 2023, 12:39 PM	0.02	110.0	-0.2	0.0	100.0	---	-9.0	Normal
Battery 48V/234	Charge	January 4, 2023, 12:08 PM	0.04	110.0	0.2	---	100.0	---	4.5	Normal
Battery 48V/234	Discharge	January 4, 2023, 12:08 PM	0.00	110.0	-0.1	0.0	100.0	---	-29.6	Normal
Battery 48V/234	Charge	January 4, 2023, 12:03 PM	0.06	110.0	0.3	---	100.0	---	5.3	Normal
Battery 48V/234	Discharge	January 4, 2023, 12:02 PM	0.02	110.0	-0.6	0.0	100.0	---	-28.8	Normal
Battery 48V/234	Charge	January 4, 2023, 12:01 PM	0.00	110.0	0.0	0.0	100.0	---	0.0	Interrupted by Discharge
Battery 48V/234	Charge	December 23, 2022, 10:58 AM	0.02	104.0	2.2	0.0	100.0	---	119.2	Normal
Battery 48V/234	Charge	December 22, 2022, 1:33 PM	0.07	104.0	0.3	---	100.0	---	4.6	Normal

Figure 20-3 Battery log in Excel

Battery Identifier	Battery Activity	Start Time	Duration (h)	Battery Examination	Battery Capacity (Ah)	Amp Hours Delivered (A.h)	Starting Voltage (V)	Ending Voltage (V)	Starting SOC (%)	Change in SOC (%)	Starting SOH (%)	Change in SOH (%)	Peukert Exponent	Battery Current - Min (A)	Battery Current - Avg (A)	Battery Current - Max (A)	Battery Temperature - Min (°C)	Battery Temperature - Avg (°C)	Battery Temperature - Max (°C)	Activity Results
Battery String/7887	Charge	11/2/2016 12:18	1.58	Enabled	42	8.6	26.7	27	73.5	20.7	84.2	---	1	1.2	5.4	37.9	25	26	26	Normal
Battery String/7887	Discharge	11/2/2016 11:58	0.34	Enabled	42	-9.4	27	24.2	100	-26.5	85	-0.8	1	-27	-27.2	-28.4	25	25	26	Normal

20.4.3. Power outage log

The **Power Outage** log records time and duration of every power outage to the system. If you have **Battery Runtime & Health** enabled, you can refer to the Battery log to determine the change in **State of Charge (SOC)** and **State of Health (SOH)**.

When viewed on the LCD, the log shows start time, end time, and time and duration of each power outage.

When viewed on the web interface, the log includes the system ID, start time, end time, and duration of each power outage.

When exported to a CSV file, the log includes the system ID, start time, end time, and duration of each power outage.

20.4.4. Datalogs

Datalogs allows users to record measurements (**Data Signals**) at set intervals over a period of time. The **Datalog** uses the controller sensors and calculated values as inputs. The controller supports up to ten **Datalogs**, each of which may be recording up to 20 **Data Signals**.

The interval between samples can be configured, as well as the number of samples collected. When the maximum number of samples have been collected, the newest sample replaces the oldest sample. Data capture can either be started and run continuously or an equation can be used to control data capture.

Datalogs are saved to the file system when the controller is reset by a user, as well as being automatically saved once every day. If power is lost to the controller, there is potential for some data loss.

If any **Data Signals** are not configured, a **Datalog** will not start.

If there is a **Clock Error Alarm**—which means that the date has not been set, a **Datalog** will not start.

If a **Datalog** is running and a controller reset occurs, the **Datalog** will try to resume data collection on controller startup.

If there is data available, a **Preview Chart** displays up to 30 samples. If there are more than five **Data Signals**, only the first five signals are displayed in the preview. If a value is unknown, it is displayed on the preview as a zero value.

20.4.4.1. Create a datalog

There are three stages to setting up a **Datalog**:

- Add a **Datalog**
- Add the **Data Signals**
- Run the **Start Capture** command

To create a **Datalog**:

1. Go to **Logs > Datalogs** and select **Add Datalog**.

Up to ten dataloggs can be created.

2. Select the **GO TO** button of the new **Datalog**.

3. From the **Configuration** table, select the **EDIT** button to setup the following information:

- a. **Name:** The Datalog name.
- b. **Description:** Describe the purpose or usage of the Datalog.
- c. **Number Of Samples To Capture:** From 60 to 3600 samples.
- d. **Sampling Method:**

Datalogs can be configured to either **Sample at Fixed Time Intervals**, or **Sample on Trigger Data Signal Change** in which case a new sample of all Data Signals will be taken only when the **Trigger Data Signal** changes by more than the **Trigger Data Signal Deadband** compared to its value when the previous sample was taken.

- e. **Sample Interval:** Set the interval from 2 seconds to 3 hours (10800 seconds).
- f. **Trigger Data Signal:** The Data Signal which triggers sampling, when the Sampling Method is set to Sample on Trigger Data Signal Change.
- g. **Trigger Data Signal Deadband:** Determines how much the **Trigger Data Signal** has to change before a new sample is taken.
- h. **Capture When True:** Controls whether data is captured continuously or only under certain conditions.

If the **Capture When True** value goes unknown, the Datalog will ignore it. If the Datalog is in the waiting state (or the sampling state), when the **Capture When True** value goes unknown, the Datalog will stay in its current state, either waiting (or sampling) state.

4. From the **Data Signals** table, select **Add Data Signal** to add the number of data signals you need.

Up to 20 signals can be created.

5. From the **Configuration** table, select the **EDIT** button to setup the following information for each **Data Signal**:

- a. **Name:** The signal name.
- b. **Description:** Document what the signal means or how its value should be interpreted.
- c. **Field:** Bring up the field picker and select the ADIO module input or other value you want to monitor.

You cannot leave data signal fields unknown. You cannot select state or boolean values for data signals.

6. Run the **Start Capture** command.

If all of the **Data Signals** are not configured when the Start Capture button is pressed, the capture will still start, but an entry is made in the event log to indicate a Data Signal is not configured.

You can configure the **Datalog** to run at certain times of day, or to stop after a certain time or number of samples, by configuring a boolean **Custom Data** and then configuring **Capture When True** to use it.

If you change the **Data Signals**, **Sampling Method**, **Trigger Data Signal**, **Trigger Data Signal Deadband** or **Number Of Samples To Capture**, that will make the old data is incompatible with the new data. The old data will be deleted when you run the **Start Capture** command.

20.4.4.2. Transfer datalogs configuration to other controllers

By importing and exporting a configuration file, some datalogs configuration can be transferred to a new controller. A datalog sources information from data signals coming from various physical measurements on its system, and the data signal will only transfer to a new controller if that measurement also exists on the new system.

For example, the Total Load Current is an attribute of the DC system. A datalog measuring the Total Load Current will only transfer to the new controller if it has a DC system in its inventory.

However, signals such as a rectifier's ambient temperature measurement are attributes of that specific rectifier. If a configuration file is exported from one controller and imported onto another, the ambient temperature data signal will not import, and it will raise an **Invalid Config Ignored** event. The new rectifier will need to be re-configured to the new controller.

20.4.5. Performance logs

The **Performance Log** holds up to one-year's worth of daily roll-ups with a minimum, maximum, and average value for key usage statistics. For systems, this includes: input voltage and current, and the output voltage and current. For the controller, the CPU and memory usage are tracked.

To create the daily roll-ups, the **Performance Log** is rolling up second data into minute data, minute data into hour data and hour data into daily data. The web interface displays previews of all four sets of data as they are collected. In these previews, the horizontal axis shows the data sampled, not the time stamp. Daily statistics with minimum, maximum, and average values can be exported for each log by selecting the **Export data to CSV** button under the **Days** graph. Or you can export every log by selecting **Export All** via **Logs > Performance Logs**.

If the controller is shut down for some period of time, the preview window will not show the gap in time.

If there is a clock error, indicating that the time and date is unknown, a **Performance Log** will not collect data.



Notice: *The performance log for the **DC System Total Rectifier O/P Current** has an additional table **Top Hourly Averages** that shows the top-three hourly averages and timestamps for the system total rectifier output current. This table does not exist on any other performance log.*

20.5. File maintenance

This section of the manual covers the following:

- Using file preferences to name files
- Upgrading the controller operating system via the LCD
- Upgrading the controller software
- Configuration restore points
- Importing and exporting configuration files
- Exporting diagnostic information
- Importing and exporting license keys
- Exporting a snapshot of controller and system status

20.5.1. File preferences

If working with multiple systems, use the file naming options to keep your files organized. You can add the controller name or the date to exported and saved files.

If adding a date, the date string format is YYYY-MM-DD making it easy to sort in file browsers.

If adding the controller name, and that name contains whitespace, illegal characters for file names or some extended characters, those characters will be removed from the string that is added to the filename. This naming convention applies to most files that can be saved or exported from the controller for example: configuration files, log files, licensing files, and backup files.

To append a name or date:

1. Go to **Controller > Settings > User Interface**.
2. In the **File Preferences** table,
 - Select the **EDIT** button in the **Append a Date String to Filenames** field to enable the add date to filenames.
 - Select the **EDIT** button in the **Change the Add the Controller Name to Filenames** field to add the controller name to filenames.

20.5.2. File maintenance from the LCD

To enable more to be done with the LCD and USB mass storage devices, most of the file maintenance functions available via the web interface are available on the LCD. LCD file operations take place using the top-level or root directory of a FAT32 formatted USB drive.

File operations that are available on both the web interface and LCD are as follows:

- **Import** and **Export** of configuration files.
- **Upgrade** of the controller application software.
- **Upgrade** of the controller operating system software.
- **Import** and **Export** of license key files.
- **Upgrade** of module application software using ACAN files.
- **Downloading** of event logs and module alerts.
- **Export Backup** of the controller application software and configuration.

File operations that are available only via the LCD:

- **Restore** of the controller application software and configuration.

File operations that are available only via the web interface:

- **Downloading** of performance logs, datalogs, and tables.

20.5.2.1. Import and export from the LCD

On the LCD, go to **Menu > Controller > Files & Upgrades > Configuration & Software Backup > Configuraton File**. The **Export Controller Clone** command allows you to export the entire controller configuration to a connected USB drive. The other options **Export System or ADIO** and **Export Partial** are not supported on the LCD. The **Import** command allow you to import configuration files with limitations as noted.

Alternatively, go to **Shortcuts > Browse USB**. Here you can select a configuration file to perform an **Import**.



Notice: Using the **Import** command from the LCD has limitations. Importing a configuration file that is a clone of a controller will always work. However, importing a configuration file that is for a system, an ADIO module or a partial configuration will only work if the import can be achieved unambiguously. For example, if the import is intended to change some configuration for an ADIO module, but there are more than one ADIO module of the same type it will be ambiguous as to which ADIO module should receive the configuration. Therefore the import will fail. In this scenario, the web interface should be used to do the import so that the user can choose which ADIO module should receive the configuration.

20.5.2.2. Application upgrade from the LCD

There are two ways to upgrade the controller software:

1. On the LCD, go to **Menu > Controller > Files & Upgrades > Software Upgrade**. The **Upgrade New Controller Software and Reboot** command will allow you to upgrade the application using an appropriate upgrade file.
2. On the LCD go to **Shortcuts > Browse USB**. You can upgrade the controller application via an appropriate upgrade file that has been stored on a USB drive.

The application upgrade takes several seconds. The controller reboots automatically when complete.

20.5.2.3. Operating system upgrade

On the LCD, go to **Shortcuts > Browse USB**. You can upgrade the controller operating system via an appropriate upgrade file that has been stored on a USB drive.



Notice: *There must be at least 33 MB of free space to upgrade the operating system. To check the available free space, go to **Controller > About > Storage & Memory**. In the **Application Storage** table, check the **Free Space** row.*

The operating system upgrade takes several minutes. The controller reboots automatically when the upgrade completes.

20.5.2.4. Backup and restore from the LCD

The **Backup** command allows you to make a full backup of a system so that it may be restored to a known state. To access the **Backup** function on the LCD, go to **Shortcuts > Backup**.

The **Restore** command allows you to take a previously created backup file and restore the contents of that file to the system. All existing application software and configuration information will be deleted and replaced by the contents of the backup file. To access the **Restore** function on the LCD, go to **Shortcuts > Restore**.

See section *Backup and Restore* for additional information and procedures.

20.5.3. Upgrade the controller software

To perform a controller software upgrade:

1. Go to **Controller > Files & Upgrade > Software Upgrade**.
2. Select the **Upload New Controller Software and Reboot** button.
3. From the **Upload File** window, select **Select File**, and then select the upgrade file.
4. Select **Upload** to begin upgrading.
5. After the upgrade is finished, the controller will restart automatically.

Once complete, the **Login** page displays and you must log back in to the controller.

After an upgrade, it is common to see a number of Event Log entries showing configuration fields being set. This is normal on an upgrade when the system needs to set up new features or options that have been added.

20.5.4. Export a configuration file

There are three options when exporting a configuration file.

Export Controller Clone: Is used to transfer the entire configuration. A common use for this type of export is to make a back-up of the current settings. When using this export, almost all information is saved to the exported file. See the following note for an explanation of what is not included in the export file.

Export System or ADIO: Is a way to copy a system or an ADIO module to another controller. Only a single system or an ADIO module may be selected. If selecting system, any ADIO module referenced by that system is also exported. For example, if an Cordex® CXC HP L-ADIO peripheral is used for voltage measurements and Cordex® CXC HP 6i-ADIO peripheral is used for shunt measurements they are saved to the export file.

Export Partial: Is used to select a specific set of information for export. This is commonly used for transferring user alarms, custom data, alarm thresholds or other configured data that may need to be common between controllers. A partial export must be performed on a set of related configurations. The wizard allows you to select either a controller, one or more system or ADIO modules. After the selection is made, all associated configurations are presented in a list and are exported by selecting the check-box. For example: to export a set of custom data, select controller; to export a set of DC System alarm configurations, select the required system from the dropdown list. If any of the selected configuration references an ADIO module, that ADIO module is also exported.

Some items must be exported as a whole. This includes items that can be created and removed by a user (other than systems) or items that are permanent to the controller. For example if selecting:

- **Controller:** You can export a whole SNMP destination, but not a particular configuration within a destination; or if exporting custom data, you can export a whole custom data with all its variables, but not a specific variable defined within the custom data. The same applies to user alarms, datalogs, schedules.
- **DC system:** You can export a whole battery, load, shunt, or disconnect, but not the configuration within these items.
- Multiple systems of the same type such as line power system cannot be exported in the same configuration file.



Notice: *Some configuration cannot be exported:*

- *Controller description and location information (this is unique to each controller)*
- *IP configuration (to avoid loss of Ethernet connectivity)*



- *Web server port configuration (to avoid loss of Ethernet connectivity)*
- *Line power channels (unique to line power modules)*
- *Power module (power modules are unique to a system)*
- *Users (to maintain password security)*
- *Server passwords (for example, email server password; to maintain password security)*

To export settings:

1. From the main dashboard go to, **Controller > Files & Upgrades > Configuration & Software Backup**.
2. Select the type of export required:
 - **Export Controller Clone:** A file is generated and uploaded to your browser.
 - **Export System or ADIO:** A wizard displays in which you can select a System or an ADIO module. Select an item to export and then select **Next**. Use the **Download File** option to save your export file.
 - **Export Partial:** A wizard displays in which you can select a configuration source, select **Next**. In the **Select Configuration to Export** window, select each configuration item for export, select **Next**. In **Select Another Configuration** window, select **Yes** and select **Next** to select another configuration source. Select **No** and select **Next** when all configuration item are selected. Once the configuration file is prepared, use the **Download File** option to save your export file.
3. To help distinguish among configuration files rename your export file with a unique identifier. This can important when making a back-up files for archiving or if a controller replacement is required.

20.5.5. Import a configuration file

When importing a configuration file, the controller will analyze the file to determine the type of import to perform. There are three types of import corresponding to the three types of export.

Clone

Clone is performed when a file that has been exported using **Export Clone Controller** is uploaded. The configuration of the controller is matched to that contained in the file. In addition all existing systems, custom data, timers, counters, datalogs are removed. Clone is also performed if a configuration file from a version previous to version 4.00 is uploaded.

Copy system or ADIO module

Copy system or ADIO module is performed when a file that has been exported using **Export System or ADIO** is uploaded. The system or ADIO module contained in the file is added to the controller. If a system is being imported, the new system is created and added to the controller under the **System** menu. If importing a DC System and a DC System already exists the import will fail because only one DC System is supported. It is necessary to first delete the existing DC System before doing the import. This also applies to Converter Systems. All other types of systems do not have this limitation. If importing an ADIO module, the ADIO module is added under the **Modules** page. After importing the ADIO module, use the **Replace ADIO** command to transfer the configuration of the imported ADIO module to an existing ADIO module.

Partial import

Partial import is performed when a file that has been exported using **Export Partial** is uploaded. The configuration contained in the file replaces that of any matching existing configuration settings. It is possible that the destination of the imported configuration cannot be automatically determined. For example, if configuration for a Line Power System is imported and there exists more than one Line Power System, the user will be required to select the which system should receive the configuration. Partial Import can also be used to transfer custom data, counters and timers from one controller to another. If the file contains configuration of more than one system, each system will be imported one at a time until done.

Importing may not always be fully successful. Configuration values that point to another value, such as 'source' values that point to voltage, current or temperature, may not exist or may be ambiguous. If this is the case, the value is ignored and an entry is made in the event log. It is then necessary to remap the source field to a valid value.



Notice: *Some configuration cannot be exported:*

- *Controller description and location information (this is unique to each controller)*
- *IP configuration (to avoid loss of Ethernet connectivity)*
- *Web server port configuration (to avoid loss of Ethernet connectivity)*
- *Line power channels (unique to line power modules)*
- *Power module (power modules are unique to a system)*
- *Users (to maintain password security)*
- *Server passwords (for example, email server password; to maintain password security)*

To import settings:

1. From the main dashboard go to, **Controller > Files & Upgrades > Configuration & Software Backup**.
2. Select the **Import** button, select a file to import and select the **Upload** button.
3. If the configuration cannot be imported without ambiguity, there will be a drop-down list on **Select System** page to select the destination system or ADIO module. This only happens if trying to do a partial import. Select the destination system and select **Next**.
4. A page displaying an **Settings to Import** is shown. Review the summary and select **Next** to import. If the summary looks incorrect, you can close the wizard and try **Import** again to select another file.
5. Perform **Replace ADIO** if required. When this operation is done, the controller gives special attention to the status of relays mapped to a disconnect. If, as a result of the replace operation, a disconnect relay will be shared with an alarm relay or if the state of a disconnect relay will change because of a change to the relay polarity, the replace will fail and an entry made in the event log identifying the alarm relay was causing the failure.

20.5.5.1. Import a system

It is common to create a system on the controller that has been already configured on a different controller. This can be done by first exporting a configuration file from the already configured controller, then importing it. When exporting, choose the appropriate export method, either clone or copy, as previously described.

To import a system in a configuration file:

1. Go to **Controller > Files & Upgrades > Configuration & Software Backup**.
2. Select the **Import** button to launch the import wizard.
3. Use **Select File** to browse to the configuration file on your local computer (for example, `exportconfig.xml`).
4. Select **Upload** to upload the file to the controller.
5. Review the **Import Summary** page. This shows a summary of what you are about to import. If it is not correct, close the wizard and start over to select a different configuration file.
6. Select **Next**, and then wait for the import to complete. If the import fails or encounters an error an error message is displayed.
7. Perform **Replace ADIO**, if necessary. If the imported system referenced one or more ADIO modules the import included these ADIO modules, and they now show up as **Comms Lost**. You should replace these **Comms Lost** ADIO modules with existing ADIO modules of the same type via the **Modules** menu.

The system has been imported and configured to use the existing ADIO module.

20.5.6. Configuration restore points

The Configuration Restore Point feature will automatically capture the configuration of the controller daily (if anything has changed), providing automatic backups that can be used in situations where changes may have been made by mistake. This feature also enables you to:

- Create a configuration restore point manually. This can be useful to keep a backup before a big configuration change, or to create a known good configuration that can be restored to at a later point.
- Restore to a configuration restore point. This will restore the configuration of the controller to the configuration it had when the configuration restore point was created.

Configuration restore points can be found by going to **Controller > Files & Upgrades > Configuration & Software Backup**. On this page there are two tables related to configuration restore points:

- **Configuration Restore Point Information:** This table provides general information about how the feature works, such as how many restore points will be kept, the frequency they are created, and which restore points will be deleted if the maximum is reached.
- **Configuration Restore Points:** This table provides information about the actual restore points. Each row represents a restore point, and provides information about when it was created, a user-defined description, and if the specific restore point can be deleted or not.



Notice: *These restore points only keep a copy of the configuration of the controller, not the software application. It is possible that restoring to a restore point from an older software version could cause unexpected behavior. Please read the warnings and help in the wizard to ensure the restore will restore what is expected.*

20.5.6.1. Create configuration restore points

Configuration restore points will be created daily (if any configuration changes have been made). It is also possible to manually create a restore point. To manually create a configuration restore point:

1. Go to **Controller > Files & Upgrades > Configuration & Software Backup**.
2. On the **Configuration Restore Points** table, select **Create Configuration Restore Point**.
3. Read the **Preview**, then select **Next**.
4. Enter in a **Description** and specify the **Deletion Policy** for this restore point, then select **Next**.



Notice: *A maximum of five restore points can be marked as **Never Delete**. This should be used to ensure important restore points will never get deleted when daily restore points are created.*

5. Review the data you entered in, then select **Next**.

A new configuration restore point has now been created, and can be used to restore a configuration of the controller if necessary.

20.5.6.2. Restore to a configuration restore point

If a configuration was changed by mistake, it is possible to undo those changes by restoring to a configuration restore point. To restore to a configuration restore point:

1. Go to **Controller > Files & Upgrades > Configuration & Software Backup**.
2. In the **Configuration Restore Points** table, select the details arrow beside the restore point you wish to restore to.
3. On the details page of the restore point, select **Restore Configuration To This Point**.
4. There will be three tables shown: **Items To Be Added**, **Items To Be Removed**, and **Configuration Changes**. These tables explain the changes you will see if the controller configuration is restored to this restore point. After reading through and ensuring these changes are desired, select **Next**.



Notice: Before the configuration is restored, a new restore point will be created. This will allow you to restore back to the current configuration if necessary.

5. If restoring will cause anything to be removed from the controller, another step will appear warning that these items will be removed. To proceed with the restore, enter **confirm** in the text box, then select **Next**.

After a short period of time, the wizard will display that the configuration has been restored.

20.5.7. Export diagnostic information



Important: To facilitate any support request, export a diagnostic information package before contacting support.

Exporting a diagnostic information package helps the support team provide assistance with any issues you may experience. This information package is an archive that contains the following:

- Controller clone
- Device Log
- Event Log
- Battery Log
- Daily statistics for all Performance Logs
- Datalogs

Additionally, if any T2S modules for the AMPS HP2 inverter system are acquired, an additional step will be available in the **Export Diagnostic Information** wizard to include their logs and configuration files in this package.

20.5.7.1. Export a diagnostic information package

This package can be obtained in the following ways, via the LCD or via the web interface.

1. From the dashboard of the LCD, go to **Shortcuts > Export Diagnostic Information** to launch a wizard that will generate save the package to a USB drive.
2. From the web interface, select the **Accounts > Export Diagnostic Information** on the top bar to launch a wizard that will generate the file and let you download the file to your computer. This wizard is also available from **Controller > About > General**.

20.5.8. License key

Some features and functions on the controller require a separate license key. Most controllers have the correct license keys installed at the factory. If a controller is purchased as a spare or is being re-purposed from a different type of system, it may be necessary to update the license key.

License key operations available on both the web interface and LCD are as follows:

- **Import** and **Export** of license key files
- **Enable** and **Disable** a temporary license

20.5.8.1. Export a license key file

To update the license key on a controller, the first step is to export the current license key, and then send it to the company from which your system was purchased.

To export a license key:

1. From the main dashboard, go to **Controller > Files & Upgrades > Licenses**.
2. Select the **Export License Key File** button.

From the web interface, this downloads a licenses.txt file to your downloads folder. From the LCD, this saves a licenses.txt file on your USB drive.

20.5.8.2. Import a license key file

Once you have an updated license key file you can import it into your system and enable the new license.

To import a license key:

1. From the main dashboard, go to **Controller > Files & Upgrades > Licenses**.
2. Select the **Import License Key File** button. From the web, you are prompted to locate the file (for example, licenses.txt) and upload to the controller. From the LCD, select from the *.txt files on your USB drive.

There are three possible results depending on the license key file imported.

The license key file is valid and raises the level of at least one license key	<p>Three things should happen:</p> <ol style="list-style-type: none"> 1. The value or level of at least one license key in the Licenses table should change. You can check the event log to confirm which values changed. 2. If a temporary license was enabled, that temporary license is now disabled. This prevents the temporary license from expiring after a permanent license key has been uploaded. 3. If there were licensing alarms, they should have cleared.
The license key file is valid but does not raise the level of any license keys	No errors will be generated but no license key values will be changed either. It is not possible to downgrade a license key. Any license keys that are less than or equal to the current license key will be ignored.
The license key file is not valid, is corrupt or is for a different controller	An error message states that the licensing information is not valid for this controller and the file will be ignored. Look at the text of the licensing file, and ensure that the first line matches your controller ID.

20.5.8.3. Temporary license

It is possible to enable a temporary license that will enable all licenses on the system for one month in total. This is intended to be used in situations where it is not possible or convenient to wait for a permanent license to be sent. You can enable the temporary license, get everything up and running, and then request the permanent license at some later time. The time remaining on the Temporary License will count down from 31 days and it can not be easily reset.

To enable/disable a temporary license:

1. From the main dashboard, go to **Controller > Files & Upgrades > Licenses**.
2. Select the **Enable Temporary License** button.

As long as the time remaining is not zero, the **Temporary License Status** value changes to enabled.

The time remaining counts down the number of days remaining.

3. Select the **Disable Temporary License** button.

The **Temporary License Status** value changes to disabled.

The time remaining shows the number of days remaining.

20.5.9. Upload the software manual

The controller software manual can be uploaded to the controller so it is directly accessible via the web interface. The controller can only contain one version of the software manual at a time.

To upload the user manual:

1. Go to www.alpha.com, and then download the HTML version of the software manual for controller upload.
2. Go to **Controller > Files & Upgrades > Software Manual**.
3. Select **Upload Software Manual**, and then select a file to import.
4. Select **Upload**. It takes several minutes for the file to upload and install. When the upload is complete, a notification is displayed.
5. Select **Account and Shortcuts** dropdown menu on the top right-side of the browser window to confirm that the file is installed.
6. Select the **Software Manual** entry at the top of the list. A new browser tab should open with the software manual. If not, try refreshing the browser using F5 on your keyboard.

A navigation and search pane opens on the left-side of the browser window. Use this to search for content. If required, it is also possible to print pages from this pane.

20.5.10. Export inventory file

A common system maintenance activity is to gather, record and archive a set of data about the controller and systems. This can be a tedious process depending on the amount of data required. To facilitate this the controller provides a set of data, both live status data and configuration, as a downloadable file. This file contains most of the information that is viewable from the LCD and web interface and serves as a snapshot of the present state of the controller.

To download this file:

1. If using a controller with the LCD or OLED display, insert a USB drive.
2. Go to the menu location to find the download button:
 - a. On the LCD, go to **Maintenance** and scroll down to the **Export Inventory to CSV** button and select it.
 - b. On the web interface, go to **Controller > Inventory** and select the **Export Inventory to CSV** button in the **Inventory** table.
 - c. On the in-shelf controller with the OLED display, select the **Menu** button and scroll down to **Explnv** and press the **Menu** button again.
3. Select the **Export** button to initiate the download.

Once started, the file is downloaded to the USB drive or PC depending on where the export was initiated from. If initiated from the LCD or OLED display it is downloaded to the USB drive. If initiated from the web interface it is downloaded to the PC. Depending on the amount of data to download, it may take several minutes to complete.

This file can now be opened in a spreadsheet program for analysis.



Notice: Sensitive data related to users and user permissions, passwords, and licensing is not included in the exported file.

20.5.11. Backup and restore

A full backup of the controller can be created using the backup feature. The created backup can then be used to restore to a known application version and configuration. The **Backup** command will make a copy of the application software and configuration information for that version of application in a single backup file. This includes controller-specific information such as IP addresses, usernames, and passwords.

The **Restore** command provides the ability to take an existing backup file and restore the contents of that file into a controller. All existing application and configuration information will be deleted and replaced by the contents of the backup file.

The **Backup and Restore** feature is intended to be used to recover from severe errors. If a controller was damaged and required a replacement, then a backup file can be used to restore a new controller to the same application version and configuration as the previous controller.

A **Backup** command can be initiated via the web interface or LCD while a **Restore** command can only be initiated via the LCD.

20.5.11.1. Export controller backup via web interface

To create a controller backup on the web interface:

1. Go to **Controller > Files & Upgrades > Configuration & Software Backup > Backup Filetable**.
2. In the **Backup File** table, find the **Export Controller Backup** button.
3. Select the **Export Controller Backup** button.
4. After about a minute, the **Backup File** is created and downloaded to local PC.

20.5.11.2. Export controller backup via LCD

To create a controller backup on the LCD:

1. Insert a USB drive into the controller USB port.
2. Go to the **Shortcuts** menu and select the **Backup** shortcut.
3. After about a minute, the **Backup** is created and added to the USB drive.

20.5.11.3. Export controller backup via scheduled action

A **Scheduled Action** can be configured to automatically backup the controller to a USB drive at configurable intervals.

To automatically backup a controller at configurable intervals using a USB drive:

1. Insert a USB drive into the controller USB port.
2. On the web interface or LCD, go to **Controller > Programmability > Scheduler**.
3. Select **Create Scheduled Action** to start the Create Scheduled Action wizard.
4. In the wizard, configure the Schedule Type and Schedule Details. In the **Action** section, select the **Backup Controller to USB Drive** action.
5. Finish the wizard and the action will be displayed in the **Scheduled Actions** table. The action will run at the configured time interval.

20.5.11.4. Restore a controller using a backup file via LCD

To restore a controller using the LCD:

1. Insert a USB drive that has a previously created **Backup** file into the controller USB port.
2. Go to **Shortcuts > Restore**.
3. Select the displayed **Backup** file from the USB.
4. Select the **Execute** button to start the restore.
5. After about a minute, the controller restores to the backup file contents.

20.6. User account maintenance

20.6.1. Set up users and permissions



Notice: *These features are only available to those with Administrator or Account Manager privileges.*

By default, the controller has seven user accounts: one administrator, one account manager, and five operators. The Name field in these accounts is not editable. User accounts cannot be added or deleted, but they can be enabled or disabled.

Within the **Users and Security** menu you can use the **User Roles** dropdown menu to configure what privileges each user has when accessing the system or changing passwords.

This section of the document covers the following:

- Editing user permissions
- Enabling new users
- Disabling users

20.6.2. Edit user permissions

These features are only available to those with Administrator or Account Manager privileges.

To edit user permissions:

1. Go to **Controller > Users & Security > Users**.
2. In the **User** table, select the **GO TO** button on the line of user whose access must be changed.
3. On the right-side of the User Role line, select the **EDIT** button.
4. From the dropdown menu, set the **User Role** and select **Save**.

20.6.3. Enable new users

Within the **User & Security** menu you can enable, edit, and disable users. Only users with Administrator or Account Manager privileges can enable users. Within the **User Roles** drop-down menu you can configure the privileges each user has as well as create passwords. The different levels of user permissions are as follows:

- **Administrator:** Can modify all configurations, perform any actions with the exception of factory information.
- **Account Manager:** Can only create and modify user accounts.
- **Operator:** Can modify all configurations, can change their own password.
- **Restricted Operator:** Can modify configuration values, but cannot add or remove systems or inventory, can change their own password.
- **Guest:** Can read any field, but can not configure any settings.

To enable a user:

1. Go to **Controller > Users & Security > Users**.
2. From the **User** table, select the **GO TO** button on the operator1 line.
3. Optional: Edit the **Description** and select **Save**.
4. Optional: Edit the **Alias** and select **Save**.

The alias field allows login names that a user is more familiar with. For example, if you set the *operator1* alias to *TL1*, you can login to the operator1 account using the *TL1* user name.

5. Set the **User Role** (permissions) and select **Save**.
6. From the operator1 table, select **Change User Password** to set the password and select **Save**.
7. Login using the updated password or permissions.

20.6.4. Disable users

These features are only available to those with Administrator or Account Manager privileges. User accounts are not actually deleted, they are edited to remove a user's access to the system.

To disable users:

1. Go to **Controller > Users & Security > Users**.
2. From the **User** table, select the **GO TO** button on the line of user whose access must be changed.

3. On the right-side of the **User Role** line, select the **EDIT** button.
4. From the dropdown menu, set the User Role to **No Access**.
5. Select **Save**.

20.6.5. Changing the default password from the LCD

This section describes how to change user passwords from the LCD.

You must be logged in to the controller to change passwords.

To change the default password:

1. From the main Dashboard, select the **Menu** button.
2. Select **Controller** to highlight it, and then select the arrow on the right-side.
3. Select to highlight **Configure Controller**, and then select the arrow on the right-side.
4. Swipe with an upward motion on the touchscreen to scroll down to **Users and Security**, and select to highlight.
5. Select the arrow on the right-side, and then select **admin**.
6. Select **Change User Password**.
7. Select the **Execute** button to modify the default, and then select the checkmark to save your changes.

20.6.6. Changing the default password from the web interface

This section describes how to change the default password via the web interface.

To change the default password via the web interface:

1. From the main dashboard, go to **Controller > Users & Security > Users**.
2. From the **admin** line in the Users table, select the **GO TO** button on the right-side of the table.
3. From the admin table, select the **Change User Password** button.
4. Enter your existing password, a new password then again confirm the password. Select **Save** to save the password change.

20.6.7. User account password requirements

When changing a user account password, the following requirements apply:

- **Minimum password length:** 4 characters
- **Maximum password length:** 60 characters
- Any characters (including those from non-latin alphabets) are allowed
- There are no complexity requirements, such as requiring numbers or symbols
- Passwords do not expire



Notice: *The use of some non-latin characters may reduce the maximum allowable password length.*

20.6.8. Machine user

In addition to the regular users mentioned in a previous section, there is also a "machine" user. This user is not shown on the **Users** page. This user is not used by a person, but rather is used to allow external software to interact with the controller. By default, the "machine" user is disabled. This can be seen by looking at the **Machine Account Status** table on the **Users** page. The "machine" user will only ever become enabled if a user provides external software authorization to perform operations on this controller. This authorization process is done in the external software, and uses the same authentication mechanism as normal logins via the web interface.

When external software performs operations on a controller, event log entries can be seen showing the "machine" user logging in, as well as which external software is performing the operations, and who initiated them.

When the "machine" user is enabled, that authorization can be revoked by:

1. Go to **Controller > Users & Security > Users**
2. In the **Machine Account Status** table, select **Disable Machine Account**, and select **Yes**
The external software will no longer be able to use the "machine" user to perform operations on this controller.

20.6.9. Remote configuration lockout

The **Remote Configuration Lockout** feature allows for a complete lockout of configuration changes from the web interface. When this feature is active, no user, regardless of permission level, will be able to change or modify the configuration via the web interface. Configuration changes will still be possible via the LCD.

To enable this feature:

1. On the LCD, go to **Maintenance > Remote Configuration Lockout**.
2. Select the **EDIT** button beside **Remove Configuration Lockout**, change the value to **Disabled** (logging in if required), then save.
3. Select the **EDIT** button beside **Lockout Override Time**, enter in the desired time to override the lockout (more on the override in the following sections), then save.

After the **Remote Configuration Lockout** feature is enabled, no configuration changes will be allowed from the web interface.

20.6.9.1. Overriding the remote configuration lockout from the LCD

After the **Remote Configuration Lockout** feature has been enabled, it is possible to override the lockout for a user-specified amount of time. This will allow a technician on-site to override the lockout temporarily to allow for a user off-site to perform some configuration via the web interface.

To override the remote configuration lockout from the LCD:

1. On the LCD, go to **Maintenance > Remote Configuration Lockout**.
2. Select **Override Remote Configuration Lockout**, then select **Execute**.

The configuration lockout will be overridden for the amount of time that has been configured. The time remaining in the override can be seen via **Lockout Override Time Remaining**.

20.6.9.2. Overriding the remote configuration lockout from the OLED display

To override the remote configuration lockout from the OLED display:

1. On the OLED display, go to the menu by selecting the **Select** button.
2. Scroll down and select the **RemCfg** button.

You will be shown a **Lockout Overridden success** confirmation message, and the configuration lockout will be overridden for the amount of time that has been configured.

20.7. Remote authentication

The controller is configured with local user accounts by default, where login credentials are verified against encrypted data on the controller. Remote authentication provides an additional ability to verify login credentials from a remote server. This can be an advantage from a network security standpoint, as login credentials can be updated from one central server rather than being updated individually on each controller. Enabling Remote authentication has no effect on the already configured default user accounts stored locally on the controller.

The controller supports credential caching. In the case that the controller is not able to contact the specified remote server, the controller will verify the user's credentials against the last ten authenticated credentials encrypted and stored locally on the device.

The controller can support remote authentication through either the RADIUS or TACACS+ protocol..



Notice: Login access to the default user accounts are unaffected when a remote authentication server is inaccessible.



Notice: Remote Authentication passwords are limited to 32 characters. Shared Secrets and Secret Keys are limited to 52 characters. The User Roles Configuration fields are case-sensitive when matched against the values stored on the remote server.

20.7.1. RADIUS authentication

Remote Authentication Dial-In User Service (RADIUS) is a client/server protocol and software that enables clients to communicate with a central server to authenticate and authorize their access to the requested system or service. This section of the manual describes RADIUS Authentication, its features, and how to setup the controller as a RADIUS client.



Notice: See your RADIUS server documentation for information about setting up the RADIUS server.

20.7.1.1. RADIUS authentication

The Cordex® CXC HP controller can be configured to use a RADIUS server to remotely authenticate users. In this case, the controller is acting as a RADIUS client. A RADIUS server, such as FreeRADIUS, must be configured separately for remote authentication to work correctly.



Notice: See your RADIUS server documentation for information about setting up the RADIUS server.

The following are features for using RADIUS authentication.

- **Encryption Protocol:** Provides encrypted Password Authentication Protocol (PAP) or Challenge-Handshake Authentication Protocol (CHAP).
- **Encrypted RADIUS Shared Secret:** Provides a securely encrypted, shared secret authentication on the RADIUS server.
- **Test RADIUS Server Settings:** Provides an authentication request to test the RADIUS server settings.
- **Network:** Operates on the User Datagram Protocol (UDP).

How RADIUS Authentication Works

When the **Remote Authentication Type** field is set to **RADIUS (TACACS+ is disabled)** on the controller, the user credentials are encrypted, and an authentication request is sent to the RADIUS Server. When the **Remote Authentication Type** field is set to **None (RADIUS and TACACS+ are disabled)**, only local user accounts can login.

By default, the controller expects the RADIUS server to return the user's authentication using **Group Attribute ID 11 (Filter-Id)**. When a RADIUS response is received from the RADIUS server, the value of attribute "Filter-Id" contains a string **Group Attribute Value** that defines the user role. The controller uses the User Role Configuration table to match the string received from the RADIUS server to authenticate the user. If the user's **Group Attribute Value** matches one of the assigned user roles, the matching user privilege is granted. For example, if the received Filter-ID attribute has a value "operator", the user has "Operator User Role". If there are no match, the user is denied access. Upon a successful login, the encrypted user credentials are saved in the controller's cache. This can be used if there is a situation where the RADIUS Server is unavailable.



Notice: The user can pick any attribute supported by RADIUS to return the user role. The important thing is that the attribute ID used must match the attribute used to define the user's role in the RADIUS server's user configuration.

- **Remote Authentication Type:** When set to **RADIUS (TACACS+ is disabled)**, users are allowed to be authenticated by a RADIUS server.
- **RADIUS Authentication Server Address:** The DNS name or the IPv4 / IPv6 address for the RADIUS server.
- **RADIUS Authentication Server Port:** The default port is 1812.
- **RADIUS Timeout:** The time, in seconds, that the controller waits for a response from the RADIUS server.
- **RADIUS Encryption Protocol:** The authentication method used by the controller to encrypt user passwords. This is either Password Authentication Protocol (PAP) or Challenge-Handshake Authentication Protocol (CHAP).
- **RADIUS Server Shared Secret:** The shared secret between the controller and the RADIUS server. Set this value by using the **Set Shared Secret** button. You can clear the configured shared secret by using the **Clear Shared Secret** button.

20.7.2. TACACS+ authentication

Terminal Access Controller Access Control System Plus (TACACS+) is a client/server protocol and software that enables clients to communicate with a central server to authenticate and authorize their access to the requested system or service. This section describes TACACS+ authentication and authorization, its features, and how to setup the controller as a TACACS+ client.



Notice: See your TACACS+ server documents for any detailed information on setting up the TACACS+ server.

20.7.2.1. TACACS+ authentication

The Cordex® CXC HP controller can be configured to use a TACACS+ server to remotely authenticate users. In this case, the controller is acting as a TACACS+ client. A TACACS+ server, such as TACACS.net, must be configured separately for remote authentication to work correctly.

The following are features for using TACACS+ authentication.

- **Encryption Protocol:** Provides encrypted Password Authentication Protocol (PAP), Challenge-Handshake Authentication Protocol (CHAP), or ASCII Authentication.
- **Encrypted TACACS+ Secret Key:** Provides a securely encrypted, secret key which is not sent between the controller and the TACACS+ server. The secret key must be set identically on both the controller and the TACACS+ server.

- **Test TACACS+ Server Settings:** Provides a check to determine if the basic TACACS+ configuration is set correctly. This feature additionally completes a trial authentication request to ensure it can contact the TACACS+ server.
- **Network:** Operates on the Transmission Control Protocol (TCP).



Notice: *The **Test TACACS+ Server Settings** feature cannot determine if the Attribute Name and Group Attribute values are spelled correctly since these are set on the TACACS+ server side.*

How TACACS+ authentication works

When a user logs in when the **Remote Authentication Type** field is set to **TACACS+ (RADIUS is disabled)** on the controller, the controller will begin communication with the TACACS+ server. A packet body containing the user's credentials will first be encrypted and sent to the server; depending on the **TACACS+ Encryption Protocol** selected, there may be multiple messages sent between the controller and the TACACS+ server.

If the TACACS+ sever authenticates the user, the controller will then send a TACACS+ Authorization request. At this point, the TACACS+ server will respond with any Attribute-Value pairs that are set within the server configuration. If any of these pairs match the **Attribute Name** and one of the **Group Attribute Values** of the User Roles Configuration table, the controller will assign the respective user privilege and proceed to log the user in. If there are no matches, the user is denied access. If two or more **Group Attribute Values** are assigned the same value, the controller will assign the first matching user role in the following order: Admin User Role, then Accounts User Role, then Operator User Role, then Restricted Operator User Role, then Guest User Role.

Upon a successful login, the encrypted user credentials are saved in the controller's cache. This can be used if there is a situation where the TACACS+ Server is unavailable.

The following TACACS+ server settings can be configured:

- **Remote Authentication Type:** When set to **TACACS+ (RADIUS is Disabled)**, users are allowed to be authenticated by a TACACS+ server.
- **TACAS+ Authentication Server Address:** The DNS name or the IPv4 / IPv6 address for the TACAS+ server.
- **TACAS+ Authentication Server Port:** The default port is 49.
- **TACAS+ Timeout:** The time, in seconds, that the controller waits for a response from the TACAS+ server.
- **TACAS+ Encryption Protocol:** The authentication method used by the controller to encrypt TACACS+ packet bodies. This is either Password Authentication Protocol (PAP), Challenge-Handshake Authentication Protocol (CHAP), or ASCII authentication.
- **TACACS+ Server Secret Key:** The secret key stored on both the controller and the TACACS+ server. Set this value by using the **Set Shared Secret** button. You can clear the configured shared secret by using the **Clear Shared Secret** button.



Notice: TACACS+ credentials (User Name, Secret Key and Password), the Attribute Name, and Group Attribute Values must contain only printable ASCII characters.

20.8. Flash maintenance

This section of the document covers, **Using Memory Status** to see memory and disk usage, as well as **Performing a Flash Refresh** when necessary.

20.8.1. Memory status

The **Memory Status** page displays various information about flash, including:

- The types of files that are using disk space.
- The total amount of disk space, and the amount remaining.
- The total amount of memory, and the amount of memory being used.
- The number of correctable errors on flash.
- Alarms: There is one alarm, **Disk Almost Full**.

The disk space information can be used to help determine which files are taking up the most space if the controller runs out of disk space. All this information can be accessed by going to **Controller > About > Storage & Memory**.

20.8.2. Flash refresh

Over time, the flash can accumulate correctable errors. These correctable bit errors can be fixed by performing a flash refresh. A flash refresh will happen every 30 days automatically, but it can also be manually triggered.

To start a flash refresh:

1. Go to **Controller > About > Storage & Memory**.
2. In the **Flash Refresh** table, select the **Run Flash Refresh** button to start a flash refresh.



Notice: Flash Refresh is available in OS version 4.70 and later.

20.9. Secure web server

The controller supports secure web access via the Hyper Text Transfer Protocol Secure (HTTPS) protocol using TLS v1.2.

20.9.1. HTTPS and certificate overview

The controller can provide secured Hypertext Transfer Protocol (HTTP) over Transport Layer Security (TLS) HTTPS. HTTPS is provided by using the well-defined industry standard of implementing certificates for secured connections.

 **Notice:** A subject matter expert or IT personnel is required to support private key and certificate management and installation to the controller and any other HTTPS configuration activities. The use of a self-signed certificate is allowed within controller. With first access to the web server, the browser will display a pop-up indicating a self-signed certificate and a “Trust” acknowledgment is required. Self-signed certificates allow you to secure a large number of controllers using a self-managed domain name address for each controller

 **Notice:** Secure connection can only be achieved by the browser if a domain name is used (example, <https://www.alpha.com>). Based on web browser standards, an IP address cannot resolve to a secured connection to the controller.

Two files must be uploaded to enable HTTPS on the controller. The public key, often referred to as the certificate, and the private key, which is a certificate verified by an independent Certificate Authority (CA). Most modern browsers will automatically trust and accept a certificate from a known CA. We recommend that subject matter expert or IT person with HTTPS experience complete this process.

20.9.2. Configure HTTPS

The settings for HTTPS are located under **Controller > Communication > Web Server**.

By default, HTTPS is disabled on the Controller on first start-up.

20.9.2.1. Web server ports

The controller has configurable web server ports on the web interface. The standard HTTP port defaults to port 80 and the standard HTTPS port defaults to port 443. If using a custom port number, it is recommended to use custom port numbers above port 1024.

 **Notice:** A soft restart of the controller is required after all configurations are made when changing HTTP server port values.

20.9.2.2. Upload a certificate and key

HTTPS requires a valid certificate and a private key file to be uploaded to the controller. Using an RSA key is recommended as it is the universally accepted key type by common web browsers. The controller is compatible with certificates following the X.509 standard.

 **Notice:** A subject matter expert or IT personnel are required to support private key and certificate management as well as installation to the controller.

The controller requires a single certificate file, which contains the specific certificate issued to the controller, along with the intermediate certificate immediately following. A copy-and-paste process can consolidate multiple certificates for this purpose. An example certificate file with two embedded certificates shown here.

Figure 20-4 Example certificate

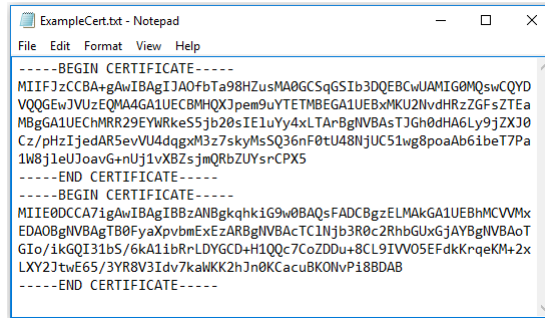

A completed installation of the private key and certificate file result in a Valid response.

Figure 20-5 Valid certificate

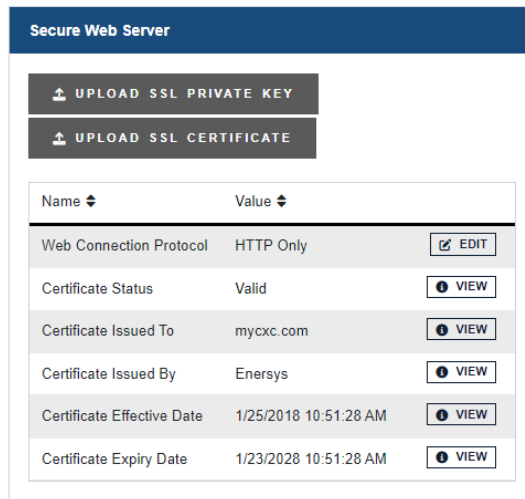

An incomplete installation will result in an Invalid response. An incomplete installation (if only the key or the certificate is installed), will result in an incomplete response.

If both the key and certificate have been uploaded, but there is a problem with either one of these the files, the status will also be Invalid.

The controller ensures secured storage of the private key to prevent unauthorized access to the file.

20.9.2.3. Enable HTTPS

Once a valid SSL key and certificate have been uploaded, HTTPS can be enabled by editing the field called **Web Connection Protocol**. There are three choices available:

- **HTTP Only:** This is the default, the web server will only listen on the regular HTTP port.
- **Both HTTP and HTTPS:** This means that the web server will listen on both the regular HTTP port (port 80) and the HTTPS port (port 443). Users can connect using either. If you connect via http:// this is not a secure access protocol.
- **HTTPS Only:** This is the recommended setting for the most security. The web server will only listen and respond to requests on this port. Users **MUST** access the web server via a URL starting with https:// or they will be unable to connect.

After any change to the **Web Connection Protocol** setting, the controller must be restarted before the changes take effect. The **Restart Required** alarm will activate as a reminder.

 **Important:** *Enabling HTTPS means that every packet passed between the client, and the server is encrypted and then decrypted again on the other side. This slows the browser considerably. How much, depends on which browser and which type of encryption cipher is negotiated between client and server.*

20.10. VLAN support

If the controller's operating system supports VLAN tagging (OS version 4.30 and later), the controller can operate on VLAN tagged networks.

To configure the VLAN feature, go to **Controller > Communication > Ethernet**, and go to **VLAN Support** table.

If the operating system does not support VLAN, the configuration fields are not editable.

After making the changes described below, restart the controller to have the changes take effect. A **Restart Required** alarm activates as a reminder.

1. Set **VLAN Support** to **Enabled**.
2. Choose which interface to enable VLAN on: the rear Ethernet port, or the front Ethernet port.
3. Choose a VLAN tag number.
4. Restart the controller. This may take a few minutes. You will be automatically re-directed to the login page once the controller is ready.

20.11. Test relays

A common maintenance activity is to periodically verify that controller relays actuate and successfully communicate controller alarms to remote monitoring equipment. Relays can be tested from the ADIO details on the **Modules** menu or the **Maintenance** menu on the LCD.

To test relays on the LCD:

1. Go to the **Maintenance** menu from the LCD dashboard.
2. Scroll down to the **Test Relays** row.

3. Select the relay symbol on the right hand side. A list of all relays is shown.
4. Select a relay to and select the arrow on the right hand side. A **Test Relay** action is shown at the top of the screen with the relay status underneath it.
5. Select the **Test Relay** action and select the arrow on the right hand side. If you are prompted to login, select the **Login** button and enter user credentials.
6. Select the **Execute** button to start the test. The relay will change state for one minute before reverting.
7. To stop the test or to restart the test, select the back arrow.

21. Maintaining modules

When maintaining your modules always check for known issues within the readme file that ships with your software. This section of the manual covers the following:

- ADIO peripheral configuration and maintenance
- Module firmware upgrades

21.1. ADIO peripheral maintenance

To locate connected ADIO devices go to **Modules**, in the **CAN Modules** table find the device you want to locate and then select **Locate** button. The LEDs on the selected ADIO module will flash.

21.1.1. Configure an ADIO peripheral

To configure an ADIO peripheral:

1. To view status of inputs and outputs go to **Modules** and select an ADIO.
2. To configure a digital input, select the **GO TO** button for the selected digital input. Active when can be configured as **Energized** or **Not Energized**.
3. To configure a relay, select the **GO TO** Button for the selected relay. Normal position of the relay can be set to **Energized** or **Not Energized**. A relay can also be set to de-energize if communication is lost between the controller and the ADIO module. To do this, set the **Comms Lost Action** to **De-Energize on Comms Lost**. This feature was added in controller software version 6.10 and requires up-to date firmware on the ADIO module. This feature cannot be used on relays that are used for control functions, like disconnects.
4. To change the calibration, select the **GO TO** button for the selected analog input. You must be logged in as an Administrator to launch the **Factory Calibration** wizard.
5. The **Comms Lost Timeout** should normally left at the default value. It is only used in advanced configurations with a redundant controller and ADIO module.

21.1.2. Replace an ADIO peripheral

ADIO modules have a lot of configuration and often have many links to things such as the system voltage or alarm relays. Because so much configuration is tied to an ADIO module, there is a command for replacing the ADIO module that retains all of its configuration.

To replace an ADIO peripheral:

1. Go to **Modules**.
2. Use the **Locate** button to find the two ADIO modules, the old one (to be replaced) and the new one. It may be useful to note the two serial numbers, in the identity column, if there are multiple ADIO modules in the list.

The Locate button will only work on ADIO modules that have “Normal” Communication status.

3. Select the **Replace ADIO** button and the wizard guides you through the process.
4. Select the **Finish** button to accept the change. The resulting table should have the new ADIO module in it along with all of the mappings and configuration from the old ADIO module.
5. Verify the ADIO module.

Verify that the new ADIO module is reading the inputs correctly, and that any inventory items are reporting the correct values. For example, check that the load or battery current readings are correct.

21.1.3. Calibrate analog inputs



Notice: Calibration is considered an expert user task. Users must be logged in with Administrator privileges to perform this calibration.

This section covers the calibration of analog inputs on the ADIO module including voltage, current, current transducer and temperature. This calibration method is only supported for the Cordex® HP family of ADIO smart peripherals. Older ADIO modules such as the shunt multiplexer (MUX) can be monitored via the controller but cannot be calibrated.

The factory calibration of Cordex® CXC HP ADIO peripherals is very precise. It should not be a normal practice to recalibrate them in the field. If you need to apply a deliberate mis-calibration, we recommend the use of custom data fields to document and perform this type of conversion.

If the factory calibration values need to be recalculated, there are three calibration modes:

- Slope/offset calibration
- Single-point calibration
- Two-point calibration

Table 21-1 ADIO input calibration modes

Mode	Description
Slope/Offset Calibration	Use Slope/Offset Calibration mode to do all of the measurements and calculations manually and then enter results into the appropriate fields. If an input has been accidentally mis-calibrated, use this mode to reset the Calibration Slope to one, and the Calibration Offset to zero, which provides reasonable values to start with.
Single-Point Calibration	Use Single-Point Calibration to adjust the Calibration Offset based on a single measured value. For voltage, current and DCCT inputs, use a Single-Point Calibration to confirm that zero volts (or millivolts) is reading as exactly zero volts on the ADIO module. For a temperature input, you may want to confirm that 3.0V is being read accurately.

Table 21-1 ADIO input calibration modes (continued)

Mode	Description
	A Single-Point Calibration only changes the Calibration Offset value. It never changes the Calibration Slope value.
Two-Point Calibration	Use the Two-Point Calibration to update Calibration Offset and Calibration Slope based on two measured values (a low-point and a high-point). For a Two-Point Calibration , connect the ADIO module input to a stable voltage source that accurately generate values across the full range of the input sensor. Do not use a noisy or fluctuating input for calibration. Also, do not try to generate an accurate millivolt signal on a device not intended to work in such a low range.

You can perform calibration from the LCD as well. You must login with administrator privileges to see the **Factory Calibration** commands in the LCD.

21.1.3.1. Voltage input calibration



Notice: Calibration is considered an expert user task. Users must be logged in with Administrator privileges to perform this calibration.

To calibrate an input correctly, you need hardware to generate and measure the input signal accurately.

This topic covers how to do a **Single-Point Calibration**. If you need to do a **Slope/Offset Calibration** or a **Two-Point Calibration**, a factory calibration document should be written showing, step-by-step, how both the hardware and the software need to be used to perform an accurate calibration.

To perform a single-point calibration on a voltage input:

1. Go to **Modules**, in the **CAN Modules** table select an **ADIO** and select the **GO TO** button to view the **Voltage Inputs** table.
2. Select the **GO TO** button of a **Voltage Input** to view its individual menu.
3. Select the **Factory Calibration** button to launch the Wizard.
4. At the **Select Type of Calibration** step, select **Single-Point Calibration**.
5. With a digital voltmeter, measure the voltage across the input.
6. At the **Single-Point Calibration** step, enter the reading on the voltmeter into the **Measured Value** field.
7. Select **Next** to go to **Apply Calibration**. The wizard displays the old slope and offset and the new slope and offset. Before accepting these values, ensure that the slope is very close to 1.0 and the offset is no more than a few volts from 0.0.
8. Select **Next** to send the new offset to the ADIO module.
9. Verify that the newly **Calibrated Value** matches the digital voltmeter reading. Select **Done** to close the Wizard.

21.1.3.2. Shunt input calibration



Notice: Calibration is considered an expert user task. Users must be logged in with Administrator privileges to perform this calibration.

To calibrate an input correctly, you need hardware to generate and measure the input signal accurately.

This topic covers how to do a **Single-Point Calibration**. If you need to do a **Slope/Offset Calibration** or a **Two-Point Calibration**, a factory calibration document should be written showing, step-by-step, how both the hardware and the software need to be used to perform an accurate calibration.

To perform a single-point calibration on a shunt input:

1. Go to **Modules**, in the **CAN Modules** table select an **ADIO** and select the **GO TO** button to view the **Shunt Inputs** table.
2. Select the **GO TO** button of a **Shunt Input** to view its individual menu.
3. Select the **Factory Calibration** button to launch the wizard.
4. At the **Select Type of Calibration** step, select **Single-Point Calibration**.
5. With a digital voltmeter, measure the voltage across the input.
6. At the **Single-Point Calibration** step, enter the reading on the voltmeter into the **Measured Value** field.
7. Select **Next** to go to **Apply Calibration**. The wizard displays the old slope and offset and the new slope and offset. Before accepting these values, ensure that the slope is very close to 1.0 and the offset is no more than a few volts from 0.0.
8. Select **Next** to send the new offset to the ADIO module.
9. Verify that the newly **Calibrated Value** matches the digital voltmeter reading. Select **Done** to close the wizard.

21.1.3.3. Current transducer (CT) input calibration



Notice: Calibration is considered an expert user task. Users must be logged in with Administrator privileges to perform this calibration.

To calibrate an input correctly, you need hardware to generate and measure the input signal accurately.

This topic covers how to do a **Single-Point Calibration**. If you need to do a **Slope/Offset Calibration** or a **Two-Point Calibration**, a factory calibration document should be written showing, step-by-step, how both the hardware and the software need to be used to perform an accurate calibration.

To perform a single-point calibration on a current transducer input:

1. Go to **Modules**, in the **CAN Modules** table select an **ADIO** and select the **GO TO** button to view the **Current Transducer (CT) Inputs** table.
2. Select the **GO TO** button of a **Current Transducer (CT) Input** to view its individual menu.

3. Select the **Factory Calibration** command to launch the wizard.
4. At the **Select Type of Calibration** step, select **Single-Point Calibration**.
5. With a digital voltmeter, measure the voltage across the input.
6. At the **Single-Point Calibration** step, enter the reading on the voltmeter into the **Measured Value** field.
7. Select **Next** to go to **Apply Calibration**. The wizard displays the old slope and offset and the new slope and offset. Before accepting these values, ensure that the slope is very close to 1.0 and the offset is no more than a few volts from 0.0.
8. Select **Next** to send the new offset to the ADIO module.
9. Verify that the newly **Calibrated Value** matches the digital voltmeter reading. Select **Done** to exit the wizard.

21.1.3.4. Temperature input calibration



Notice: Calibration is considered an expert user task. Users must be logged in with Administrator privileges to perform this calibration.

To calibrate an input correctly, you need hardware to generate and measure the input signal accurately.

This topic covers how to do a **Single-Point Calibration**. If you need to do a **Slope/Offset Calibration** or a **Two-Point Calibration**, a factory calibration document should be written showing, step-by-step, how both the hardware and the software need to be used to perform an accurate calibration.

To perform a single-point calibration on a temperature input:

1. Go to **Modules** , in the **CAN Modules** table select an **ADIO** and select the **GO TO** button to view the **Temperature Inputs** table.
2. Select the **GO TO** button of a **Temperature Input** to view its individual menu.
3. Select the **Factory Calibration** button to launch the wizard.
4. At the **Select Type of Calibration** step, select **Single-Point Calibration**.
5. With a digital voltmeter, measure the voltage across the input.
6. At the **Single-Point Calibration** step, enter the reading on the voltmeter into the **Measured Value** field.
7. Select **Next** to go to **Apply Calibration**. The wizard displays the old slope and offset and the new slope and offset. Before accepting these values, ensure that the slope is very close to 1.0 and the offset is no more than a few volts from 0.0.
8. Select **Next** to send the new offset to the ADIO module.
9. Verify that the new **Calibrated Value** matches the digital voltmeter reading. Select **Done** to exit the wizard.

21.1.4. Calibrate shunts, current transducers, and temperature probes

This section covers the calibration of shunts, current transducers, and temperature probes that are connected to ADIO module inputs.

21.1.4.1. Shunt calibration

 **Notice:** Calibration is considered an expert user task.

To calibrate a shunt correctly, you need hardware to generate and measure the input signal accurately.

This topic covers how to do a **Single-Point Calibration**. If you need to do a **Slope/Offset Calibration** or a **Two-Point Calibration**, a factory calibration document should be written showing, step-by-step, how both the hardware and the software need to be used to perform an accurate calibration.

A shunt **Current** reading is calculated as follows:

$$\text{Current (A)} = \left(\frac{\text{ADIO Current Input Reading (mV)}}{\text{Range in Millivolts (mV)}} \times \text{Range in Amps (A)} \right) + \text{Offset (A)}$$

To perform a single-point calibration on a shunt:

1. Go to **Systems > DC System > Inventory > Shunts** and select the **GO TO** button to select one of the available shunts.
2. Set the **Offset** to zero.
3. Measure the actual current flowing in amps. It may be easiest to do this measurement at 0.0 amps.
4. Record the measured value: _____ A.
5. Subtract the displayed value: _____ A, from the web interface.
6. Calculate the new offset: _____ A. Offset = Measured Value - Displayed Value.
7. Select the **EDIT** button of the **Offset** field. Enter the new offset in amps and select **Save**.
8. Verify that the **Offset** field was updated, and that the new displayed value matches the measured value.

21.1.4.2. Current transducer calibration

 **Notice:** Calibration is considered an expert user task.

To calibrate a current transducer correctly, you need hardware to generate and measure the input signal accurately.

This topic covers how to do a **Single-Point Calibration**. If you need to do a **Slope/Offset Calibration** or a **Two-Point Calibration**, a factory calibration document should be written showing, step-by-step, how both the hardware and the software need to be used to perform an accurate calibration.

A current transducer **Current** reading is calculated as follows:

$$\text{Current (A)} = \left(\frac{\text{ADIO CT Input Reading (V)}}{\text{CT Range in Volts (V)}} \times \text{CT Range in Amps (A)} \right) + \text{CT Offset (A)}$$

To perform a single-point calibration on a current transducer:

1. Go to **Systems > Inventory > Current Transducers** and select one of the available current transducers by selecting the **GO TO** button.
2. Set the **Offset** to zero.
3. Measure the actual current flowing in amps. It may be easiest to do this measurement at 0.0 amps.
4. Record the measured value: _____ A.
5. Subtract the displayed value: _____ A, from the web interface.
6. Calculate the new offset: _____ A. Offset = Measured Value - Displayed Value
7. Select the **EDIT** button of the **Offset** field. Enter the new offset in amps and select **Save**.
8. Verify that the **Offset** field was updated, and that the new displayed value matches the measured value.

21.1.4.3. Temperature probe calibration



Notice: Calibration is considered an expert user task.

To calibrate a temperature probe correctly, you need hardware to generate and measure the input signal accurately.

This topic covers how to do a **Single-Point Calibration**. If you need to do a **Slope/Offset Calibration** or a **Two-Point Calibration**, a factory calibration document should be written showing, step-by-step, how both the hardware and the software need to be used to perform an accurate calibration.

A temperature probe **Temperature** default calculation is as follows:

$$\begin{aligned} \text{Temperature (}^{\circ}\text{C)} &= (\text{Voltage} - 2.73) \times 100 \\ \text{Temperature (}^{\circ}\text{F)} &= (\text{Voltage} - 2.73) \times 180 + 32 \end{aligned}$$

To perform a single-point calibration on a temperature probe:

1. Go to **Modules**, in the **CAN Modules** table select an **ADIO** and select the **GO TO** button to view the available **Temperature Inputs**.
2. Form the **Temperature Inputs** table, choose from the available temperature inputs and select the **GO TO** button
3. Set the **Calculation Offset** to zero.

Do not confuse **Calibration Offset** with **Calculation Offset**. You should only read and change values in the table labeled **Temperature Probe**.

Setting the offset to zero will make the temperature reading very high and may cause temperature compensation and other temperature alarms to activate.

4. Measure the actual temperature at the probe.
5. Record the measured value: _____ °C or °F.
6. Subtract the displayed value: _____ °C or °F, from the web interface.
7. Calculate the new offset: _____ °C or °F. Calculation Offset = Measured Value - Displayed Value
8. Select the **EDIT** button of the **Offset** field. Enter the new offset in degrees and select **Save**.
9. Verify that the **Offset** field was updated, and that the new displayed value matches the measured value.

21.1.5. Test relays

To test relays:

1. Go to **Modules** and select the **GO TO** button of the device to be tested.
2. In the **Relays** table, select the **Test Relay** button of the selected relay.
3. If the relay is in and energized state it will become de-energized for one minute. If it is de-energized, it will be energized during the test. To end the test early, select the **Stop Test** button.
4. Relays can also be tested by going to the individual relay menu.

21.1.6. Test comms lost action

To test the comms lost action feature:

1. Go to **Modules** and select the **GO TO** button of the device to be tested.
2. In the **Relays** table, select the **GO TO** button of the relay to be configured for the **Comms Lost Action**.
3. Ensure the relay's normal position is set to **Energized**.
4. Once configured, go to **Controller > Communication > CAN** and disable each enabled CAN bus.
5. Wait five minutes.
6. After five minutes the relay configured as a comms lost relay will de-energize. To confirm, verify the relay state using a digital multimeter. Re-enable the CAN buses and the relay will energize.



Notice: The **Comms Lost Action** is only available on controller version 6.10 and later, and firmware in the CAN module must have a version that supports this feature.

21.1.7. Enable temperature sensor failure alarms

The **Temperature Sensor Failure** alarm activates if the voltage on the temperature input is below or above the operating range of the input. If the sensor is unplugged, the voltage will be zero and the alarm activates. If you accidentally apply bus voltage to the temperature input, the alarm activates.

To enable temperature sensor alarms:

1. Go to **Modules** and select the **GO TO** button on the device with **Temperature Sensors**.
2. In the **Alarms** table there is one alarm for each temperature sensor on the ADIO module. Select the **GO TO** button to enable or disable the alarm for the required sensor.
3. Assign a relay or any other parameters as required.

21.1.8. Ground fault detection

Ground fault detection is available on the Cordex® CXC HP HV-ADIO smart peripheral.

21.1.8.1. Cordex® CXC HP HV-ADIO ground fault detection

The Cordex® CXC HP HV-ADIO peripheral has a ground fault detection (GFD) feature, under the **Modules > HV-ADIO** menu in the **Configuration** table, which can be enabled or disabled. It is disabled by default.

When disabled, the two related values (GFD Resistance and GFD Current) read **Unknown**, and no GFD-related alarms are triggered. These values are found under the **GFD Information** table.

When enabled, the resistance and current across the GFD circuit is reported under the **GFD Information** table. There are two alarms related to the GFD located in the **Alarms** table of the Cordex® CXC HP HV-ADIO peripheral.

- **Ground Fault Resistance Low** alarm will be raised if the resistance is lower than the configurable threshold, which is 20000 ohms by default.
- **Ground Fault Current High** alarm will be raised if the current is higher than the configurable threshold, which is 1 mA by default.

21.2. Module firmware upgrades

This section covers how to upgrade the firmware on CAN devices attached to the controller.

21.2.1. Module firmware upgrade

To upgrade the firmware on a module, go to **Modules** then go to **Firmware Upgrade** table from either the web interface or the LCD.

21.2.2. Upload a firmware file

Upload a firmware file from the LCD

From the LCD you can either choose a file uploaded from a USB drive or one from the **Local Files** folder. The **Local Files** menu contains a list of files previously uploaded via the web interface. Go to **Menu > Modules > Firmware Upgrade > File**.

Upload a firmware file from the web interface

To upgrade a module over the web interface, the firmware file must be uploaded to the controller first.

1. Go to **Modules**, In the **Firmware Files** table select the **Upload Firmware File** button.

An **Upload Firmware File** dialog displays.

2. Select **Select File** and choose the file to upload then select the **Upload** button.

Once the file is uploaded, the dialog closes. The uploaded file is now visible in the **Firmware Files** table and available to upgrade a module.

21.2.3. Select the file to upgrade

In the **Firmware Upgrade** table, there are buttons at the top to start or stop the firmware upgrade. These buttons are not active until a firmware file is selected. The first three rows of the **Firmware Upgrade** table display information about the selected upgrade file.

The rest of the table rows show information about the last upgrade that occurred. In the following **Ready to Start Upgrade** figure, the controller has been recently reset and no upgrade history displays.

The **File Info** field is informational, it displays information about how to proceed with an upgrade. Before a file is selected it displays the message, **Select a Firmware (ACAN) File**.

The **File** field is used to select a file for the upgrade. From the web, the upgrade file must be chosen from those previously uploaded to the controller. On the LCD, you can select either from the list of previously uploaded files (Local Files), or from a USB drive.

Once a file is selected, the first three rows of the table are updated with new status. If the file chosen is not a valid upgrade file, or if there are no modules to which that file can be applied, the number of **Modules Compatible With File** will be 0, and the **File Info** field will say, **Select a Different Firmware File**.

If the file is valid and applicable to your modules the **Modules Compatible With File** field will display how many devices need to be upgraded, and the **File Info** field will display **Ready to Start**. If the number of **Modules Compatible With File** is smaller than you expected or zero, it may be because some or all of the modules have already been upgraded to this version. There is no need reload a module with the same version of firmware. If the firmware is corrupt, the module will detect it and go into a **Waiting for Software** state.

If an upgrade has been completed since the last restart, the bottom rows of the table will still contain information about that last upgrade until the **Start Firmware Upgrade** button is selected.

21.2.4. Upgrade the module

Once a valid firmware file is uploaded and the **File Info** field displays, **Ready to Start**, select **Start Firmware Upgrade**.

As the upgrade progresses, the **Firmware Upgrade** table updates with information about the upgrade. The **Last Upgrade Percent Complete** counts up from 0 percent, and then **Last Upgrade Remaining Modules** counts down (if there is more than one module being upgraded).

If there is more than one module being upgraded, the percent complete will show the total (100 percent will be reached once all modules are upgraded) instead of a per-module completion.

The firmware upgrade can be stopped if necessary. If you select **Stop Firmware Upgrade** button the controller finishes upgrading the current module so as not to leave it in a non-functional state. If multiple modules are queued, the next module will not be upgraded.

If the upgrade fails on a module, the controller stops the upgrade and will not attempt to continue on any further modules that have been queued.

Once the upgrade is finished, the **Last Upgrade Percent Complete** displays **100%**, and the **Last Upgrade Status** displays **Succeeded**.

22. Using custom views, data, timers, counters, scheduler, and custom actions

This section covers the following:

- Custom views
- Custom data
- Timers
- Counters
- Scheduler
- Custom actions

22.1. Custom views

The **Custom Views** feature allows you to create and customize a unique view. For example, a **Custom View** may be created to make a new dashboard view with its own unique components.

Components for a new **Dashboard View** can include:

- A pre-existing table from the controller or systems.
- A new custom table with status and configuration values.
- A new custom table with inventory values.

Components for a new **Custom Data View** can include:

- A new custom table with inventory values.

22.1.1. Create custom views

To create a custom dashboard view:

1. Go to **Controller > Settings > User Interface > Custom Views** table.
2. In the **Custom Views** tab select either the **Add Custom Dashboard View** or **Add Custom Data View** button.
3. Select the **GO TO** button to open the **Configuration** and **Components** tables.
4. In the **Configuration** table, give your new *Custom View* a name and description.

22.1.2. Add components in the custom view

The **Components** table has three buttons: **Add Existing Table**, **Add Custom Table with Status and Configuration**, and **Add Custom Table with Inventory**.



Notice: Depending on the type of view you choose, not all the component options will be available.

The **Add Existing Table** option allows you to add tables from the controller or its systems.

The **Add Custom Table with Status and Configuration** or **Add Custom Table with Inventory** will add a new row entry in the Components table.



Notice: Components will not display in the order that they were added. Tables will display in the following order: Existing Tables, Custom Tables with Status and Configuration, and Custom Tables with Inventory.

22.1.2.1. Add an existing table to custom view

The **Add Existing Table** wizard allows a user to add tables from the controller or its systems. These tables are then displayed in the Custom View.

To add an existing table to the custom view:

1. Select the **Add Existing Table** button within the **Components** table to launch the wizard.
2. In the **Select Table Source** page, select the source of the table. Select **Next**.
3. In the **Select Tables** page, select the tables that will be added into the components table for the Custom View. Select **Next**.



Notice: Not all tables will be visible. If values from levels lower than what is visible are required, it is recommended to create a Custom Table component.

4. Review your selections. Select **Next**.
5. The **Results** page notify you that your components have been successfully added. Select **Done**.

22.1.2.2. Add a custom table with status and configuration

A **Custom Table with Status and Configuration** allows a user to create a table which displays status or configuration values from the controller.

To add status and configuration values to a table:

1. Select the **Add Custom Table with Status and Configuration** button within the **Components** table to create a custom table.
2. Select the **GO TO** button on the newly created table.
3. Select the **Configure Custom Tables** button to launch the configuration wizard.
4. Follow the **Configure Custom Table** wizard until complete.

22.1.2.3. Add a custom table with inventory

A **Custom Table with Inventory** allows a user to create a table which displays inventory values from the controller. This table allows for smaller groupings of the same type of item. For example, a user may want to only view ten custom data items from a list of over 100.

To add inventory values to a table:

1. Select the **Add Custom Table with Inventory** button within the **Components** table to create a custom table.
2. Select the **GO TO** button on the newly created table.
3. Select the **Configure Custom Tables** button to launch the configuration wizard.
4. Follow the **Configure Custom Table** wizard until complete.



Notice: Only the same type of inventory can be added to this custom table. For example, Delay Timers and Interval Timers can be added into this table, but Counters or Custom Data cannot.

22.1.3. Access and configure the default custom dashboard view

Access a custom dashboard view

All Custom Dashboard Views can be accessed via the navigation bar on the web interface. Custom Dashboard Views can be accessed and selected in under the **Dashboard** dropdown menu.

Configure a default custom dashboard view

A user may configure one dashboard as the default dashboard. The selected dashboard will be displayed when the **Dashboard** menu button is selected.

The default dashboard selection can be made under **Controller > Settings > User Interface**. In the **Default Dashboard** you can select the value.

22.1.4. Access the custom data view

Once you have created custom data you may select to view only this **Custom Data View**.

To select your custom data view:

1. Go to **Controller > Programmability > Custom Data**.
2. In the top right-hand corner you will find a dropdown menu. Choose your newly created custom data view.
3. At any point you may choose **All Custom Data** to return to the default display settings.

22.1.5. Remove a table from the custom view

Your custom view may reference a table from a system that has been deleted.

To remove a table from the custom view:

1. In the **Custom View**, make note of the name of the table from the deleted system.
2. Go to **Controller > Settings > User Interface**. In the **Custom Views** table navigate into the **Custom View** associated with the issue.
3. In the **Components** table, locate the table name from the deleted system.
4. In the **Actions** column of the Components table, select **Remove**.
Going back to the **Custom View**, the table will no longer be visible.

22.1.6. Add an existing table to the custom view

Your custom view may reference a table from a system that has been deleted.

To re-add an existing table:

1. Re-instate the previously deleted system to the controller.
2. Go to **Controller > Settings > User Interface**. In the **Custom Views** table, navigate into the **Custom View**.
3. Select the **GO TO** button.
4. In the **Components** table, launch the **Add Existing Table** wizard to add the required table that was unlinked/missing.

22.2. Custom data

The **Custom Data** feature allows you to create complex expressions that can be used to:

- Provide flexible ways to monitor and control a system
- Create custom conditions for user alarms and relay control

Custom data can be used to calculate values that represent voltages, digital inputs, or currents in the system.

For example, in a system that has multiple load shunts, custom data can be used to sum all the shunt currents, and then the custom data result can be mapped to a single-load inventory item in a DC system. Custom data can also be used as the input condition for a user alarm that allows for custom control of relay outputs on ADIO modules.

22.2.1. Configure custom data

Custom data has four configuration fields:

- **Name**
- **Description**
- **Equation**
- **Numeric Units and Precision**

There are also fields to help troubleshoot and fix equations that are not parsing correctly: **Custom Data Status**, **Error Position**, **Error Token** and **Expected Token**. These fields provide hints to potential equation parsing errors.

The result of the parsed equation can be displayed in three formats, as a numeric, boolean (true / false), or as text.

- The **Result as Numeric** may show a number with up to six decimal places, if the value is numeric. Results of a boolean expression will show the conventional representation of *True* as 1.000000 and *False* as 0.000000. The number of decimal places and units shown can be set using the **Numeric Units and Precision**.
- The **Result as Boolean** expresses the parsed equation as true or false. Any value greater than 0.000001 or less than -0.000001 is true.
- The **Result as Text** uses the entries in the **Text Mapping** table to map the result as numeric or the result as boolean to meaningful text.

The custom data **Equation** field is constructed from a combination of operators, numbers, variables and functions. **Counters** and **Timers** are also supported and are described in a separate section.

Operators

Custom data supports the following arithmetic and logical operations:

- Add "+"
- Subtract "-"
- Divide "/"
- Multiply "*"
- AND "&"
- OR "|"
- Less than "<"
- Greater than ">"
- Equal "="
- Parenthesis "(" and ")"
- Unary minus "-"

Number formats

Custom data supports the following formats for numbers:

- Decimal: "10.33" or "- 4.7" or "0.45" or ".45"
- Integer: "10" or "-4"

Variables

There are two kinds of variables: numeric and state.

Numeric variables can be used for:

- ADIO voltage, shunt, and temperature



Notice: When using any temperature value as a variable, the value shown in the **Variables** table may appear in units of Celsius or Fahrenheit depending on the selected language. However, when the variable is used in the custom data equation it will always be evaluated using the internal representation in units of Celsius. If the calculations must be done in units of Fahrenheit it is necessary to explicitly convert the value in the equation itself. For example, if the variable is named "T" and is showing as "71.3°F", then the equation should use " $(T \times 1.8 + 32)$ " instead of just "T". This will convert the internal Celsius value of "21.8" to the Fahrenheit value.

- System values including **Total Load Current, Time Remaining in Equalize**



Notice: Some time-spans such as **Time Remaining in Equalize** may appear in the format "d h m s" rather than in decimal form. In this case, the time unit used to evaluate the custom data equation will be shown in the selection panel when choosing the numeric variable's **Field** source; the unit will be shown in parenthesis. For example, if the variable value shows as "1h 10m (m)", then the equation will be calculated using 70 minutes.

- System inventory values including **Load Breaker/Fuse, Countdown to LVD, Load Disconnect**.
- Rectifier group values including **Estimated AC Mains Voltage, Total Output Power, Number of Failed Rectifiers**.
- Converter group values including **Total Installed Capacity, Number of Acquired Converters**.
- Counter and Timer values including, **Counter Output, Delay Time Remaining**.
- Other **Custom Data**.

State variables can be used for:

- Alarms states (active, disabled, acknowledged, ...)
- Battery Modes (charging, discharging, conditioning, ...)
- Charging states (idle, active, ...)
- Breaker states (open, closed)
- Digital inputs (active, inactive)
- Disconnect states (active, inhibited, pending, inactive, ...)

A state variable compares the live value of a state field to up to four of its possible values. The possible values are called “True If” values since the state variable will evaluate to True if the state field matches any of the possible values.



Notice: *State variables will always evaluate to True or False. A state variable should always be used with a value that represents a state. Numeric values should not be used when creating a state variable.*

Tips on using variables:

- The keywords “True” and “False” can also be used in an equation. They are treated as built-in variables that represent the value of one and zero.
- Variables are created within the context of a single unique instance of **Custom Data**. A variable created for use in a specific **Custom Data** equation cannot be reused in another equation.
- Variable names must adhere to a specific format. The name must start with a letter, followed by letters, digits or underscores. Some valid names are “T1”, “T_1”, “Vbat”, “BatteryCurrent”, “Load_2_Current”.
- Short but meaningful names offer the best readability when used in an equation.

Once a **Custom Data** has been created it can be used throughout the controller and systems as input to various configurations.

For example, in a **User Alarm** all **Custom Data** equations are displayed in the selection list of the **Source** field. You can use this **Custom Data** to alarm and control relays based on any custom parameters required.

Another example is configuration for a load. The **Load Current Source** field displays all **Custom Data** so you can sum multiple currents to represent the load current.

Generally, any **Source** field that allows you select inputs will also provide all **Custom Data** as an option.

Functions

There are three supported functions: `abs()`, `sqrt()`, `power()`. The `abs()` and `sqrt()` accept a single input parameter, and the `power()` accepts two parameters. For the `power()` function, the first parameter is the base and the second parameter is the exponent. For example, `power(2,3)` would evaluate to 8.

22.2.1.1. Showing the result as text

Custom data equations normally represent a numerical or boolean (true / false) value. At times though, it may be convenient to display those values on the dashboard as text; this can be especially useful if the custom data represents a system state. For example, an air conditioner may be *Off*, *Cooling*, or *Error*.

The **Result as Text** entry in the **Configuration** table uses the entries in the **Text Mapping** table to map the result as numeric or the result as boolean to meaningful text.

On the details page of a row in the text mapping table, there are 4 entries:

- **Name:** This is the name of the mapped text. It will appear as the custom data's **Result as Text** if it is the highest priority mapped text that evaluates to true.
- **Logic:** The logical condition used to test if this text mapping is true. If the Logic is set to Equal-to, Greater-than or Less-than, it is tested against the **Result as Numeric**. If the Logic is set to Is-True or Is-False, it is tested against the **Result as Boolean**.
- **Limit:** The value used to test against an Equal-to, Greater-than or Less-than logic condition. For equal-to logic, the **Result as Numeric** must be within +/- 0.00001 of the Limit to evaluate to true. The **Limit** has no effect for Is-true or Is-false logic. The number of decimal places and units shown can be set using the custom data's **Numeric Units and Precision** entry.
- **Priority:** This is the evaluation priority of the mapped text. The name of the highest priority mapped text that evaluates to true is assigned to the **Result as Text**; priority 1 is highest, 6 is lowest.

The picture below shows an example of how the text mapping table might be configured for a custom data representing an air conditioner's state. In this example, the **Result as Text** will show as "Off" for any **Result as Numeric** value less than 0.5, and will show as "Cooling" when the **Result as Numeric** is equal to 1. Note that there is no mapped text for numeric values between 0.5 and 1; meaning within this range, the **Result as Text** will show as unknown, "- -". Also note, that if two mapped texts are true at the same time, the **Result as Text** will display only the mapped text name with the higher **Priority**; priority 1 is highest, 6 is lowest.

Figure 22-1 Text mapping for a custom data representing air conditioning states

Text Mapping				
<p>Help</p> <p>The Result as Text is set to the highest priority mapped text that is true.</p>				
Name	Logic	Limit	Priority	
Off	Less than	0.5	1	GO TO
Cooling	Equal to	1.0	2	GO TO
System Error	Greater than	1.5	3	GO TO
Text 4	---	---	4	GO TO
Text 5	---	---	5	GO TO
Text 6	---	---	6	GO TO

Once the text mapping is complete for the given custom data, it can be selected as one of the dashboard values for a system (configured from the **User Interface Preferences** menu) for quick viewing on the LCD dashboard, or the web UI system summary.

22.2.2. Create custom data

Creating custom data can be challenging, depending on the complexity of the equation required. The following section describes a basic work flow that applies to all custom data, followed by a more detailed work flow for how to create an equation with multiple variables.

Finally, there are two examples provided: one for summing shunt readings for a load, and a second for creating a user alarm to detect if an air conditioning unit in a room is set too low.

22.2.3. Create custom data - basic work flow

The basic work flow for custom data is the same, regardless of what kind custom data is being created.

To create new custom data here is the basic work flow:

1. Create the new **Custom Data**.
2. Configure a **Name** and **Description**.
3. Create the variables.
4. Enter the equation.
5. Verify that the equation is valid.
6. Test the equation.

22.2.4. Create custom data - detailed work flow

The following steps describe a general, detailed work flow for creating custom data.

1. Go to **Controller > Programmability > Custom Data**. This table displays all the custom data available in the controller.
2. Select the **Add Custom Data** button. A new custom data line displays. Select the **GO TO** button.
3. There are three tables: **Configuration**, **Variables**, and **Text Mapping**. The **Variables** table shows all the variables that have been created for this custom data. Initially it will be empty. The **Text Mapping** table is used to map numeric and boolean (true / false) results into the **Result as Text** entry in the **Configuration** table.
4. In the **Configuration** table, enter a name and description for your custom data. The description is optional but a name is highly recommended.
5. In the **Variables** table, select the **Add Numeric Variable** or **Add State Variable** button depending on the type of variable to be used. A new variable line will display, select the **GO TO** button.
6. In the new variable table, enter: **Name**, and optionally a **Description**. Give the variable a short, but meaningful name (with no spaces) because this is the name used in the equation.
7. Select the **Field EDIT** button, and a selector screen displays. To use the selector, select an item from the left-most column. A new set of selections displays to the right. Select until you have the value needed. Select **Save**.

Once a field is selected, the bottom area of the screen displays the name, value and additional information within the **Help** text.

8. If this is a state variable, also select up to four "True If" values.
9. Repeat steps 5 through 8 to create as many variables as required.
10. After all variables have been created, select the **EDIT** button for the **Equation** field on the **Configuration** table. Enter the desired equation.
11. Verify that the **Custom Data Status** field shows **Valid**. If it does not, use the information provided to find and fix the error. The **Error Position**, **Error Token** and **Expected Token** may provide helpful information.

If possible, test the equation to ensure it is providing the expected value.

22.2.5. Custom data examples

The following two examples illustrate the process of using **Custom Data** for summing load shunt currents and detecting if interior air conditioning is set too low and creating a **User Alarm**.

22.2.6. Custom data - summing load shunts

The following example shows how to create custom data that sums up three shunt currents, and maps the result to the system load inventory item.

1. Use the steps in the detailed work flow to create custom data which sums up three variables to compute a value for the total load current in a system. When selecting a current reading, it must be selected from a shunt in the system, not at the ADIO module input.
2. To set up the **Load** to use this **Custom Data**, go to **Systems > DC System > Inventory > Loads**, then select the **GO TO** button for the **Load** that will represent the sum of the three shunts.
3. In the **Configuration** table, select the **EDIT** button to edit the **Load Current Source** entry, and select the Custom Data's **Result as Numeric**.
4. When configured, the Load Current Source will use the custom data created in step 1 which will display the summed current of the three shunts on one load.

The load current now correctly shows the sum of the three shunts.

22.2.7. Custom data - AC cooling too low user alarm

The following example shows how to create a **User Alarm** that is active if it appears that the air conditioning in the room is set too low.

1. Use the steps in the detailed work flow to create custom data that has an equation which evaluates to "true" if the outdoor temperature is greater than 25°C (77°F), if the outdoor temperature is greater than the indoor temperature, and if the difference is greater than 5°C (41°F).
2. To set up a **User Alarm** to use this **Custom Data**, go to **Controller > Programmability > User Alarms**.
3. Select **Add Digital User Alarm**, and select the **GO TO** button to edit the alarm details.
4. Configure the alarm name, relay and any other information required.
5. In the **User Alarm** table, select the **EDIT** button on the **Source** line, and then select the **Custom Data** created to detect if air conditioning is set too low.

The **User Alarm** activates if the indoor temperature is too low as compared to the outdoor temperature.

22.3. Using timers

Using the **Timers** feature you create two types of timers: a delay timer or an interval timer.

- The **Delay Timer** can be used with **Custom Data** to produce a programmable delay when a certain event happens.
- The **Interval Timer** can be used with **Custom data** to measure the time between two events.



Notice: *An event is defined as a boolean expression that transitions from false to true or not unknown to true. Since some logical conditions can evaluate to unknown, for example when data cannot be retrieved from a CAN module, it is important to construct events so that they always transition from false to true.*

For example, a **Delay Timer** might be configured to delay the start of a generator once the voltage falls below a certain value. An **Interval Timer** might be used to measure how many generator restarts occur in a 24-hour period.

22.3.1. Configure the delay timer

A **Delay Timer** has eight configuration fields:

- **Name:** The editable name of the item.
- **Description:** Additional information to describe the item.
- **Delay:** The amount of time set for the timer delay. For custom data calculations this value is measured in seconds. For example, a value shown as '1m 3s' will be considered as 63s in the equation.
- **Auto Reset:** When enabled, the timer is stopped and the output is set to **False**.
- **Output True When:** Determines when the timer output is True - **When Running** or **When Delay Over**.
- **Retrigger:** When enabled, the timer can be continuously re-triggered when the **Trigger** goes from false to true before the delay time elapses. When the timer is re-triggered, the **Delay Time Remaining** starts counting down again from the configured delay time and the output will stay true.
- **Trigger Source:** The field that represents the **Trigger** value. It is usually set to the result of a custom data.
- **Reset Source:** An optional field that represents the **Reset** value. It is usually set to the result of a custom data.

There are also fields to describe the state of the **Delay Timer**:

- **Output:** This value will be true when the timer is on and the delay is active.
- **Delay Time Remaining:** The time remaining in the delay. For custom data calculations this value is measured in seconds. For example, a value shown as '1m 3s' will be considered as 63s in the equation.

- **Trigger:** The value of the timer trigger. When this value goes from false to true, the delay timer starts and the output goes true as long as the **Reset** value is false.
- **Reset:** The value of the timer reset. When this value is true, the timer output will be false.

The **Reinitialize Timer** button can be used if the timer configuration has been changed while the timer is active.



Notice: *It is also possible to test the timer or force it into a desired state using the **Force Timer to Start** and **Force Timer to End** buttons, even if **Start Event** has not been configured.*

- **Force Timer to Start** simulates the **Start Event** going from false to true.
- **Force Timer to End** sets the **Delay Time Remaining** going to zero and the timer going into its terminal state.

Delay timer operation

The **Delay Timer** operates as follows:

- When the **Reset** is true, or if **Auto Reset** is enabled and the timer trigger source is false, the timer output is always false and the **Delay Time Remaining** is set to the initial value.
- When **Output True When** value is **When Running** and the **Trigger** input goes from false to true, the **Output** goes true and the **Delay Time Remaining** starts counting down from the delay value.
- When **Output True When** value is **When Delay Over** and the **Trigger** input goes from false to true, the **Delay Time Remaining** begins counting down and when it reaches 0, the **Output** goes true.
- If the timer is actively counting down seconds, and the **Output** is true when the **Trigger** input goes from false to true, the timer starts counting down seconds starting from the configured delay time for as long as the **Retrigger** is enabled.
- When the **Reinitialize Button** is pressed, the timer **Output** will be set false and the **Delay Time Remaining** is set to the initial value.

22.3.2. Configure the interval timer

An interval timer has four configuration fields:

- **Name:** The editable name for this item.
- **Description:** Additional information to describe the item.
- **Start Event Source:** The field that represents the timer **Start Event**. It is usually set to the result of a custom data.
- **Stop Event Source:** The field that represents the timer **Stop Event**. It is usually set to the result of a custom data.

There are also fields to describe the state of the **Interval Timer**:

- **Output:** The output time of the timer. For custom data calculations this value is measured in seconds. For example, a value shown as '1m 3s' will be considered as 63s in the equation.
- **Start Event:** The present value of the **Start Event** field. It will evaluate to true or false.
- **Stop Event:** The present value of the **Stop Event** field. It will evaluate to true or false.

The **Reinitialize Timer** button can be used if the timer configuration has been changed while the timer is active.



Notice: *It is also possible to test the timer or force it into a desired state using the **Force Timer to Start** and **Force Timer to End** buttons even if **Start Event** and **Stop Event** have not been configured.*

- **Force Timer to Start** simulates the **Start Event** going from false to true.
- **Force Timer to End** simulates the **Stop Event** going from false to true.

Interval timer operation

The interval timer operates as follows:

- When **Start Event** goes from false to true, the timer **Output** begins incrementing seconds starting from 0.
- When **Stop Event** goes from false to true, the timer **Output** stops incrementing seconds and remains at the value it had at the Stop Event time.
- If the timer is incrementing seconds, and the **Start Event** goes false to true again, the **Output** starts incrementing seconds starting from 0.
- When the **Reinitialize Button** is pressed, the timer Output will be set to '---'.

22.4. Counters

The **Counters** feature makes it possible to create an **Up Counter** or a **Down Counter** that keeps track of events. A counter can be used with **Custom Data** as a variable in an equation.



Notice: *An event is defined as a boolean expression that transitions from false to true.*

For example, an **Up Counter** might be configured to increment whenever the battery voltage goes below a certain value to count the number of discharges that have occurred.

22.4.1. Configure the up counter

An **Up Counter** has five configuration fields:

- **Name:** The editable name for this item.
- **Description:** Additional information to describe this item.
- **Input Source:** The field that represents the **Input** value. It is usually set to the result of a custom data.
- **Reset Source:** This optional field represents the **Reset** value. It is usually set to the result of a custom data.
- **Terminal Value:** This is an optional numeric value that is the maximum value.

There are also fields to describe the state of the counter:

- **Input:** The value of the field that was selected for the **Input Source**. It will evaluate to false or true.
- **Output:** The value of the counter.
- **Reset:** The value of the field that was selected for the **Reset Source**. It will evaluate to false or true.
- **Terminal Reached:** This value is true when the counter **Output** is equal to the **Terminal Value**.

The counter also has a **Reinitialize Counter** button. When this button is pressed, the counter **Output** is set back to zero.

Up counter operation

The **Up Counter** operates as follows:

- When the **Input** value goes from false to true, the **Output** will increment by one, as long as it is less than the terminal value and the **Reset** value is false.
- When the **Reset** value is true, the **Output** will always be zero.
- The **Terminal Reached** value will be true whenever the **Output** is equal to the **Terminal Value**.
- When the **Reinitialize Counter** button is selected, the counter **Output** is set to zero. This allows for a manual reset of the counter in case the **Reset Source** has not been configured.

22.4.2. Configure the down counter

A **Down Counter** has five configuration fields:

- **Name:** The editable name for this item.
- **Description:** Additional information to describe this item.
- **Input Source:** The field that represents the **Input** value. It is usually set to the result of a custom data.

- **Initialize Source:** This optional field is used to represent the **Initialize** value. It is usually set to the result of a custom data.
- **Initial Value:** The initial value of the **Down Counter**.

There are also some fields to describe the state of the counter:

- **Input:** The value of the field that was selected for the **Input Source**. It will evaluate to false or true.
- **Output:** The value of the counter.
- **Initialize:** The value of the field that was selected for the **Initialize Source**. It will evaluate to false or true.
- **Counter at Zero:** This value is true when the counter **Output** is equal to zero.

The counter also has a **Reinitialize Counter** button. When this button is pressed, the counter **Output** is set back to the initial value.

Down counter operation

The down counter operates as follows:

- When the **Input** value goes from false to true, the **Output** will decrement by one, as long as it is greater than zero and the **Initialize** value is false.
- When the **Initialize** value is true, the **Output** will always be equal to the **Initial Value**.
- The **Counter at Zero** value will be true whenever the **Output** is equal to zero.
- When the **Reinitialize Counter** button is pressed, the counter **Output** is set to the **Initial Value**. This allows for a manual reset of the counter in case the **Initialize Source** has not been configured.

22.5. Scheduler

The **Scheduler** feature makes it possible to create actions which can occur or recur at specific times or dates. With this feature you can:

- Schedule a single action.
- Schedule a recurring action, hourly, daily, weekly, or monthly.

The **Scheduler** can be used to do the following:

- Equalize the batteries on a DC system.
- Run a battery test on a DC system.
- Put a DC system back into float mode (canceling any equalize or battery test).



Notice: *Equalize or Battery Test have user configurable termination conditions in their menu settings, therefore it is generally not necessary to schedule an end within Scheduler.*

22.5.1. Configure a recurring action

To create a recurring action:

1. Go to **Controller > Programmability > Scheduler**. A table displays available options.
2. Select the **Create Scheduled Action** button to launch the wizard.
3. Follow the instructions to set up the schedule type, start date and time, recurrence interval, actions, and an end condition if required.

The table displays the new **Scheduled Action**, and when that action will run.

A **Scheduled Action** can also be triggered manually by selecting **Trigger Action Manually**. This is intended to be used for testing during configuration.

22.6. Configure a one-time action

To create a one-time scheduled action:

1. Go to **Controller > Programmability > Scheduler**. A table displays available options.
2. Select the **Create Scheduled Action** button to launch the wizard.
3. Follow the instructions to set up the **One Time, Scheduled type**, and the **Action** to be performed.

22.7. Configure scheduled actions

The controller wizard is used to create and configure scheduled actions, with the exception of the **Action** field. The **Scheduler** has five configuration fields. The first four can only be configured via the wizard.

- **Schedule Type:** One time, hourly, daily, weekly, or monthly.
- **Start Date and Time:** This is the date the event takes place. For recurring events, time is the specific time of day each event runs (with the exception of hourly events).
- **Recurrence Interval:** The time between occurrences (every three hours, every six months, ...).
- **End Type:** Can be set to never end, end by a date, or end after a certain number of occurrences.
- **Action:** The specific action that runs at each interval.

Additional fields describe the state of a scheduled action:

- **Recurrence:** A message describing when and how often an action will occur.
- **End:** A message detailing when a recurring actions will end.
- **Scheduled Status:** A message describing either “waiting”, “completed” or “missed”.
- **Last Run:** The time the last action ran.

- **Next Scheduled Run:** The time the next action will run.
- **Total Executed Runs:** The total number of times this scheduled action has run.

In addition to the information listed in the fields, the Event Log will contain a message each time an action has run or been missed.



Notice: *In situations where the controller has been off and Daylight Savings Time occurs, the Scheduler runs actions up to one-hour after they are scheduled to run. **For example**, if an action is scheduled for a single occurrence, at 9/1/2017 4:00PM, and the controller is off at 3:30PM and back on at 4:30PM, then the scheduled action will still run.*

22.8. Scheduled time spans

The **Scheduled Time Span** is used to create a daily time span using custom data, or other features that can take a boolean input (true or false, yes or no).

Using the **Scheduled Time Span**, you can configure the following:

- A name for easy identification. For example, “Morning Rush Hour”.
- A start time and end time.
- A scheduled date range, such as, on all days, on weekdays only, or on weekends only.

Once configured, the **Scheduled Time Span** outputs a boolean signal called **Within Time Span**. This value is true if the current time is within the time span, and false otherwise.

This boolean signal can be used in custom data to indicated whether or not the controller is operating within a given time span. One example is to create a custom data equation that would only be evaluated during certain periods of the day, or conversely, not evaluated during certain periods of the day.

22.9. Custom actions

The **Custom Action** feature makes it possible to change a relay or field to different values based on a condition. With this feature you can:

- Activate/deactivate a relay based on a condition.
- Change the value of a numeric configuration field based on a condition.
- Change the value of a numeric configuration field to the value of a **Custom Data**.

22.9.1. Configure a change relay action

Change Relay actions can be used to control equipment, external to the system, based on specific conditions. For example, in a case where external equipment should be turned on or off based on the state of the controller (that is, turn a generator on when AC is lost). In this specific example, the condition would be to check if power has been lost, if yes, then the Relay To Change would activate, turning on the generator. To access this feature go to **Controller > Programmability > Custom Data**.

A **Change Relay Action** has four configuration fields:

- **Name:** The editable name for this item.
- **Description:** Additional information to describe this item.
- **Relay To Change:** The relay that will be changing based on the specified condition.
- **Condition:** A boolean field that will control the relay.

There are also fields that describe the state of the action:

- **Field Value When Condition True:** What state the relay will be in when **Condition Value** is true.
- **Field Value When Condition False Or ---:** What state the relay will be in when **Condition Value** is false or unknown.
- **Condition Value:** The present value of **Condition**.
- **Field Value:** The present value of **Relay To Change**.

Change relay action operation

The **Change Relay** action operates as follows:

- When the **Condition Value** is false or unknown, the relay will be in its normal state.
- When the **Condition Value** is true, the relay will be in its abnormal state.

22.9.2. Configure a change field to constant action

The **Change Field To Constant Action** feature can be used to change the value of a field based on specific situations. This can be useful to control the state of the system based on external conditions. For example, when a generator is on, the system can be set to charge the batteries at a lower rate so that it does not drain the generator.

To access this feature go to **Controller > Programmability > Custom Data**.

A **Change Field To Constant** action has six configuration fields:

- **Name:** The editale name of this item.
- **Description:** Additional information to describe this item.
- **Field To Change:** The field that will be changing based on the specified condition.
- **Condition:** A boolean field that will cause **Field To Change** to change to different values.
- **Field Value When Condition True:** The value of **Field To Change** when **Condition Value** is true.
- **Field Value When Condition False Or ---:** The value of **Field To Change** when **Condition Value** is false or unknown.

There are also fields that describe the state of the action:

- **Condition Value:** The present value of **Condition**.
- **Field Value:** The present value of **Field To Change**.

Change field to constant action operation

The **Change Field To Constant** action operates as follows:

- When the **Condition Value** is false or unknown, **Field To Change** will be set to **Field Value When Condition True**.
- When the **Condition Value** is true, **Field To Change** will be set to **Field Value When Condition False Or ---**.

22.9.2.1. Configure a change field to constant action

One way to use a **Change Field To Constant Action** is to set **Auto DC Priority**. The following describes how to configure a **Change Field Action To Constant** to control the amount of power the Inverter System takes from DC, based on the time of day.

Go to **Systems > Inverter System > System Functions** and in the **Manual DC Priority** table, ensure that **Manual DC Mode** is **Enabled**.

1. Go to **Controller > Programmability > Scheduler**.
2. Select the **Create Time Span** wizard to select the days and times.
3. Go to **Controller > Programmability > Custom Data**.
4. Select **Add Change Field To Constant Action**, and select the **GO TO** button.
5. In the **Configuration** table, select **Field To Change**, select the **AMPS HP2 system** and then **Desired DC Input Power**.
6. In the **Configuration** table, select **Condition > Time Span > Within Time Span**.
7. In the **Configuration** table, select **Field Value When Condition True** and set to 100%.

This causes the inverter system to pull all its power from DC during the more expensive hours for power usage.

8. In the **Configuration** table, select **Field Value When Condition False** to 0%.

This causes the inverter system to pull all its power from AC during less expensive hours of power usage, allowing the batteries to charge during that time period.

22.9.3. Configure a change field to variable action

The **Change Field To Variable Action** feature can be used to change the value of a field to the value of a **Custom Data**. This can be useful to control the state of the system based on external conditions. For example, the rectifier's power output can be adjusted based on a limit to the amount of AC power that should be consumed.

To access this feature go to **Controller > Programmability > Custom Data**.

A **Change Field To Variable** action has five configuration fields:

- **Name:** The editable name of this item.
- **Description:** Additional information to describe this item.
- **Field To Change:** The field that will have its value changed to the value of the configured **Custom Data**.
- **Set Field To Custom Data:** The value of **Field To Change** will be set to the value of this **Custom Data**.
- **Field Value Change Interval:** The number of seconds between each time the value of **Field To Change** will be set to the value of **Set Field To Custom Data**.

There are also fields that describe the state of the action:

- **Last Error Condition:** Describes if there are any errors, either with the configuration or the operation of this action.
- **Field Value:** The present value of **Field To Change**.
- **Field Range:** The range for **Field To Change**. The value of **Field To Change** will only be set if the value of the configured **Custom Data** is within this range.
- **Custom Data Value:** The present value of **Set Field To Custom Data**.
- **Time To Next Possible Change:** The amount of seconds until the next time **Field To Change** will have its value set to the value of the configured **Custom Data**, if the value is different and within range.

Change field to variable action operation

The **Change Field To Variable** action operates as follows:

- The value of **Field To Change** will be set to the value of the **Custom Data** that **Set Field To Custom Data** is configured to use.
- This value will be set on an interval based on the value of **Field Value Change Interval**. For example, if this field is set to 300 seconds (the default), the value of **Field To Change** will be set every 300 seconds.
- **Field To Change** will only be set if the value of the configured **Custom Data** is different than the present value of **Field To Change**, and is within range for this field.

23. Troubleshooting

This section covers the following:

- Troubleshoot the controller
- Troubleshoot a rectifier system
- Troubleshoot an inverter system
- Troubleshoot a line power system

23.1. Troubleshoot the controller

This section covers possible issues and fixes for your controller. Also see the readme notes that are released with the controller software.

23.1.1. No communication

Check all connection cables.

Check the controller settings, go to **Controller > Communication > Ethernet**.

Ensure that the controller is configured to communicate via the web interface. See *Getting started* and *Setting up controller communication*.

Ensure that both ports in the Ethernet table have the address mode configured correctly.



Notice: *The default IPv4 configuration for the controller must have the rear Ethernet port set to automatic (DHCP) and the front Ethernet port set to manual (static IP).*

23.1.2. Unable to communicate via ethernet

Confirm that all cables are firmly connected.

1. Go to **Controller > Communication > Ethernet**.
2. Ensure that the IP address settings are correct.
3. Edit the settings if required.
4. Select **Save**.
5. If that does not work, then restart the controller.



Important: *Selecting the reset button restarts the controller and may result in lost data. It is always recommended to use the controller **Restart** button from the menu system to ensure any outstanding configuration changes or log data is saved to disk.*

If the issue is not resolved, contact your IT department to confirm that both the controller and the computer can communicate across the network.

23.1.3. Home button or LCD screen not responding

If the controller is not responding to touch or the **Home** button is not responding to touch, you can perform a controller reset.

! ***Important:** Pressing the reset button does not ensure that the settings are saved.*



To perform a hardware reset: From the front of the controller, select the reset button.

23.1.4. Controller fail

The controller has a relay that can be used to indicate the controller power has failed. This relay is labeled **Alarm** and is located beside the power connector. In-shelf versions of the controller do not have this relay.

When the controller is operational, the relay is in the normally open (NO) position. When the controller power has failed this relay is in the normally closed (NC) position. If voltage is applied to the power connector and the **Alarm** relay is in the normally closed (NC) position and the controller does not start up, it is likely the controller has failed and should be replaced.

In-shelf controllers (for example, Cordex® CXCi HP controller) do not have a dedicated controller fail relay. Failure of an in-shelf controller may result in relays becoming de-energized. These de-energized relays function as a controller fail relay.

🔊 Notice: *The controller fail relay is not programmable in any way.*

23.1.4.1. FXM HP controller fail

Failure of the controller inside the FXM HP rugged UPS module may not result in any relay becoming de-energized since the relays are on a separate, independent CAN module.

It is recommended to use the **Comms Lost Action** setting on the **Relay Details** page. If communication is lost between the internal controller and the FXM ADIO module, the relay will de-energize five minutes after communication is lost.

This feature is available in version 6.10 and later. The CAN module firmware also needs to be updated to a version that supports this feature.

23.2. Troubleshoot a rectifier system

This section covers possible issues and fixes for your system. Also see the readme notes that ship with the controller software.

23.2.1. Relays not triggered during alarm conditions

If the relays are not triggered during alarm conditions try the following:

- Ensure alarm condition is mapped to a relay (**Alarms > All Alarm Settings**).
- Ensure polarity of the relay is set correctly
- Ensure Cutoff All Alarms had not been selected
- Ensure ADIO is communicating

23.2.2. Rectifier alarms and alerts

Alarm: An alarm is a notification of a change to the state of the controller. Alarms can be configured with thresholds (if applicable), mapped to relays and will trigger SNMP notifications.

Alert: An alert is a notification from a device that indicates a problem or change in state. An alert is not configurable. The status of an alert is viewable from a device's detailed status page. For example, to view rectifier alerts go to **Systems > DC System > Inventory > Rectifiers > Status**, and select the **GO TO** button.

Rectifier Minor Alert: Indicates a potential minor problem that doesn't pose an immediate risk to the rectifier's ability to output power.

Rectifier Fail Alert: Indicates a problem with the rectifier's ability to output power.

If the system has an active **Rectifier Minor** or **Rectifier Fail** alarm, you can find out the source and cause of the alarm as follows:

1. Go to **Systems > DC System > Inventory > Rectifiers > Status** and look at the **# Alerts** column.
2. Look for a rectifier in the list with more than zero alerts and select the **GO TO** button. The page displays a **Rectifier Alerts** table listing all possible rectifiers alerts.
3. Sort the table to find the active alerts. Select the **GO TO** button for a description of the alert. This information allows you to troubleshoot the problem.



Notice: A common reason for an unexpected Rectifier Fail alert is a very low load or no load resulting in a **Ramp Test Fail/No Output Power** alert. It is normal for a rectifier to have this alert active if there is no load or very low load. If your system normally operates at very low load you can disable the Ramp Test under **Systems > DC System > Inventory > Rectifiers > Rectifiers Configuration** to clear this alert and prevent it from activating.

23.2.3. Rectifier not acquired

Ensure all rectifiers are secured and tightly screwed into the shelf.

Ensure CAN cables are securely connected and routed between all necessary shelves, and to the controller.

Go to **Systems > DC System > Inventory > Rectifiers > Status**, and then select **Assign** in the **Modules Available for Assignment** table for the specific rectifier required.



Notice: Even if a system is configured to auto-assign devices, once a rectifier has been unassigned from the system, it must be manually reassigned back into the system. This is necessary to avoid unintentional auto-assignment. If a device is unassigned using the **Forget** button, then it will auto-assign when discovered on the CAN bus

23.2.4. Rectifier communication lost

If one or more rectifiers have lost communication with the controller for more than ten seconds an alarm generates. The alarm will clear when communication is restored to all rectifiers.

If rectifier communication is lost, check the following:

1. Check all CAN cables for breaks or loose connections.
2. Ensure all rectifiers are secured and tightly screwed into the shelves.
3. Go to **Systems > DC System > Inventory > Rectifiers > Alarms**.
4. On the alarms table, select the **GO TO** button on the **Rectifier Comms Lost** row to see the details.

23.2.5. Replacing a defective rectifier

When a rectifier fails and or is permanently removed, the system generates a **Rectifier Comms Lost** alarm.

The alarm is cleared by removing the rectifier from the system inventory.

To remove the rectifier from the system inventory:

1. Remove the defective rectifier from the shelf.
2. Go to **Systems > DC System > Inventory > Rectifiers > Status**.
3. Select **Forget** on the rectifier to be removed and confirm.

4. Place the new rectifier in the shelf.
5. Rectifiers are Plug and Play, but you may still need to map the new rectifier to an AC phase.
6. If the rectifier shows in the **Modules Available for Assignment** table, instead of in the **Status** table, select **Assign** to assign the new rectifier.
7. Confirm the assignment.

23.2.6. Using extended ranges

If your 12 Vdc, 24 Vdc, or 48 Vdc system has a battery and rectifier modules that can operate outside of the normal ranges, you can enable extended ranges to allow your DC system to run outside the normal ranges.

23.2.6.1. Extended ranges for battery testing

Normally, 12 Vdc, 24 Vdc, and 48 Vdc systems have a fairly narrow range of voltages allowed for battery testing. These voltages are based on what is considered normal for the batteries and what is possible for the rectifiers. The ranges are set this way to avoid errors when configuring a new system. The 125 Vdc and 220 Vdc systems have a wider range of battery test voltages because there are a wider variety of battery configurations used with those systems.

1. Go to **Systems > DC System > Configure System**. In the configuration table, change the **Extended Ranges (Advanced)** setting from **Normal** to **Extended**.
2. Go to **Systems > DC System > Inventory > Rectifiers > Configuration**. In the configuration table, set the **Minimum Test Voltage** to the lowest value allowed by your rectifier.
3. Go to **Systems > DC System > System Functions > Battery Test**. In the configuration table, set the **Battery Test Termination Voltage** to the voltage you want the battery test to run to.

We strongly recommend that the **Battery Test Termination Voltage** on the battery test page be at least 0.5 volts higher than the **Minimum Test Voltage** on the rectifier configuration page.

23.2.6.2. Extended ranges for battery equalization

Normally, battery equalization is a process designed to de-sulphate a battery's plates by holding a controlled overcharge over the period of a few hours. The **Extended Ranges** option will allow much longer durations than is generally used for the battery equalization process. This option helps to support systems with unusual configurations.



CAUTION: *Equalization for extended periods can cause excessive gassing and plate damage.*

1. Go to **Systems > DC System > Configure System**. In the **Configuration** table, change the **Extended Ranges (Advanced)** setting from **Normal** to **Extended**.
2. Go to **Systems > DC System > System Functions > Equalize & Boost**. In the **Equalize** table, change the **Equalize Duration** setting to the desired time length.

23.2.7. Rectifier configuration error

If there is a configuration error alarm active, check the rectifier settings:

1. Go to **Systems > DC System > Inventory > Rectifiers > Configuration**.
2. Check the **Over-Voltage Protection Threshold** value. It must be set higher than any system Equalize, Boost, Absorption, or System Voltage settings. The exact margin required depends on the type of rectifiers, but 48 volt rectifiers required at least 1 volt.
3. Check that System Float Voltage, Equalize Voltage, Boost Voltage, and the Over-Voltage Protection Threshold are set within the ranges supported by the rectifiers on your site.
4. Try setting rectifier configuration to the defaults.
5. Check the rectifier manual information about setting ranges.
6. Save any changes. It may take several seconds for the changes to take affect.

23.2.8. Rediscovering CAN devices

If all of the installed equipment doesn't display after maintenance it may be caused by defective CAN bus cables or sequencing of removal and replacement of equipment with the controller powered down removed.

1. Check that all CAN bus cables are installed and terminated.
2. Power cycle CAN devices if possible.
3. Update device firmware if needed.

23.2.9. Replacing a defective ADIO peripheral

When an ADIO peripheral fails or is permanently removed, the system generates an alarm. The alarm is cleared by removing the device from the inventory. To remove the device from the inventory:

1. Remove the defective ADIO device.
2. Install the new ADIO device and connect all the wires to the same terminals.
3. Go to **Modules**. In the **CAN Modules** table, location the ADIO and select the **Replace** button and follow the wizard instructions.
4. Check and update any other configuration parameters where required.

23.2.10. Troubleshoot a battery test

Calculations for SOH, SOC, and RTR Battery Test algorithm used by the controller are designed to work with lead acid batteries which have a Peukert exponent between 1.0 and 2.0. Check your battery manufacturers' specifications to ensure that the battery is within these constraints. When a battery is new, and fully charged, a battery test should show the battery to have 100 percent **Estimated State of Charge** and 100 percent or more **Estimated Battery Health**. If it does not, check and correct the following:

1. Is the battery properly connected?
 - a. Check the wiring between the battery, shunts, and the rectifiers.
 - b. Check that the shunts are properly connected and sized.
2. Is the configuration correct?
 - a. Go to **Systems > DC System > System Functions > Battery Runtime & Health**. Confirm that **Battery Estimation** is **Enabled**, the **Load Model** is correct for your system, and the **Battery LVD** value is correct.
 - b. Go to **Systems > DC Systems > Inventory > Battery**. Select the **GO TO** button and confirm that the **Capacity Rating** and the **Peukert Exponent** are correct.
 - c. Go to **Systems > DC System > System Functions > Battery Test**. For greatest accuracy, check that the **Battery Test Timeout**, which is the amount of time the battery test stays active before termination, has a time value that will allow the battery to reach an 80 percent depth of discharge. Check that the **Battery Test Termination Voltage** is realistic. It should be LVD + 1 volt: for example, a 24 V system would be 22 V.
3. Did anything unexpected happen during the test?
 - a. Was the load changed?
 - b. Did the AC power go out?
 - c. Was the controller restarted? Go to **Controller > About > General** and check the **Time Since Restart**.
4. Is the **Battery on Discharge** alarm active? During a discharge, it is normal to see the **Battery on Discharge** alarm activate. Two conditions are required to activate the **Battery on Discharge** alarm. 1) This alarm will activate when the battery voltage is below the battery **Open Circuit Voltage** value which can be found in **Systems > DC System > Inventory > Battery > Battery Strings > Battery String**. Note: Each battery string within the **Battery Strings** table has a **Open Circuit Voltage**. 2) The battery current is below **Current Threshold for Discharging** value which can be found in **Systems > DC System > Inventory > Battery > Charging/Discharging Thresholds**.

If any corrections were made then allow the batteries to fully recharge (at least 24 hours) before starting another battery test. If a battery test shows **Estimated Battery Health** found in **Systems > DC System > System Functions > Battery Runtime & Health** to be lower than 80 percent then the batteries should be replaced.

23.2.11. Troubleshoot power save

If **Power Save** is either **Stopped** or **Suspended** it may be due to the following conditions. Please review the following table for possible causes and solutions. From the web interface go to **Systems > DC System > System Functions > Power Save**.

Table 23-1 Troubleshooting power save

Issue	Possible cause	Solution
Power Save status is: Stopped - All Mod-	Units are not supported for power save,	Replace failed rectifiers.

Table 23-1 Troubleshooting power save (continued)

Issue	Possible cause	Solution
ules Failed, In Fold-back or Unsupported	high temperature, or low AC input voltage.	Wait for temperature to drop. For universal input rectifiers operating at 120 Vac nominal input voltage, power save cannot be used and should be disabled. These units typically can only be loaded to around 50 percent, due to low input voltage derating so power save has no beneficial effect.
Power Save status is: Stopped - Total Load Current Invalid	Incorrect configuration of load current; lost communication with rectifiers.	Check configuration of loads and shunts. Restore rectifier communication.
Power Save status is: Suspended	AC fail or battery test.	Restore AC. Wait for battery test to complete.
Power Save status is: Stopped - System Voltage Invalid	ADIO communication lost or incorrect system voltage configuration.	Check ADIO communication and restore. Check system voltage configuration.
Power Save status is: Stopped - Battery Charge Current Limit Invalid	Battery charge limit not configured.	Configure battery charge current limit.
Power Save status is: Stopped - Invalid Data	Data essential to power save cannot be computed.	Check all of the aforementioned items.
Not enough modules are on or battery is discharging	Module Power For Maximum Efficiency setting is above the maximum possible power achievable.	Check the values for current and power capacity under Systems > DC System > Inventory > Rectifiers > Configuration . These values limit the maximum output power achievable by the rectifier and should be set to 100 percent.

23.3. Troubleshoot an inverter system

Incorrect system configuration

If the system has been incorrectly configured with the wrong number of phases, the commissioning wizard will need to be executed again.

If the number of **DC Groups** is incorrect, it is likely that some inverters have the incorrect DC group number. It is possible to fix this by manually changing the DC group number in the details screen of each inverter.

If the number of shelves per phase is incorrect, it is likely that some inverters have the wrong bay ID, shelf ID, or slot ID. It is possible to fix this by manually changing these values in the details screen of each inverter.

The details screen for an inverter can be found at **Systems > Inverter System > Inventory > Inverters > Status**. Select the **GO TO** button for the inverter of interest.



Notice: Executing the commissioning wizard will turn off the inverters and will require them to be unplugged! The system must be bypassed or the load taken off line.

23.3.1. Wrong inverter AC input group

An inverter's AC input group number is set automatically to the same value as the output phase number. It may take a minute or two for the number to be reflected on the user interface. If this number seems incorrect, unplug the inverter, wait for the fan to stop turning, and then reinsert it.

23.3.2. Wrong inverter DC input group

The DC input group number is set automatically during commissioning, based on the configured number of DC groups as well as the slot ID. If this number seems incorrect, it can be changed from the details screen of the inverter.

23.3.3. T2S expert operations

To thoroughly troubleshoot an inverter system, there are some expert operations that a user may need.



Notice: These operations are not normally needed during operation of an inverter system. They should only be used by qualified technicians or under the guidance of technical support (www.alpha.ca/support)

These expert operations are:

- **Get Configuration File from T2S**
- **Upload Configuration File to Controller**
- **Send Uploaded Configuration File to the T2S**
- **Get Log file from T2S**
- **Clear History Log**
- **Turn Off Inverters**

- **Turn On Inverters**
- **Configuration Helper**

23.3.4. Troubleshoot and clear the system error alarm

Occasionally the inverter system will activate a **System Error** alarm. This may happen after momentary AC outages, breaker trips, false communication problems, or other unusual events. The **System Error** alarm is a reminder to check the T2S log file. It is recommended to download and view the log file for any possible problems. Downloading the log file will also clear the alarm.

To check the T2S log file:

1. Determine which T2S is the source of the alarm. Navigate to **Systems > Inverter System > Live Alerts** and look for the *Check Log File* alarm in the list. Whenever the *Check Log File* alert is active, the *System Error* alarm will also be active. The *Check Log File* alert will be shown with the serial number of the T2S that is causing the alert.
 2. Go to **Systems > Inverter System > Inventory > T2Ss** and select the **GO TO** button of the T2S identified in the previous step.
 3. In the **T2S Expert Operations** table, select **Get Log File from T2S**. This will initiate a transfer of the log file from the T2S.
 4. Once the log file has been received, select **Download** to save the file to your computer.
 5. Open the file and look for any event entries that might indicate a persistent issue. For example, module failures or communication problems. These problems may indicate the need to replace a module or inspect communication wiring.
- Once the log file has been transferred from the T2S, the **System Error** alarm will clear.

23.3.5. Phase saturation alarm

The **Phase Saturation** alarm indicates that one or more phases are drawing too much power. The alarm activates when the ratio of actual output power, over the total installed power (excluding redundant inverters), exceeds the **Saturation Alarm Threshold** parameter configured on the T2S controller. This value is normally set to 100 percent. To verify the threshold value download the T2S configuration.

To check the T2S Saturation Threshold:

1. Go to **Systems > Inverter System > Inventory > T2Ss** and select the **GO TO** button of the T2S identified in the previous step.
2. In the **T2S Expert Operations** table, select **Get Configuration File from T2S**. This will initiate a transfer of the configuration file from the T2S.
3. Once the file has been received, select **Download** to save the file to your computer.
4. Open the file in a text editor and search for "Saturation alarm threshold". The search should find a line similar to: ";556; ;Saturation alarm threshold ; ;80; ;%; ". The value 80 indicates the threshold is 80 percent.

5. If required, this value can be changed. The recommended value is 100. Change the value directly in the text editor and save. Ensure that only the value is changed and the enclosing semicolons are preserved.
6. Return to the controller interface and select **Upload Configuration File to Controller** in the **T2S Expert Operations** table.
7. Select the T2S configuration file that was just edited, and then select **Upload**.
8. In the **T2S Expert Operations** table, the **Send To T2S**. Wait for the transfer to complete.

23.4. Troubleshooting a line power system

This section describes to how to troubleshoot line power system alarms, overload, and transient events.

23.4.1. Resolving line power system alarms

Some of the alarms from the line power system are generated by the line power system modules. These alarms are *Input Voltage High/Low Shutdown*, *High Temperature Shutdown*, *Temperature Warning*, *Module Connection Error*, and any alarm with *Channel* in its name. This section describes how to identify the module causing the alarm.

1. When one of the line power systems previously mentioned is active, go to **Systems > Line Power System > Layout**.
2. On the **Layout** page look for a module outlined in red, or a channel with the red exclamation mark icon that signifies a channel alert. The table shows the physical location of the module to help find it, should it need to be replaced.
3. Select the channel with the alert icon. If the module is outlined in red, but no channels appears to be in alert, select any channel.
4. The channel details display in another table.
5. Select the link to show the module details.
6. In the **Alerts** table, sort the **Value** column to show all the active alerts at the top. This identifies all the alerts that are active on the module. Use the help text for the alerts to decide on the corrective action.

23.4.2. Fan tray alarms

The line power system may be installed with one or more optional fan trays. The fan tray is a CAN connected ADIO device that has a **Fan Fail** alarm associated with it. This section describes how to identify the module causing the alarm.

1. Go to **Alarms > Active Alarms**.
2. In the **Active Alarms** table, find the **Fan Fail Alarm** and note the name of the fan tray that is responsible. This confirms the alarm is caused by the fan tray and not some other device.
3. Look for the physical fan tray with the red LED. Repair or replace as required.

23.4.3. Line power system overload

If the line power system is overloaded, one or more modules will start flashing the front panel LEDs yellow. Eventually the input voltage low alarm may be activated if it is configured and enabled.

If this occurs it may be necessary to add more capacity at the input to the line power system, reduce the power drawn by the remote load or add more line power modules.

23.4.4. Line power system transient events

Depending on circumstances a remote load may experience a brown-out or momentary loss of power. This is sometimes caused by a channel that has had a transient low output voltage, ground fault or over-voltage protection shutdown. Since these transients occur too quickly to trigger an alarm they are instead logged to the module alert log. After a suspected transient event:

1. Go to **Logs > Events & Alerts** and view the **Module Alerts** table.
2. In the **Search** field, type “transient”. The table now shows only the transient events that have occurred. If the table is empty then no transients were detected.
3. Each entry for a transient event shows the serial number of the module responsible. Note the serial number.
4. Go to **Systems > Line Power System > Inventory > Line Power Modules** and type the serial number of the module in the search field. All other modules should now be filtered out leaving only the module of interest.
5. Use the **Locate** button to visually identify the module in the rack.
6. Depending on the type of transient event detected, it may be necessary to unplug and insert the module to ensure it is fully seated, replace the module or check and fix any channel connections.

23.4.5. Line power channels file import errors

This section describes errors that may be presented when importing a line power channels file and how to potentially fix the related error.

Error Message on Import: No line powering modules found assigned to the system therefore the selected CSV file was not imported. Please check that there are line power modules present and assigned to the system and try again.

Solution:

1. Check that there are line power modules acquired. To see acquired modules, on the controller, go to the **Modules** page and check the **CAN Modules** table.
2. If modules are acquired in the **CAN Modules** table, go to **Systems > Line Power System > Line Power Modules > Modules Available for Assignment > Assign All**.
3. If modules are acquired but the table in (2) does not display anything then verify that the correct line power system is created.

Error Message on Import: Line powering modules found to be communications lost therefore the selected CSV file was not imported. Check that the modules assigned to the system are communications normal. Please check the eventlog for the modules that were found to be communications lost.

Table 23-2 Example of an event entry for error (time column not displayed):

Source	Name	Value
Import Line Power Channels	Module is Comms Lost	396000014/0114

Solution:

1. Check that the module that is indicated in the Value column is plugged into the shelf.
2. Verify the CAN bus is enabled for whichever CAN bus the module is communicating on. To do this, go to **Controller > Communication > CAN**. Select the **GO TO** button in the CAN table to view additional information and edit configuration.
3. If both (1) and (2) are enabled, then verify the physical CAN wiring to the shelf is working.

Error Message on Import: Found errors in imported CSV file. CSV file was not imported. Please check the eventlog to correct errors and then try again.

The source of the error in the Events table for a Line Power Channels Import will always be: Import Line Power Channels.

Examples of possible Name and Value entries from the Events table are displayed in the following table: Troubleshooting Errors in Line Power Channels CSV File.

Table 23-3 Troubleshooting errors in a line power channels CSV file

Name	Value	Analysis of value	Solution
No module found for channel	CSV Row #: 98; LP Ch: 3-1.1; Load: TestLoad	<p>The error was caught in the CSV file on row 98. A module was not found on 3-1.1 which corresponds to Shelf-Slot.Channel. For the Load to be created which was named TestLoad.</p> <p><i>Note: The Load portion may be truncated if the load name exceeded available space.</i></p>	<ol style="list-style-type: none"> 1. Check that a module is inserted for Shelf 3 in Slot 1 of the Line Power System. 2. Remove the Load Name entry if there was no load intended to be created for this channel.

Table 23-3 Troubleshooting errors in a line power channels CSV file (continued)

Name	Value	Analysis of value	Solution
Invalid Channel Entry	CSV Row #: 2; Value: 5; LP Ch: 1-1.5	The error was caught in the CSV file on row 2. A channel entry value was found to be 5 for 1-1.5 which corresponds to the Shelf-Slot.Channel.	A line power module only has up to 4 channels. Change the channel entry value from a 5 to a value between 1 to 4.
Invalid Slot Entry	CSV Row #: 3; Value: @; LP Ch: 1-@.2	The error was caught in the CSV file on row 3. A slot entry value was found to be @ for 1-@.5 which corresponds to the Shelf-Slot.Channel.	A line power shelf can have up to 12 slots. There is an invalid character (@) for the slot. Change the value to be between 1 to 12.
Invalid Shelf Entry	CSV Row #: 5; Value: 1.3; LP Ch: 1.3-1.4	The error was caught in the CSV file on row 5. A shelf entry value was found to be 1.3 for 1.3-1.4 which corresponds to the Shelf-Slot.Channel.	A line power system can have up to 9 shelves. The shelf entry was a decimal value. Change the shelf entry value to be between 1 to 9.

24. Cordex® CXC HP controller reference guide

The following section is a reference guide for the controller software.

24.1. CAN modules

This table provides information on support for CAN modules.

Table 24-1 Support for CAN modules

Category	Device name	Controller software support
ADIO	Cordex® CXC HP L-ADIO	Version 2.00 and later
ADIO	Cordex® CXC HP 6i-ADIO	Version 2.00 and later
ADIO	Shunt multiplexer (MUX)	Version 2.00 and later ¹
ADIO	I/M1 ADIO	Version 2.20 and later
ADIO	PSU ADIO	Version 2.20 and later
ADIO	Cordex® CXC HP HV-ADIO	Version 3.00 and later
ADIO	8R8D ADIO	Version 3.10v
ADIO	4R8D ADIO	Not Planned ²
ADIO	12V BCM	Not Planned
ADIO	2V BCM	Not Planned
ADIO	BDFB VI Meter	Version 3.10 and later
ADIO	LPS Fan Tray ADIO	Version 3.20 and later
ADIO	Smart E2	Version 4.00 and later
Rectifier	Cordex® HP 250W 12Vdc	Version 2.10 and later
Rectifier	Cordex® 400W 24Vdc	Version 2.00 and later
Rectifier	Cordex® 3.1kW 24Vdc	Version 2.00 and later
Rectifier	Cordex® HP 300W 48Vdc	TBD
Rectifier	Cordex® 650W 48Vdc	Version 2.00 and later
Rectifier	Cordex® 1kW 48Vdc	Version 2.00 and later
Rectifier	Cordex® HP 1.2kW 48Vdc	Version 2.00 and later
Rectifier	Cordex® 1.8kW 48Vdc	Version 2.00 and later

1. The MUX can be monitored by the controller but it cannot be calibrated by the controller.
2. The 4R8D ADIO peripheral is not officially supported. If you connect one to the controller, it will show up as an 8D8R ADIO. All eight digital inputs will function correctly. The first four relays will function correctly and are mapped to the four physical relays on the 4R8D ADIO peripheral.

Table 24-1 Support for CAN modules (continued)

Category	Device name	Controller software support
Rectifier	Cordex® HP 2.0kW 48Vdc	Version 2.00 and later
Rectifier	Cordex® HP 2.4kW 48Vdc	Version 2.00 and later
Rectifier	Cordex® HP 3.0kW 48Vdc (Hardware Revision 1)	Version 6.00 and later
Rectifier	Cordex® HP 3.0kW 48Vdc (Hardware Revision 2)	Version 7.20 and later
Rectifier	Cordex® 3.6kW 48Vdc	Version 2.00 and later
Rectifier	Cordex® HP 4.0kW 48Vdc	Version 2.00 and later
Rectifier	Cordex® HP 4.6kW 48Vdc	Version 5.00 and later
Rectifier	Cordex® HP 12kW 48Vdc (Hardware Revision 1)	Version 2.11 and later
Rectifier	Cordex® HP 12kW 48Vdc (Hardware Revision 2)	Version 6.00 and later
Rectifier	Cordex® 3.3kW 65Vdc	Not Planned
Rectifier	Cordex® 1.1kW 125Vdc	Version 3.00 and later
Rectifier	Cordex® 1.1kW 220Vdc	Version 3.00 and later
Rectifier	Cordex® 4.4kW 125Vdc	Version 3.00 and later
Rectifier	Cordex® 4.4kW 220Vdc	Version 3.00 and later
Converter	Cordex® CXDF 2kW 24-48Vdc	Version 2.01 and later
Converter	Cordex® CXDF 2kW 48-24Vdc	Version 2.01 and later
Sub-controller	T2S	Version 3.00 and later
Inverter	AIM 1500	TBD
Inverter	AIM 2500	Version 3.00 and later
Inverter	TUS	Version 3.10 and later
Line Powering	Cordex® HP LPS36	Version 3.20 and later
Line Powering	Cordex® HP eLimiter+ Distribution System	Version 3.20 and later
FXM	FXM ADIO	Version 6.00 and later
ADIO	XMBS Smart Bypass G1	Version 6.20 and later
ADIO	FlexAir®	Version 7.00 and later
ADIO	XMBS Smart Bypass G2	Version 7.01 and later

Table 24-1 Support for CAN modules (continued)

Category	Device name	Controller software support
Converter	Cordex® CXPS-HSS Hyperboost Converter System	Version 8.00
ADIO	Matrix C16™ High Density Connectorized DC Distribution Breaker Panel	Version 8.00

24.2. Communication ports

There are three sets of ports that are used for controller communication:

- Two Ethernet ports, commonly referred to as the front and rear Ethernet ports.
- Two USB ports, commonly referred to as the front and rear USB ports.
- Two CAN ports, commonly referred to as CAN1 and CAN2.

24.2.1. Ethernet ports

The Ethernet ports support a standard RJ45 connection and can run at 10BASE-T or 100BASE-T speeds with auto MDI-X detection (Medium Dependent Interface crossover detection) to eliminate the need for cross-over cables.

The Ethernet ports support the IPv4 and IPv6 protocols. The IPv4 protocol supports both static IP and DHCP configuration. The IPv6 protocol will configure a link-local address automatically. Addresses with other scopes are configured by Router Advertisements (RA). Both the LCD and web interface will display the full list of IPv6 addresses that have been configured for each port.

You can also use IPv6 addresses for outgoing messages including email servers and SNMP destinations. SNTP does not support IPv6 at this time.

The controller does not register itself with DNS servers nor can it be configured to join a domain or work group. However, the controller is capable of using a DNS server to resolve domain names if the gateway is set up to allow that.



Notice: While there are two Ethernet ports available on the controller, it is recommended that they are not both connected to the same network. There is a concern that network management systems and higher level control systems will see the controller as two devices and get duplicate notifications (SNMP traps for example) for a single device.

24.2.2. USB ports

The USB ports support a standard, full-size USB host connection.

Only USB mass storage devices that have been formatted with a FAT32 file system are fully supported for use in the USB ports. USB drives with the NTFS file system will not work.

USB ports can be disabled to provide enhanced anti-tampering above and beyond the normal local physical security of a typical installation. When disabled, the no USB device will function when plugged in and should this be required, go to **Controller > Settings > User Interface** and in the **User Interface** table you can disable and enable USB ports. To successfully disable the ports, first ensure that there are no USB devices plugged in. Failure to do so may prevent a port from being disabled, as it is in use; a reset or power cycle may be required before another attempt to disable will be successful. A disabled USB port should provide no power to the plugged in device. If the device has an LED on it, this may be used to determine if the port is actually disabled.

24.2.3. CAN ports

Introduction to CAN for the Cordex® CXC HP controller

CAN is used by the controller to discover, collect data from, control, and configure the power modules and I/O (ADIO) modules in the power system. The controller has two up to CAN buses, each of which can control up to 127 power and ADIO modules.

What is a CAN bus?

A controller area network (CAN) refers to a network of devices that communicate using the CAN serial protocol to support distributed real-time control.

How do CAN bus modules communicate?

A CAN bus uses two dedicated wires for communication called CAN high and CAN low. When the CAN bus is idle, both lines carry 2.5 volts. When data bits are being transmitted, the CAN high line goes to 3.75 volts and the CAN low drops to 1.25 volts, thereby generating a 2.5 volts difference between the lines. Since communication relies on a voltage difference between the two bus lines, the CAN bus is insensitive to inductive spikes, electrical fields or other noise. This makes CAN bus a reliable choice for networked communications in electrically noisy environments.

Figure 24-1 CAN differential signaling

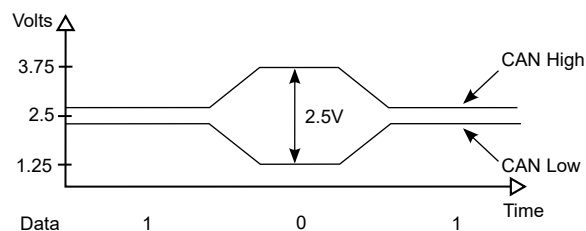

CAN network topology

A CAN network uses a twisted pair cable to transmit the differential signals, terminated at both ends with 120 ohm resistors.

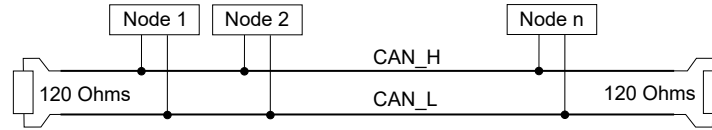
Figure 24-2 CAN network topology

What is CAN power?

CAN power can be supplied through CAN bus. Optionally a power supply for the CAN bus modules can be arranged separately. The power supply wiring can be either totally separate from the CAN bus lines using two, two-wire cables or it can be combined with the CAN bus lines into a single four-wire cable. CAN bus cabling is available from multiple vendors.

How are Alpha® CAN cables wired?

The Alpha® CAN connector is a 6P6C offset latch modular connector. The male connectors are called plugs and the female connectors are called jacks. You may also hear these connectors referred to by their registered jack (RJ) equivalent: RJ11, RJ14, and RJ25 are all physically compatible with 6P6C modular connectors. The following figure shows the CAN pinout for a 6P6C offset latch modular plug. Pins 1 and 6 are used for CAN power while pins 2 and 4 are used for CAN signaling.

Figure 24-3 Alpha® CAN connector

Are there distance limitations?

The electrical characteristics of a typical CAN bus cable restrict the cable length. We recommend having no more than one long CAN cable on a CAN bus and to restrict the length of that long cable to less than 100 meters (328 feet).

Is the number of nodes (modules) limited?

CAN allows up to 127 modules per bus.

Where can I get more information about CAN?

CAN is specified by the International Standards Organization (ISO) standard ISO 11898.

24.3. Default system values and ranges

The following section provides tables of the default values and ranges for supported systems.

24.3.1. 12 volt system default values and ranges

This table provides the default values and ranges for a 12 volt system.

Table 24-2 12 volt system default values and ranges

Setting name	Default	Minimum	Maximum
Allowed Voltage Range	N/A	10.5	15
Float Voltage	13.5	11.875	14.55
Equalize Voltage	13.75	12.45	15.05
Boost Voltage	13.75	12.45	15.05
Rectifier - Minimum Test Voltage	11	N/A	N/A
Safe Voltage	12.85	11.5	14
Over Voltage Protection	14.25	12.125	15.75
Absorption Voltage	13.75	12.45	14.75
Absorption Arming Voltage	12	10.5	13.25
Temp Comp Max Voltage	13.875	N/A	14.5
Temp Comp Min Voltage	13.125	11.875	N/A
Battery String Number of Cells	6	1	200
Temp Comp Voltage Warning	0.25	0	0.25
Battery Test Termination Voltage	11.125	11.125	15
Output Voltage High Alarm	13.875	10.5	15
Output Voltage Very High Alarm	14.125	10.5	15
Output Voltage Low Alarm	12	10.5	15
Output Voltage Very Low Alarm	11.625	9	15

24.3.2. 24 volt system default values and ranges

This table provides the default values and ranges for a 24 volt system.

Table 24-3 24 volt system default values and ranges

Setting name	Default	Minimum	Maximum
Allowed Voltage Range	N/A	21	30
Float Voltage	27	23.75	29.1
Equalize Voltage	27.5	24.9	30.1
Boost Voltage	27.5	24.9	30.1
Rectifier - Minimum Test Voltage	22	N/A	N/A
Safe Voltage	25.7	23	28

Table 24-3 24 volt system default values and ranges (continued)

Setting name	Default	Minimum	Maximum
Over Voltage Protection	28.5	24.25	31.5
Absorption Voltage	27.5	24.9	29.5
Absorption Arming Voltage	24	21	26.5
Temp Comp Max Voltage	27.75	N/A	29
Temp Comp Min Voltage	26.25	23.75	N/A
Battery String Number of Cells	12	1	200
Temp Comp Voltage Warning	0.5	0	0.5
Battery Test Termination Voltage	22.25	22.25	26
Output Voltage High Alarm	27.75	21	30
Output Voltage Very High Alarm	28.25	21	30
Output Voltage Low Alarm	24	21	30
Output Voltage Very Low Alarm	23.25	18	30

24.3.3. 48 volt system default values and ranges

This table provides the default values and ranges for a 48 volt system.

Table 24-4 48 volt system default values and ranges

Setting name	Default	Minimum	Maximum
Allowed Voltage Range	N/A	42	60
Float Voltage	54	47.5	58.2
Equalize Voltage	55	49.8	60.2
Boost Voltage	55	49.8	60.2
Rectifier - Minimum Test Voltage	44	N/A	N/A
Safe Voltage	51.4	46	56
Over Voltage Protection	57	48.5	63
Absorption Voltage	55	49.8	59
Absorption Arming Voltage	48	42	53
Temp Comp Max Voltage	55.5	N/A	58
Temp Comp Min Voltage	52.5	47.5	N/A
Battery String Number of Cells	24	1	200

Table 24-4 48 volt system default values and ranges (continued)

Setting name	Default	Minimum	Maximum
Temp Comp Voltage Warning	1	0	1
Battery Test Termination Voltage	44.5	44.5	52
Output Voltage High Alarm	55.5	42	60
Output Voltage Very High Alarm	56.5	42	60
Output Voltage Low Alarm	48	42	60
Output Voltage Very Low Alarm	46.5	36	60

24.3.4. 125 volt system default values and ranges

This table provides the default values and ranges for a 125 volt system.

Table 24-5 125 volt system default values and ranges

Setting name	Default	Minimum	Maximum
Allowed Voltage Range	N/A	90	160
Float Voltage	140.625	90	160
Equalize Voltage	143.23	90	160
Boost Voltage	143.23	90	160
Rectifier - Minimum Test Voltage	114.58	90	160
Safe Voltage	133.85	90	160
Over Voltage Protection	151.04	90	160
Absorption Voltage	143.23	90	160
Absorption Arming Voltage	125	90	160
Temp Comp Max Voltage	144.53	N/A	160
Temp Comp Min Voltage	136.72	90	N/A
Battery String Number of Cells	63	1	200
Temp Comp Voltage Warning	2.6	0	2.6
Battery Test Termination Voltage	115.89	90	160
Output Voltage High Alarm	144.53	90	160
Output Voltage Very High Alarm	147.14	90	160
Output Voltage Low Alarm	125	90	160
Output Voltage Very Low Alarm	121.09	93.75	160

24.3.5. 220 volt system default values and ranges

This table provides the default values and ranges for a 220 volt system.

Table 24-6 220 volt system default values and ranges

Setting name	Default	Minimum	Maximum
Allowed Voltage Range	N/A	180	320
Float Voltage	247.5	180	320
Equalize Voltage	252.08	180	320
Boost Voltage	252.08	180	320
Rectifier - Minimum Test Voltage	201.67	180	320
Safe Voltage	235.58	180	320
Over Voltage Protection	265.83	180	320
Absorption Voltage	252.08	180	320
Absorption Arming Voltage	220	180	320
Temp Comp Max Voltage	254.38	N/A	320
Temp Comp Min Voltage	240.63	180	N/A
Battery String Number of Cells	110	1	200
Temp Comp Voltage Warning	4.58	0	4.58
Battery Test Termination Voltage	203.96	180	320
Output Voltage High Alarm	254.38	180	320
Output Voltage Very High Alarm	258.96	180	320
Output Voltage Low Alarm	220	180	320
Output Voltage Very Low Alarm	213.13	165	320



Alpha Technologies Ltd. | 7700 Riverfront Gate, Burnaby, BC V5J 5M4 Canada
Toll Free North America: +1 800-667-8743 | Outside North America +1 604-436-5547 | Technical Support +1 888-462-7487
For more information visit our website at: www.enersys.com

© 2023 Alpha Technologies Ltd., an EnerSys company. All Rights Reserved. Trademarks and logos are the property of EnerSys and its affiliates.
Subject to revisions without prior notice. E. & O.E.

0350058-J0 REV AL (01/2023)